

CHIEF'S SHOP PLAN OF THE WEEK



SIMPLE WOODWORKING: BEGINNER SIDE TABLE



WHAT YOU'LL NEED



LUMBER

2 - 1 x 2 x 6
 1 - 1 x 4 x 8
 4 - 2 x 2 x 3
 1 - 3/4 x 2- x 2-foot sheet of plywood
 scrap 1/2" plywood (availability will vary)

HARDWARE/SUPPLIES

1 1/4" pocket hole screws
 wood glue
 paint/stain

TOOLS

miter saw
 sander
 drill/driver
 Kreg Pocket Hole Jig
 clamps
 square

ABOUT THESE PLANS

On this first page you will see above the project complete. On the [last page](#) you'll find the finished outer dimensions. Be sure to read ALL of the project steps before you start.

To the right is a list of the Lumber, Hardware/Supplies, and Tools you will need to complete this project. A measuring tape and pencil are not included because that should be pretty standard and self explanatory.

Below What You'll Need is the Parts list. This also is included on the [Cutting Diagram](#) page, which is the next to last page of this plan document. Also on the [Cutting Diagram](#) page is an estimate of the cost of the lumber. This estimate doesn't include any other supplies and does not factor in sales tax.

Throughout these plans you'll find the icons below:



LAYOUT

This indicates a diagram detailing the dimensions of a project part and/or the placement for pocket holes, screws, nails, etc.



NOTE

Notes are the instructions for a particular step/section of the project.



TAKE CARE!

This indicates when to pay close attention to the diagrams, take precautions for safety, etc.



MORE PLANS

Want more Chief's Shop plans? Visit chiefs-shop.com and look through the Plans section. Be sure to "Like" Chief's Shop on facebook by heading over to facebook.com/ChiefsShop.

PARTS

Legs (4) - 1 1/2 x 1 1/2 x 26
 End Rails (2) - 3/4 x 3 1/2 x 18
 Side Rails (2) - 3/4 x 3 1/2 x 18
 Top (1) - 3/4 x 24 x 24
 Short Trim (2) - 3/4 x 1 1/2 x 24
 Long Trim (2) - 3/4 x 1 1/2 x 25 1/2

All parts are listed in actual dimensions. Refer to the Cutting Diagram on the last page of this plan as a guide for determining the specific board from which to cut the parts.

LAYOUT

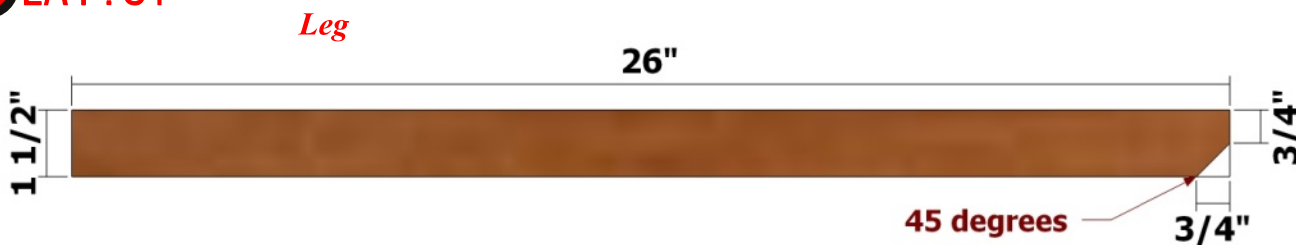

NOTE

Use the layout as a guide for measuring, marking, and cutting the **Legs**. **Make four.**

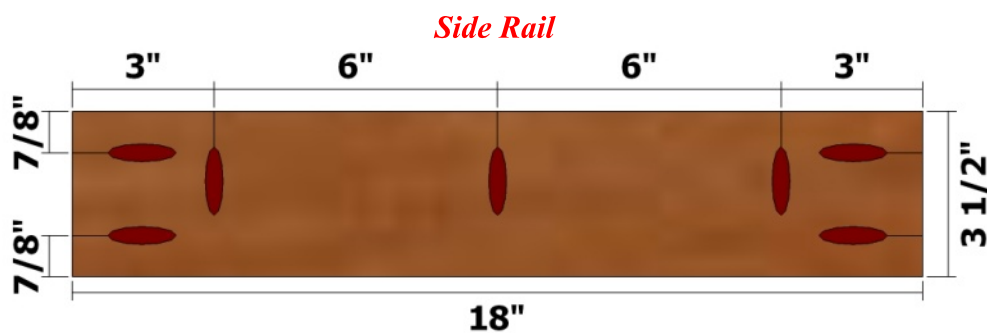
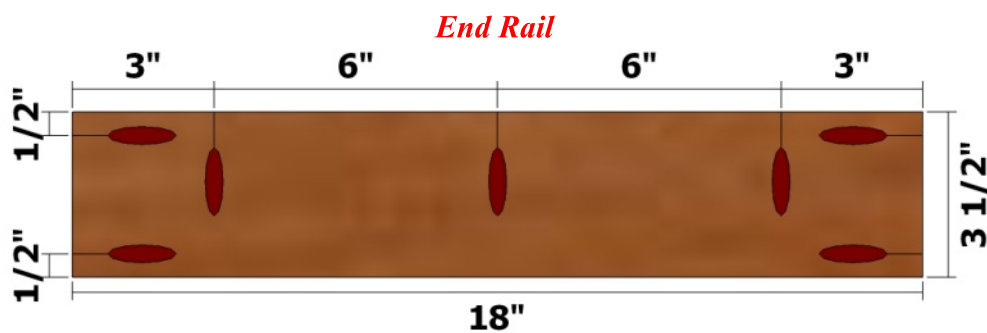

NOTE

Use the layouts as guides for measuring, marking, cutting, and drilling pocket holes in the **End Rails** and **Side Rails**. **Be sure to set your pocket hole jig and drill bit for 3/4-inch stock.** **Make two of each.**

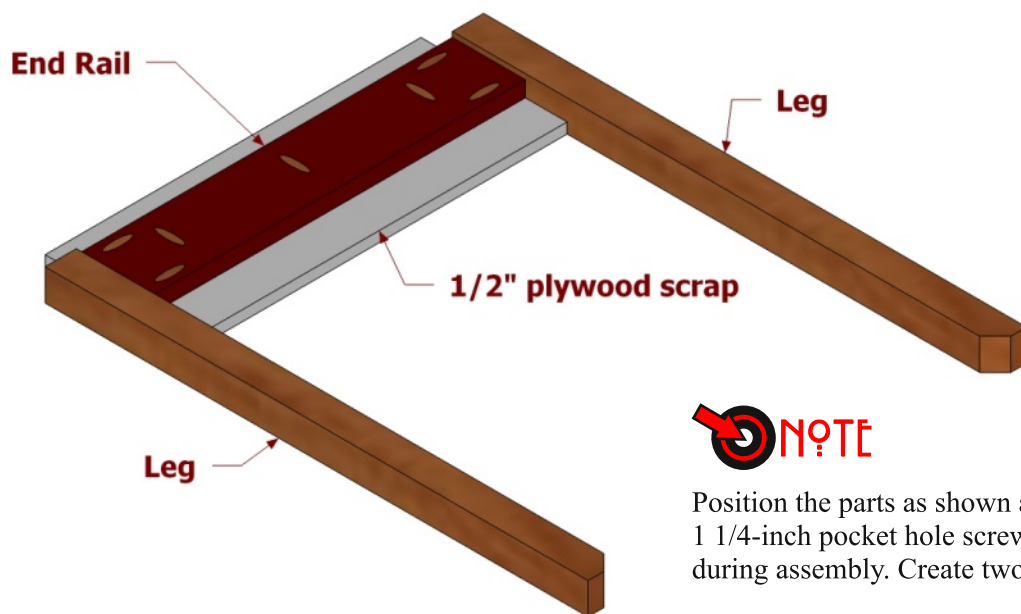

 **NOTE**

Position the parts as shown and attach using glue and 1 1/4-inch pocket hole screws. Clamp the parts in place during assembly. Create two assemblies.

 **NOTE**

Position the parts as shown and attach using glue and 1 1/4-inch pocket hole screws. Clamp the parts in place during assembly.

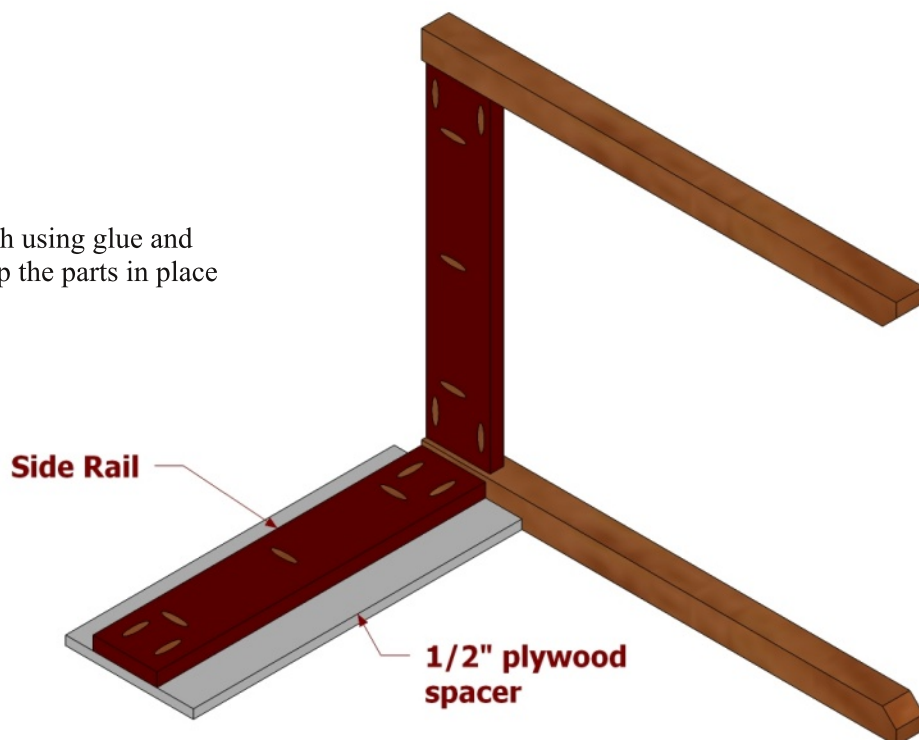

 NOTE

Position the parts as shown and attach using glue and 1 1/4-inch pocket hole screws. Clamp the parts in place during assembly.

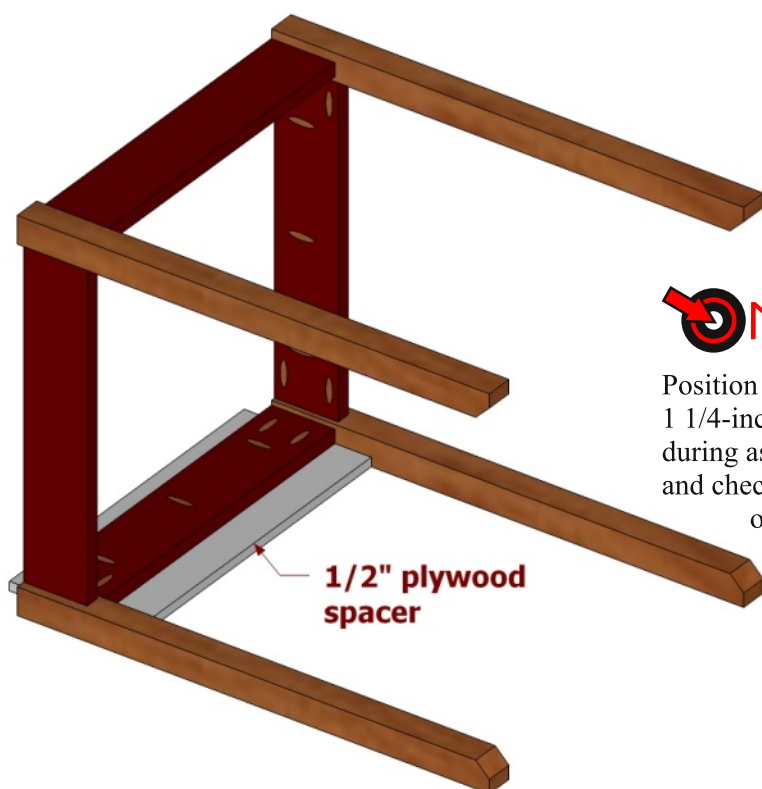
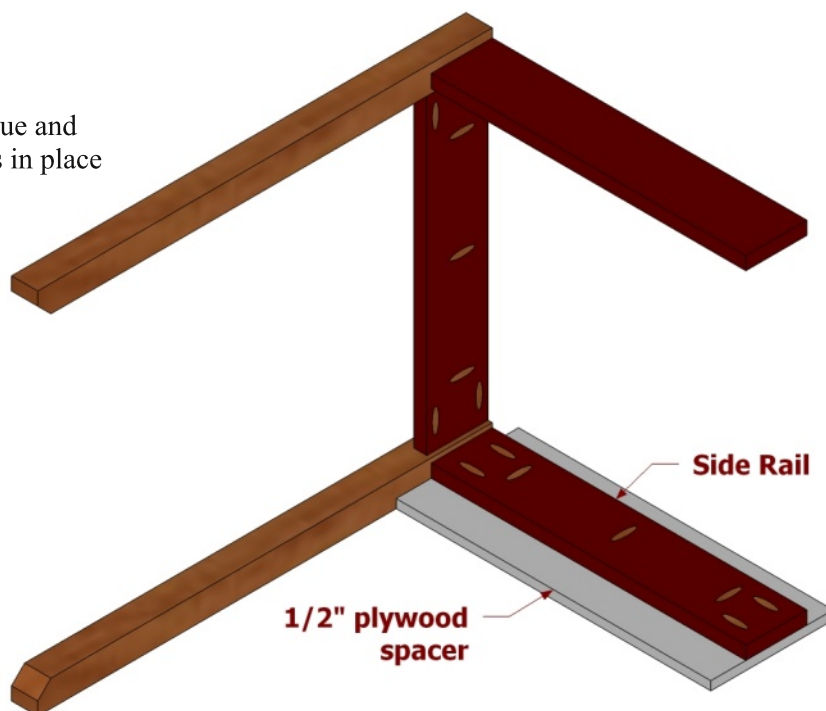

 NOTE

Position the parts as shown and attach using glue and 1 1/4-inch pocket hole screws. Clamp the parts in place during assembly. Place the assembly with the **Legs** down and check for square. Adjust as needed and clamp in place or use temporary bracing until the glue sets. For a video on *How To Check For Square*, visit chiefs-shop.com/html/videos.html.

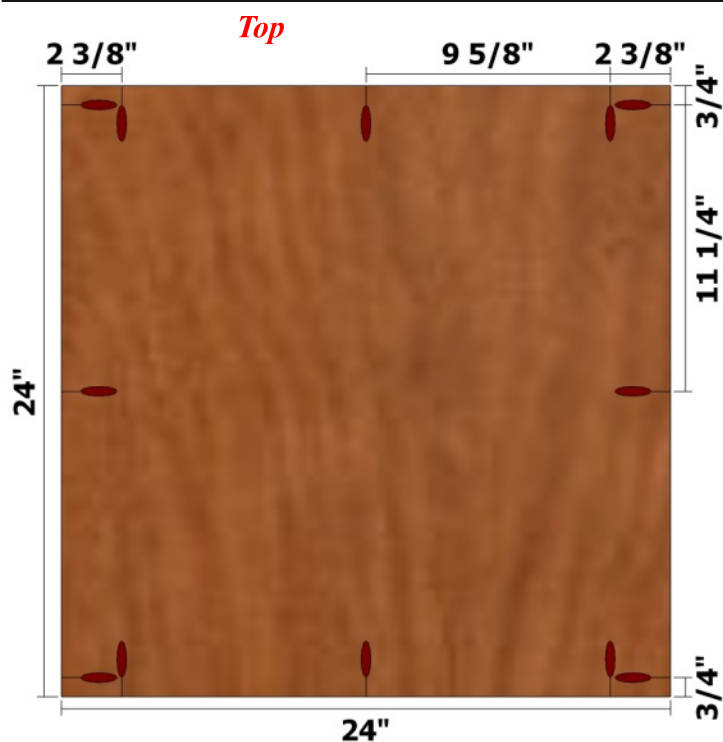

LAYOUT

NOTE

Use the layout as a guide for measuring, marking, cutting, and drilling pocket holes in the **Top**.
Be sure to set your pocket hole jig and drill bit for 3/4-inch stock.

NOTE

Position the parts as shown and attach using glue and 1 1/4-inch pocket hole screws. Be sure to attach the **Short Trim** FIRST, then attach the **Long Trim**.

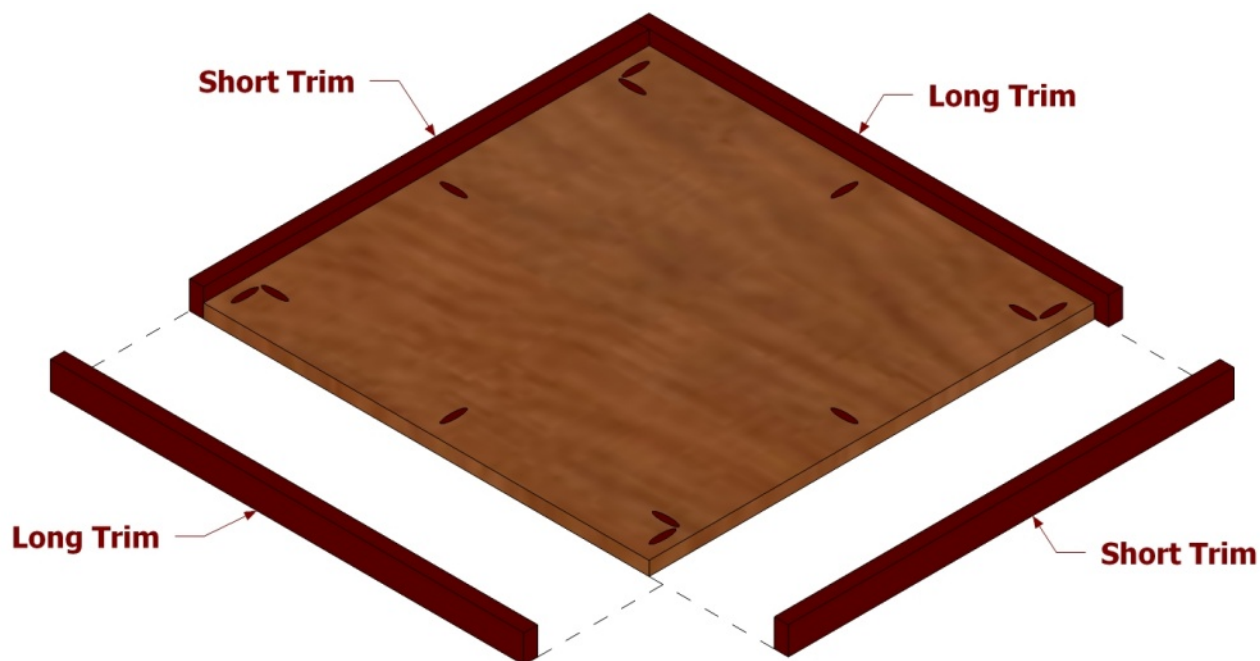

NOTE

Cut eight spacers from the left over 1 x 2 from which you cut the **Trim**. Position them in the corners as shown, then place the **Rail/Leg Assembly** as shown and attach using glue and 1 1/4-inch pocket hole screws. Remove the spacers immediately.

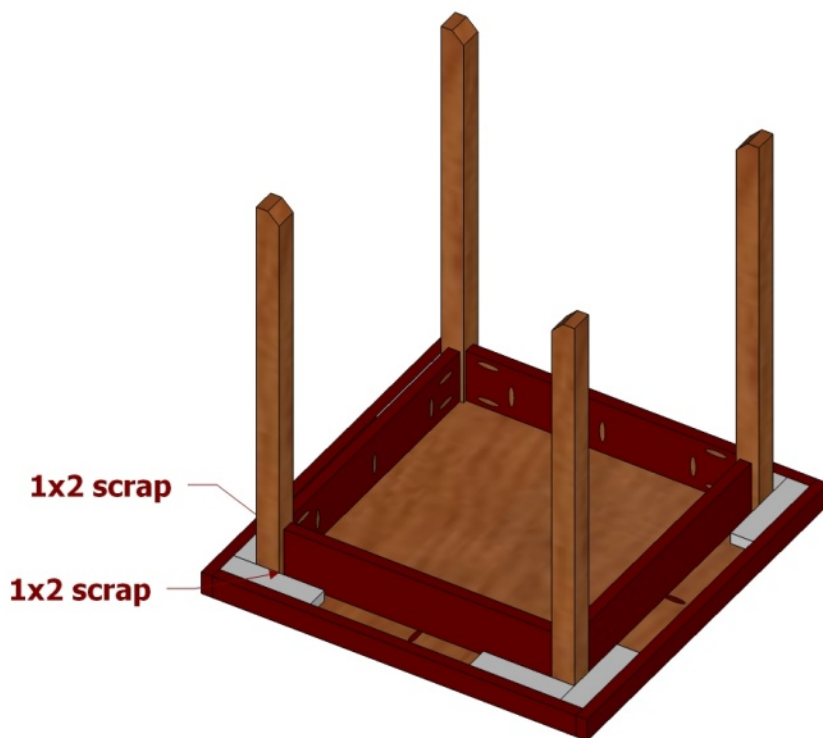
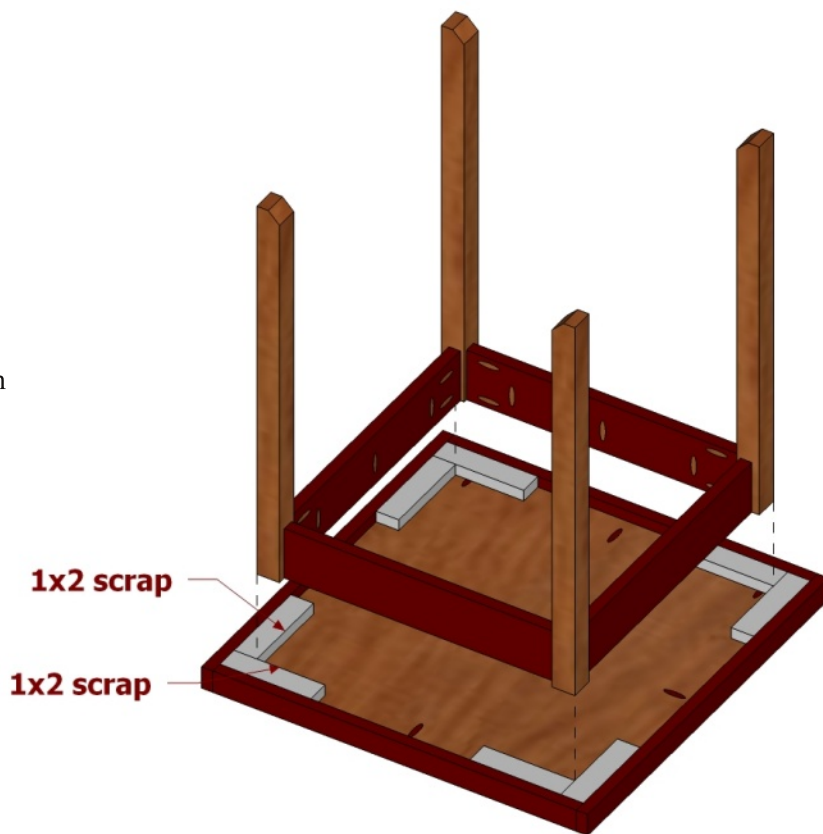

 **CUTTING DIAGRAM**

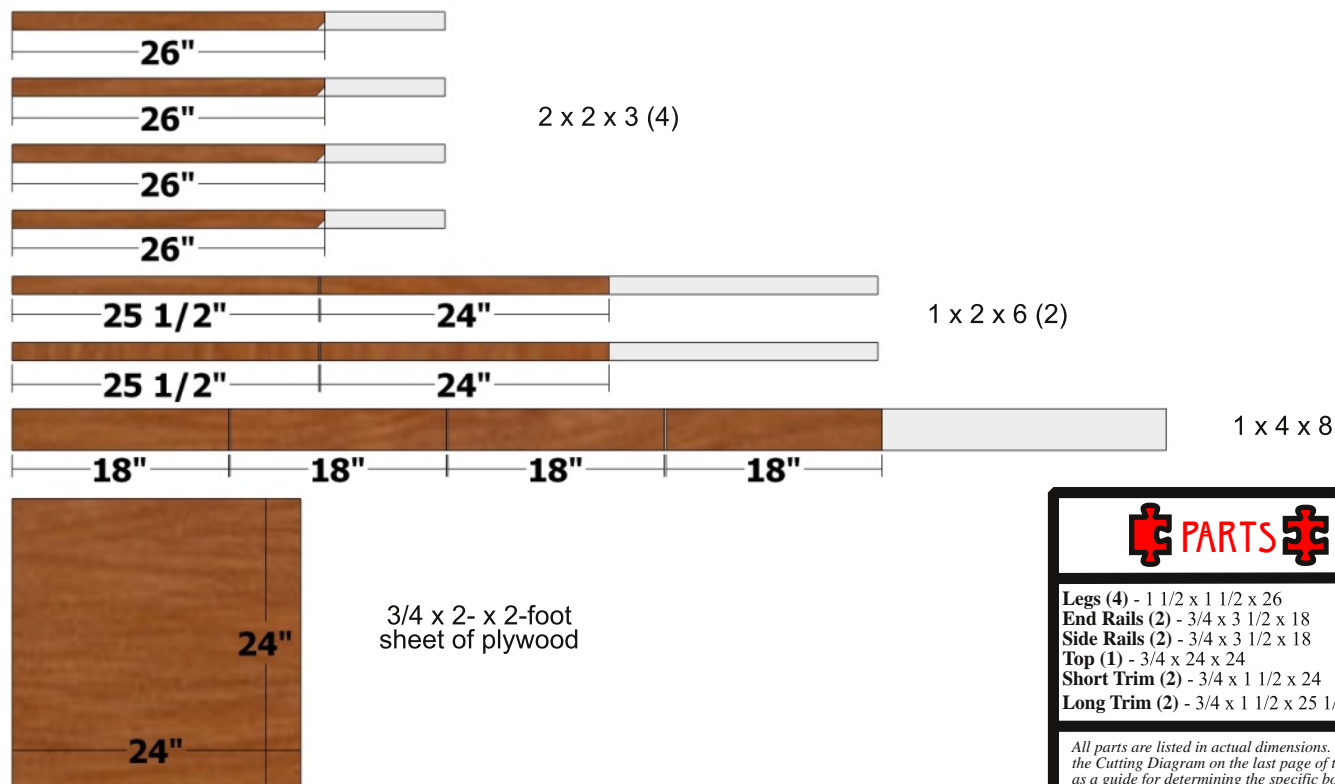

PARTS

Legs (4) - 1 1/2 x 1 1/2 x 26
End Rails (2) - 3/4 x 3 1/2 x 18
Side Rails (2) - 3/4 x 3 1/2 x 18
Top (1) - 3/4 x 24 x 24
Short Trim (2) - 3/4 x 1 1/2 x 24
Long Trim (2) - 3/4 x 1 1/2 x 25 1/2

All parts are listed in actual dimensions. Refer to the Cutting Diagram on the last page of this plan as a guide for determining the specific board from which to cut the parts.

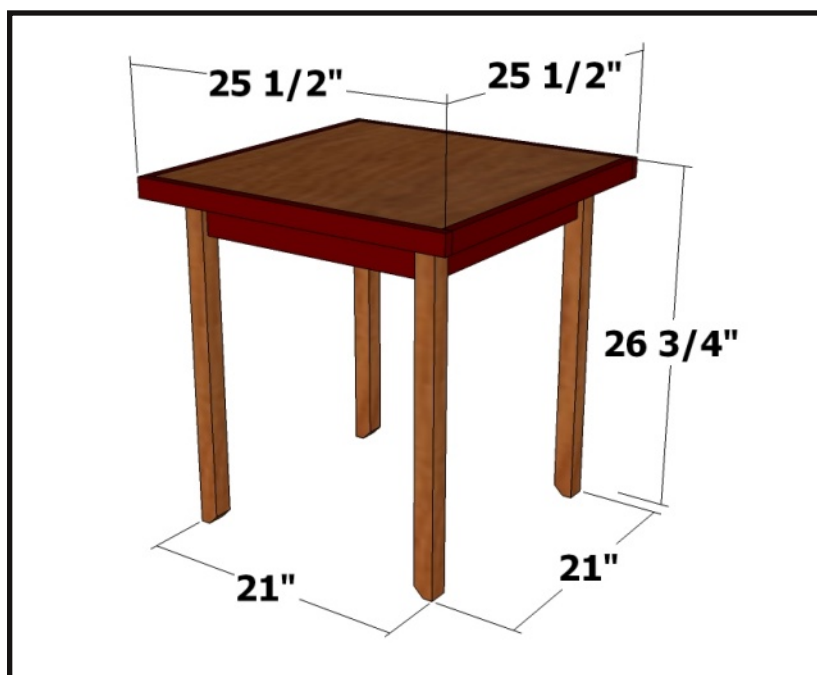

 **TAKE CARE!**

Follow ALL SAFETY GUIDELINES AND RECOMMENDATIONS provided by the manufacturers of your tools, and any chemicals such as glue and finishes you use in this project. YOU are responsible for your safety, so use common sense when working in the shop!