

CELEBRATING

40
YEARS

WOODSHOP

SHAPING THE SUCCESSFUL SHOP™

www.woodshopnews.com

APRIL 2026

NEWS®

Catering to all

Burkard Custom Cabinets grows through referrals, technology investment

Cabinet hardware that gets the details right

Today's joinery embraces engineered solutions

The evolution of wood protection

NEW TOOLS

- Grizzly benchtop CNC
- Metabo HPT crown stapler
- Oliver 6" and 8" jointers
- Oneida XT14 dust extractor

\$3.95 (Canada, \$5.95)



MERIVOBX

MERIVOBX adapts to a wide range of applications, lifestyles and spaces. Its platform design covers multiple configurations, reducing complexity, speeding up installs and delivering consistent, high-quality drawer performance.



Learn more about MERIVOBX at blum.com



ANDERSON AMERICA INC.
Anderson Group

**WHEN YOU'RE
SERIOUS ABOUT
YOUR BUSINESS,
IT DESERVES A
SERIOUS MACHINE**

Anderson America has been providing American businesses with the best value in CNC machine tools since 1991. We continue to satisfy the most demanding US customers with over 4500 installations in North America. We are a proven brand, with long and proven track record for delivering premium capabilities at a competitive price.

**PUT US TO
THE TEST.**

Find out why so many of the Countries Premier Manufacturers choose Anderson for their production needs. When you get serious, you upgrade to Anderson.

**YOU'RE NOT A START UP COMPANY ANYMORE.
SO WHY CONSIDER A STARTUP MODEL CNC?**



STRATOS PRO FULL AUTO



EXXACT PLUS DUO TC2



MAXXIS 1631 IP



MASS-1540 IP

CONTACT US

**INFO@ANDERSONAMERICA.COM
ANDERSONAMERICA.COM**

SALES: 704-522-1823

MARTIN

Woodworking Machines



Woody 1100 Giant 1350

The Giant 1350 is a fixed-height machine featuring customizable units for versatile sanding applications. The Woody 1100 offers similar versatility in a compact design.

Discover our range of machines and Accessoires for your workshop.



www.martin-usa.com

info@martin-usa.com, 8715 Sidney Circle, Suite 100 Charlotte, NC 2829, 704-921-0360

Table of Contents



Jennifer Hicks (top, cover)

30

Features

- 20 THE DEVIL IS IN THE DETAILS:**
Cabinet hardware innovations that enhance function, durability, accessibility, and customer satisfaction.
- 30 CATERING TO ALL:**
Burkard Custom Cabinets grows through referrals, technology investment.
- 35 BEYOND DOVETAILS:**
Today's joinery embraces engineered solutions.
- 42 THE EVOLUTION OF WOOD PROTECTION:**
From solvent-heavy lacquers to water-based UV systems, finishing technology adapts to stricter regulations and changing customer demands.

News Desk

- | | |
|---|---|
| <p>8 Builders' show fuels homebuilding momentum.</p> <p>10 C.R. Onsrud opens expanded facility for annual Demo Day.</p> | <p>12 WOOD MARKETS:
Butternut supply keeps dwindling.</p> <p>13 Wood machinery leaders to gather in Puerto Rico ahead of IWF.</p> |
|---|---|

Woodshop News, (ISSN 0894-5403, U.S.P.S. 000-966), Vol. XXXX, NO. 5, is published monthly by Active Interest Media, Holdco, Inc. The known office of publication is 2143 Grand Ave., Des Moines, IA 50312. Periodicals postage paid at 2143 Grand Ave., Des Moines, IA 50318-9652, and additional mailing offices. \$21.95 for one year; \$35.95 for two years (Canadian subscribers add \$12 per year for postage; U.S. funds, foreign subscribers add \$14 per year for postage; U.S. funds). Postmaster: Send address changes to WOODSHOP NEWS, PO Box 37274, Boone, IA 50037-0274. Printed in the U.S.A. POSTMASTER: Send all UAA to CFS. (See DMM 507.1.5.2); NON-POSTAL AND MILITARY FACILITIES: Woodshop News, Circulation Department, PO Box 37217, Boone, IA 50037.

PREMIUM SHARPENING SERVICES

For all types of woodworking tooling including:

- Saw Blades
- Router Bits
- Shaper Cutters
- Planer & Jointer Knives
- CNC Spiral & Compression Bits



QUICK TURN-AROUND & COMPETITIVE PRICING

Connecticut Saw & Tool is one of the most experienced and capable tool sharpening facilities in the U.S. Professional woodworkers from all over the country send their woodworking tools to CST. We pride ourselves on our decades of experience, as well as using the best equipment available. Our highly trained staff utilizes fully CNC controlled machinery, ultra high grit diamond wheels and oil coolant ensuring your

100% satisfaction guaranteed!

We also offer the BEST tooling with the BEST discounts from top manufacturers - in stock & ready to ship same-day!

Call or email for pricing & up-to-date availability



Call Today! 800.404.1220
Free Shipping One Way

140 Avon Street • Stratford, CT 06615
info@ctsaw.com • www.CTSAW.com

CONTINUOUS LIGHT.
COMPLETELY SIMPLIFIED.

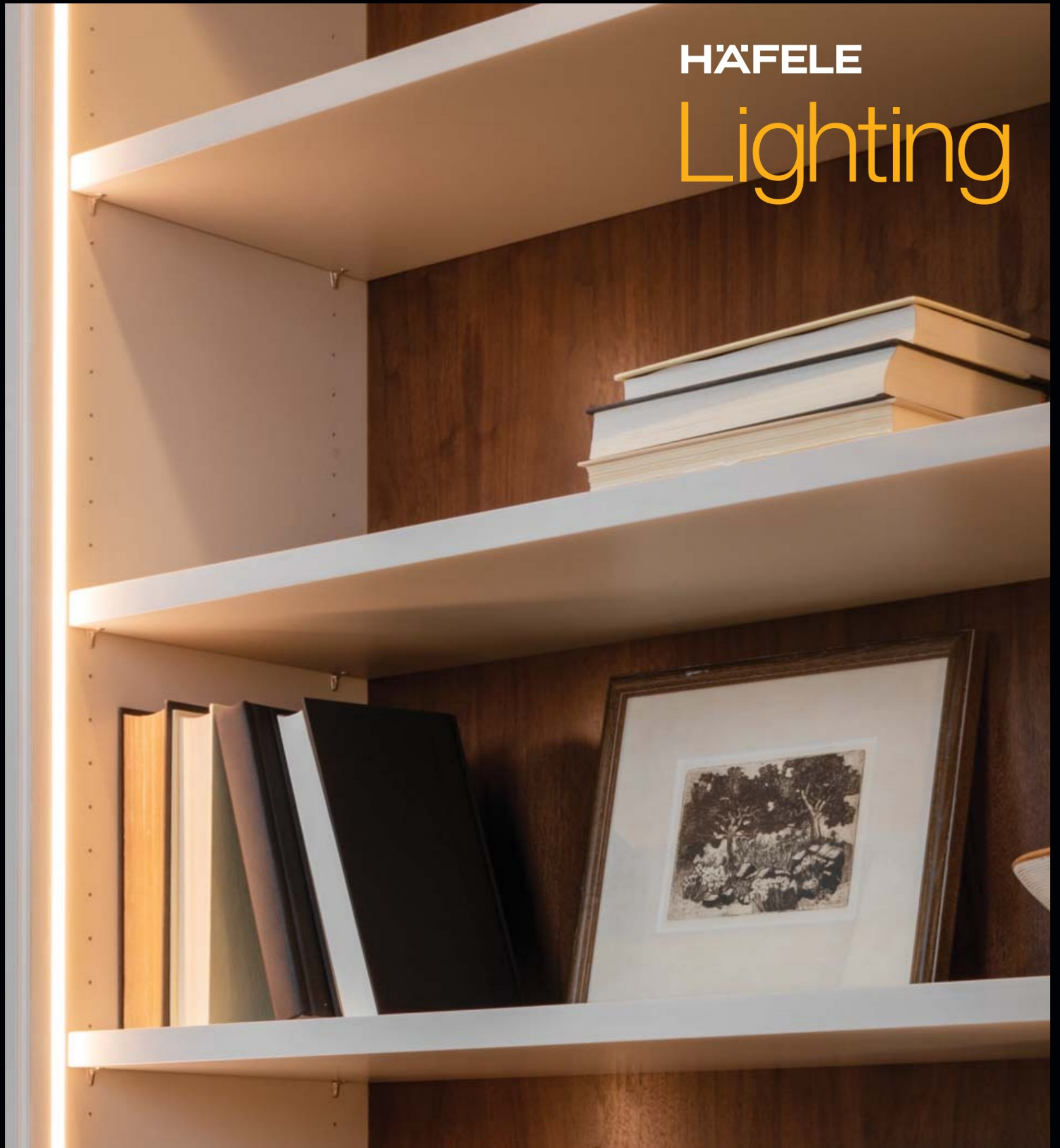

HÄFELE
Lighting

Häfele Lighting takes lighting performance to the next level with elite products such as Chip-on-Board (COB) Complete strip lighting. Achieve seamless, perfectly uniform lines of light within your designs with the ready-to-install COB Complete LED light strips from Häfele. With pre-attached leads and availability in 24V monochrome and tunable white, COB Complete provides not only functionality but also a beautiful aesthetic touch to your next closet design.

Also check out our COB Gold for precision applications that demand flexibility.

- > Continuous contacts allow LED strip to be shortened to exact lengths
- > Short distance between cut points (1" or less) minimizes potential for dark spots
- > Compatibility with ultra-shallow profiles

NEED EXPERT LIGHTING SUPPORT?

Let Häfele's Lighting Design Service create a complimentary plan tailored to your vision – with product selection and pricing to match.

Online & Live Chat: www.hafele.com
Phone: 800.423.3531 | Email: experts@hafele.us

Maximizing
the value of space.
Together.



Tools & Techniques

- 14 Grizzly introduces a new benchtop CNC router system.
- 14 Metabo HPT adds stapler to cordless lineup.
- 16 Oliver jointers get a refresh.
- 17 Oneida adds XT14 cyclonic dust extractor.
- 18 **FINISHING:** Clearing up 'clear' coatings.

Departments

- 6 Taking Stock
- 26 At the Galleries
- 47 New Products
- 50 Calendar
- 53 Marketplace
- 55 Advertiser Index
- 56 Out of the Woodwork

Visit us online at www.woodshopnews.com

BLOGS



Over the Workbench

Talkin' shop with former editor A.J. Hamler

2026 Online Resource Guide
<http://resourceguide.woodshopnews.com>

- **Contact Customer Service**
www.woodshopnews.com/subscribe
- **Tools & Machinery**
www.woodshopnews.com/tools-machines
- **Contact the Staff**
www.woodshopnews.com/contact-us
- **Advertising Information**
www.woodshopnews.com/advertise

SANDING FINISHES



No matter how well you do in the design and assembly of your latest wooden work of art, the final finish has to reflect the same quality. A large part of the finishing process is thoroughly sanding the raw wood and then sanding and smoothing each subsequent coat of finish.

You simply can't beat the performance of silicon carbide abrasive grit for sanding finish coats. Where other abrasive grains are blocky and provide more of a gouging or scratching of the material, silicon carbide is a very hard and sharp abrasive that cuts the material cleanly. This provides a much cleaner and more even scratch pattern that works well for most types of finishes.

To further enhance the finishing characteristics of silicon carbide, the backing becomes a key player, as well. On paper and film-backed sandpapers, the backing is flatter than typical cloth backings. This provides the perfect substrate on which to apply abrasive grains and end up with a layer of grit that will supply an even scratch pattern on any finish.

Klingspor's PS11 silicon carbide sandpaper provides a layer of grit evenly coated on a latex-impregnated A or C-weight paper that can be used either wet or dry on wood finishes or epoxy resin.



"Call to speak with one of our technical advisors about your project."
 – Nick, Technical Advisor



KLINGSPOR
 The Most Sanding Power for Your Money Since 1893!

800-645-5555 • www.klingspor.com



Stiles Machinery to host Manufacturing Solutions Seminar

By Tod Riggio

Stiles Machinery has opened registration for its Spring Manufacturing Solutions Seminar, taking place April 1-2 at its facility in High Point, North Carolina. The two-day event will bring together manufacturers, business owners and industry professionals from across North America to explore advancements in automation, production efficiency and integrated manufacturing technology.

The first day will highlight innovations in surface finishing and solid wood technologies. The second day will focus on panel processing, robotics, and production cell automation.

Topics include compact manufacturing solutions; networked production cells; robotic sorting for assembly; nested-based machining; 'smart' material handling systems; production and optimization software; automated solid wood processing; skilled labor shortage solutions, and advanced sanding and finishing technologies.

"It is always a privilege to welcome so many manufacturers to our High Point facility for the Manufacturing Solutions Seminar," said Sylvain Dubuc, regional director of Stiles Machinery's Southeast region. "Given today's market pressures, innovation can't just be a hope or aspiration; it must be a priority. This event is the best way to experience firsthand the latest in integrated automation and advanced production technologies and understand the impact they can have on performance and long-term business growth."

The seminar is free to attend. Registration is open at stilesmachinery.com/mss, though space is limited.

The **Cabinet Makers Association** will host a regional event in the Greater Philadelphia Area on April 27-29. It will highlight the area's strong woodworking heritage while providing attendees with practical insights they can bring back to their own shops.

"This regional gathering is designed to foster meaningful peer-to-peer engagement while showcasing the craftsmanship, processes, and business practices that define our industry. Attendees can expect a mix of facility tours and informal networking, offering both technical takeaways and practical business insights you can apply right away," according to the CMA.

Attendees do not need to be CMA members to participate.

Event highlights include guided shop tours of Village Handcrafted Cabinetry in Lansdale; Paul Downs Cabinetmakers in Bridgeport; Seven Trees Woodworking in New Holland; Keystone Wood Specialties in Lancaster, and Fox Woodworking in Phoenixville.

The event will also offer peer-to-peer networking opportunities; in-depth conversations focused on operations, workforce, craftsmanship, and business best practices, and an optional group activity offering additional design and craft inspiration.

"Regional events are one of the most valuable ways our members learn from one another," said Amanda Conger, Executive Director of CMA. "They create space for honest conversations, idea-sharing, and relationship-building that simply can't happen in any other setting."

Learn more and register at cabinetmakers.org. **W**

EDITOR TOD RIGGIO
ART DIRECTOR CHRIS CIRILLI
STAFF WRITER JENNIFER HICKS
CONTRIBUTING WRITERS
RALPH BAGNALL, JOHN ENGLISH, A.J. HAMLER,
DIANE SHATTUCK, AND YOAV SAMUEL LIBERMAN

SALES & MARKETING

PUBLISHER
RORY BEGLIN
203-952-6790; rory@woodshopnews.com

CLASSIFIED MARKETPLACE ADVERTISING
203-952-6790
marketplace@woodshopnews.com



SENIOR VICE PRESIDENT, CONTENT **ROB YAGID**
GROUP ADVERTISING DIRECTOR, WOODWORKING
ALEX ROBERTSON
DIRECTOR, DATA, AUTOMATION, AND AUDIENCE
MATTHEW BOYLES
ADVERTISING SALES COORDINATOR **JULIE DILLON**
CIRCULATION, FULFILLMENT MANAGER **JAMES JACKSON**
DIGITAL INFORMATION & MARKETING TECHNOLOGY MANAGER
DORIAN HENAO



CHAIRMAN & CEO **ANDREW W. CLURMAN**
CHAIRMAN EMERITUS **EFREM ZIMBALIST III**
CHIEF FINANCIAL OFFICER **ADAM SMITH**
SENIOR VICE PRESIDENT, MARKETING **ERICA MOYNIHAN**
VICE PRESIDENT, CIRCULATION **PAIGE NORDMEYER**
SENIOR VICE PRESIDENT, SALES **MIKE BURNS**
VICE PRESIDENT, SALES OPERATIONS **CHRISTINE NILSEN**
VICE PRESIDENT, DIGITAL PRODUCT DEVELOPMENT **ASHLEY MACDONALD**
VICE PRESIDENT, STRATEGY & RESEARCH **KRISTINA SWINDELL**
DIRECTOR, HUMAN RESOURCES **SCOTT ROEDER**
DIRECTOR, PRODUCTION **PHIL GRAHAM**
DIRECTOR, RETAIL SALES **SUSAN A. ROSE**
TECHNOLOGY OPERATIONS ANALYST **MICHAEL LEWIS**

HEADQUARTERS:

Active Interest Media 2143 Grand Ave. Des Moines, IA 50312
Editorial E-mail: editorial@woodshopnews.com
Advertising E-mail: sales@woodshopnews.com
Website: www.woodshopnews.com
Advertising Billing Questions: (661) 965-9925

SUBSCRIPTION SERVICES:

For questions, problems, or changes to your Woodshop News subscription,
Online: www.woodshopnews.com/customerservice
Call: 800-243-9177
EMAIL: subscriptions@aimmedia.com
write: Woodshop News, PO Box 433212, Palm Coast, FL 32143-3212
Canada Post Return Address undeliverable to:
APC-PLI, P.O. Box 503, RPO West Beaver Creek,
Richmond Hill, ON L4B 4R6.
Canada Post Publication Mail Agreement No 40624074.

Learn more
shapertools.com/applications/hardware



GO AHEAD... THROW AWAY YOUR TEMPLATES

Shaper Origin is a handheld CNC router that makes specialty hardware installation and other precision cutting tasks easy and accessible.

Install hardware in virtually any workpiece with hundreds of verified cut files from top manufacturers, provided for free in Shaper's Hardware Catalog. Search for the file you need; align Origin with a simple pencil mark; begin cutting in minutes.

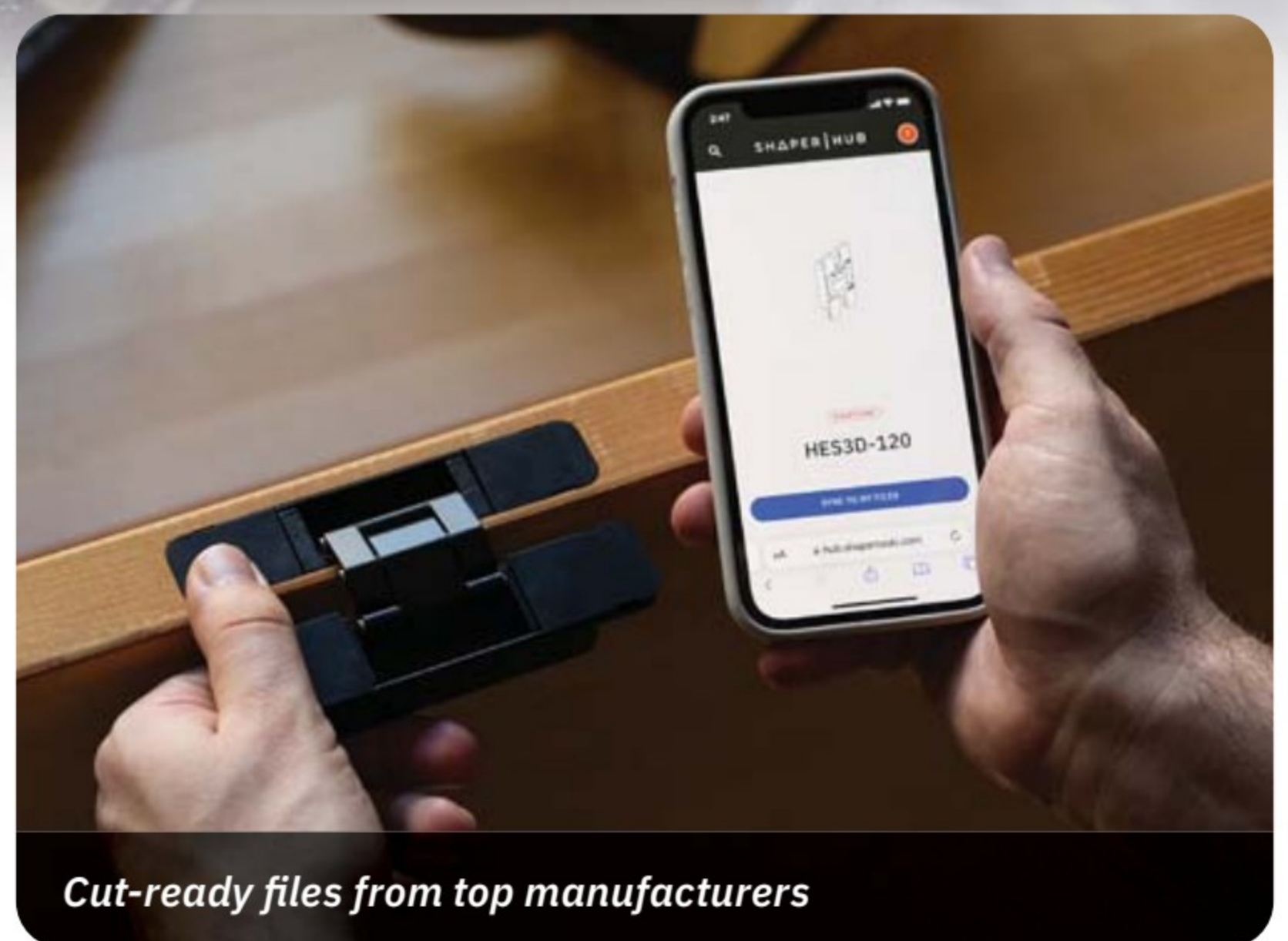

Cut-ready files from top manufacturers

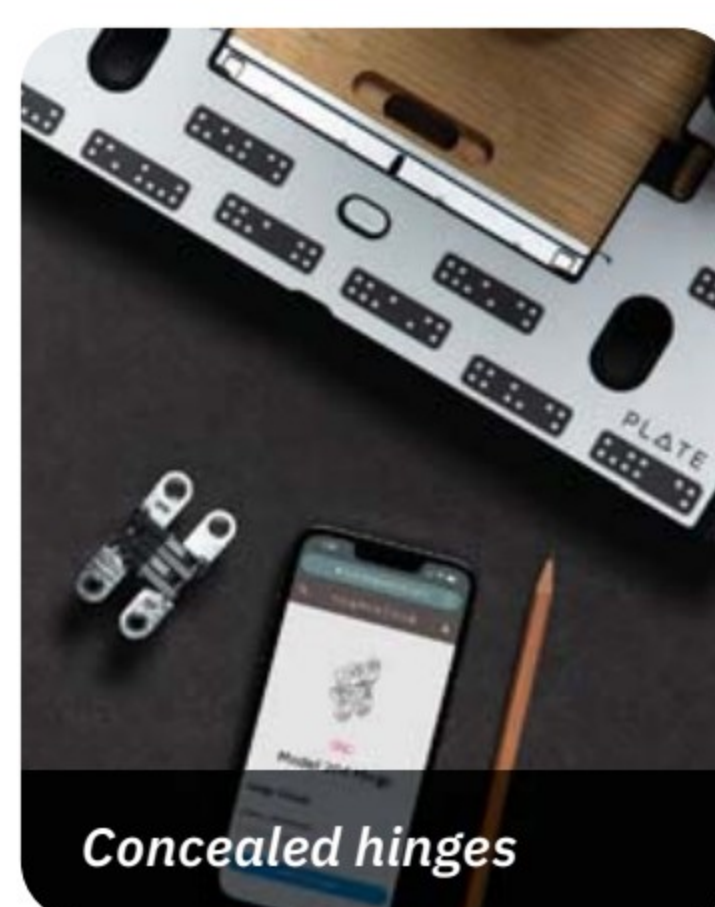

Concealed hinges



Flush mount pulls



PRECISION CUTTING SIMPLIFIED

Builders' show fuels homebuilding momentum

By Jennifer Hicks

Nearly 75,000 registrants packed the exhibit halls at the Orange County Convention Center in Orlando from Feb. 17-19 as the National Association of Home Builders hosted its International Builders' Show, underscoring strong demand across the construction and homebuilding sectors.



Attendees converge at the International Builders' Show in Orlando to explore the latest trends in homebuilding.

IBS joined forces with the Kitchen & Bath Industry Show for the 13th annual Design & Construction Week (DCW), drawing nearly 117,000 registrants. The event marked the final DCW in Orlando before the show moves to Las Vegas next year.



"This year's attendees have been excited and engaged — a reflection of the overall industry's desire to get out there and build," Geoff Cassidy, NAHB chief revenue officer, said in a statement. "Orlando has been a great partner for the show, so we're thrilled to host such a strong final event here."

IBS spanned 679,000 sq. ft. of exhibit space, where 1,650 exhibitors showcased the latest building products,

materials and technologies. Among the new attractions was the AI & Tech Studio, featuring hands-on demonstrations and real-world case studies highlighting how advanced tools are reshaping home construction.

DCW featured 2,250 exhibitors across 1.15 million sq. ft. of indoor and outdoor exhibits, making it one of the industry's largest gatherings.

Beyond exploring product launches and supplier booths, attendees connected with peers and participated in more than 120 education sessions covering industry topics.

The next Design & Construction Week is scheduled for Feb. 2-4, 2027, in Las Vegas.

Learn more at nahb.org. **W**



Sponsored By:

POWERMATIC



For over a century, Powermatic has set the gold standard in woodworking machinery. Since 1921, the name Powermatic has represented precision, durability and pride in craftsmanship. In workshops and at industry gatherings across the country, woodworkers speak to what it means to own a Powermatic machine—pride that’s earned, not given. Today, the company is building on that legacy with a renewed focus on deepening its connection to the woodworking community and redefining what ownership truly means.

At the center of this evolution is the initiative known as “The Powermatic Difference.” Years in the making, this strategy reflects a realignment with the company’s roots: producing premium machines while delivering an exceptional user experience. Rather than chasing short-term change, Powermatic is taking a holistic approach—supporting woodworkers before, during, and long after a machine enters the shop. This goes from large commercial shops with dozens of tools, to small shops at home.

Behind the scenes, product innovation remains core to the brand. Powermatic is rolling out updated machines, starting with lathes and planers. Larger digital readouts, improved dust collection, and durability-focused design updates reflect a continued commitment to thoughtful engineering. At the same time, Powermatic is refining its most trusted machines to ensure the tools woodworkers rely on continue to perform at the highest level.

An expanded commitment to service and support is equally important as the machine itself. Powermatic has streamlined their five-year warranty across the board with coverage to protect you, your investment and day-to-day operations. This includes an option to extend protection out to 10 full years and provide preventative maintenance plans further supporting long-term ownership.

With this commitment, Powermatic is redefining the customer journey. An updated website will offer a more seamless experience. This new website will include features such as extensive educational content, mentor profiles, and a customer service chat agent powered by AI that will allow order tracking, case creation, returns, and product assistance help. For the first time, customers will be able to purchase new machines directly from Powermatic.com, in addition to your local dealers.

Beyond products and policies, Powermatic is deepening its connection to the woodworking community. Collaborations with respected makers, educators, and craftsmen, like you, highlight the real-life impact of quality tools. From professionals to hobbyists, these voices underscore woodworking as more than a trade—it’s a craft, a passion, and often a source of purpose.

This renewed direction isn’t a single campaign. It represents an ongoing commitment to innovation, partnership, and user-focused design—reinforcing what has always set Powermatic apart: machines built with intention, supported with integrity, and trusted by generations proud to bring gold into their shops.



**MEET THE NEW POWERMATIC AT
WWW.POWERMATIC.COM**

SPONSORED CONTENT

C.R. Onsrud opens expanded facility for annual Demo Day

By Jennifer Hicks

C.R. Onsrud, a CNC machinery manufacturer, hosted its annual Factory Demo Day on March 25 at its Troutman, North Carolina, facility. The event connects manufacturers to share ideas and explore new technologies.

"Adding the 83,000-square-foot expansion last year has really helped the event grow," says Jeff Onsrud, director of sales and business development. "We're excited to welcome more manufacturers, bring in more vendors and expand our offerings."

Attendees viewed live demonstrations of 3- and 5-axis machines and spoke with vendors representing CAD/CAM software, automation, CNC tooling, vacuum pumps and other CNC-related technologies. Educational seminars were also offered.

"Essentially this is a mini trade show. Anything and ev-



Attendees toured the working factory and met vendors.



everything related to the CNC world will be at C.R. Onsrud. It's a great way to learn something new, even if you have owned a CNC router for decades," said Thomas Tuck, senior manager of regional sales and marketing initiatives.

Attendees toured the 250,000-sq.-ft. manufacturing space, including the fabrication shop and production floors, while the factory operated at full capacity.

The company also marked its 50th anniversary during the event.

Learn more at cronsrud.com. **W**

APOLLO SPRAYERS CELEBRATES 60 YEARS

Apollo Sprayers marks 60 years of manufacturing high-volume, low-pressure (HVL) electric paint sprayers, evolving from a 500-sq.-ft. warehouse into a manufacturer serving the automotive, woodworking and professional paint industries.

Founded by John B. Darroch, the Vista, California-based company faced early challenges when imported spray systems weren't compatible with North America's 110-volt electrical standard. Apollo responded by importing component kits and sourcing motors

domestically, assembling systems in the United States to reduce costs and improve quality control.

The company expanded from its original Fountain Valley warehouse as demand grew, maintaining family ownership through three generations.

Apollo's systems demonstrated transfer efficiency rates above 80 percent in independent laboratory testing, according to the company. Transfer efficiency measures how much paint reaches the surface versus becoming overspray. The company says this efficiency can reduce

coating costs by up to 40 percent.

For woodworkers, higher transfer efficiency means less overspray and reduced material waste. Automotive refinishers gain better control when spraying metallics, pearls, and clear coats.

"Our 60-year milestone represents more than longevity," said John A. Darroch, president and CEO. "It represents relationships with our customers, employees and industry partners. We have always focused on building systems that deliver real performance benefits."

Learn more at hvlp.com.

EXCELLENT ACCURACY & RELIABILITY

*Quality machines with
proven performance.*



grizzly.com/shopfox

**TWO-
YEAR
WARRANTY**



Available at these fine retailers:

grizzly.com

JB TOOLS

ACME TOOLS

THE TOOL NUT

& MORE!
See website for details

Butternut supply keeps dwindling

By Jennifer Hicks

Butternut, also known as white walnut, was once a widely available domestic hardwood. The species (*Juglans cinerea*) has been devastated by butternut canker, a fungal disease that has led to a rapid decline in its population and availability. Lumber suppliers say the scarcity has left their shelves nearly bare.

Matt Ronsani of Berkshire Products in Sheffield, Mass., says seasoned woodworkers are generally aware of the situation, while emerging craftspeople sometimes aren't familiar with the species.

"We're kind of at the point where customers don't even ask about it anymore because they don't know if it's even available, and it kind of isn't," Ronsani says. "With butternut, we'll occasionally get logs, and since we specialize in live edge slabs, most of it goes to slabs. We do have some butternut slabs, but as far as butternut lumber, sourcing it is very hard."

He says the company occasionally gets requests for butternut paneling, particularly tongue-and-groove styles that customers prefer for its rustic appearance.

"Furniture makers like to use butternut. We're in with the Berkshire Woodworkers Guild, and a lot of them have made butternut furniture, but they say sourcing material is just very hard in this part of the country."

Butternut generally grows in the Eastern U.S. and has a typical width of 5 to 12 inches and an average length of 8 to 12 feet. It's favored for its light to medium tan color with distinct grain patterns.

Chad Muterspaw of CR Muterspaw Lumber in Xenia, Ohio, says logs are scarce, but some customers still request it for its softer density for carving and because it resembles antique walnut lumber.

"It's been a challenging one for sure with availability. We still carry it. It's just harder to find those logs, and there are



fewer sawmills cutting it, but we do have some inventory," Muterspaw says. "We've got a few customers that are looking for it, but it's definitely more of a niche species."

He says carvers and antique reproduction craftspeople particularly seek butternut for its workability and appearance.

"It's kind of that blond walnut look, so you can build a new piece out of butternut and match old walnut as it bleaches out over the years," he says. "It's a little on the softer end, but workability is good. They can hand-tool it well."

Muterspaw adds that pricing has remained steady and generally follows walnut pricing trends.

Bob Laurie of L.L. Johnson Lumber Mfg. Co. in Charlotte, Mich., says he usually tries to buy Select & Better butternut but currently has nothing in stock.

"We've been looking for it for a year. Other than some really low-grade stuff, I've not been able to find any," Laurie says. "The problem is we never really sold a lot even when we could get it. Then it just got to the point where some of the people we used to buy it from don't even respond to requests."

Retail quotes for 4/4 FAS butternut started at \$7.65/bf. **W**

Moisture Meters

Pinless, Pin and Hygrometers

Choose Lignomat for Reliability, Accuracy and Competitive Prices.

Questions about which meter to buy, call and talk to our experts.

800-227-2105
www.Lignomat.com



Pin or Pinless - Your Choice

Pin meters are more versatile. They measure all thicknesses of wood, a wide moisture range from dry to wet and all shapes from flat boards to round shapes.

Pinless meters are very convenient. A lot of boards can be measured in a short time leaving no pin holes, but pinless meters require a flat measuring surface.



Lignomat

Wood machinery leaders to gather in Puerto Rico ahead of IWF

By Jennifer Hicks

The **Wood Industry Association** will host its annual Wood Industry Conference May 5-7 at the El Conquistador Resort in Fajardo, Puerto Rico. The event brings together wood-working machinery importers, manufacturers, distributors and suppliers.

"We're especially excited about our offerings for distributors at this year's WIC. We have a robust program that includes a moderated distributors panel highlighting the value that our distributors bring to the channel; a strong emphasis on our Contact Table networking program; and the second year of our Distributors Forum, which is a half-day program dedicated to distributor members," says Fred Stringfellow, CEO of WIA.

The International Woodworking Fair, scheduled for Aug. 25-28 in Atlanta, is helping build attendance momentum, Stringfellow adds.



"With IWF taking place later this year, we're expecting a strong turnout of distributors as manufacturer and importer exhibitors synchronize with their distributor partners prior to the show. Early registration numbers are reflecting a significant increase in WIC attendance this year," he says.

The program includes networking sessions and keynote speakers addressing business strategies.

This year's keynote speaker Nick Tasler will present on how embracing change drives sustained success. Tasler is an organizational psychologist who has worked with FedEx, Microsoft, JPMorgan Chase and other companies.

Other speakers include Shawn DuBravac, a futurist and author; Mary Kelly, who specializes in leadership development; and Connor Lokar, an economist with ITR Economics who provides economic analysis at events across North America.

Panelists include moderator Madison Burt of WEIMA America; Jason Dingess of Quis Machinery; West Love of Taurus Craco Machinery, and Chris Timmer of Scarlett Machinery.

Learn more at woodindustry.org. **W**

APRIL 2026

13

WOODSHOPNEWS

NEW CNC ROUTER? PERFECT TIMING FOR LOCKDOWEL!



Invisible, glue-less, tool-less fasteners for super fast and simple assembly. Up to 60% time and labor savings!

Why mess around with old-fashioned dowels, glue, and case clamps when Lockdowel has clear advantages: higher quality, durability, disassembly when needed, flat-packing capability, and it's so easy to use, anyone can do it! Lockdowel's invisible fasteners can be used for cabinetry, closet, and furniture applications. It's truly a revolutionary system for maximum profits.

Learn more now!

Lock In More Profit.
LOCKDOWEL™



www.lockdowel.com | 866.389.5393

Patented • Tested • Proven

Charlotte, NC • Hayward, CA

© 2026 Lockdowel, Inc.

IS LOCKDOWEL YOUR ANSWER?

- Do you have a CNC router?
- Do you have edge boring capabilities?
- Do you use woodworking software?

Then you're ready to save with Lockdowel!

Grizzly introduces a new benchtop CNC router system

By Jennifer Hicks

Grizzly Industrial has launched the G0403 Benchtop CNC Router System, a user-friendly precision machine designed to deliver professional-grade automated performance to hobbyists, educators, and small businesses. Built as a scalable platform, the G0403 can evolve with the user through modular upgrades.

"The G0403 offers professional-grade precision in a compact footprint, making it ideal for prototyping, crafting intricate designs, and transforming creative concepts into finished products. It is engineered for makers who seek performance and reliability without compromising workspace," stated Mike Bergman, product manager for Grizzly Industrial.

The G0403 features a 65mm spindle mount suitable for the user's personal handheld router or spindle. The machine includes automated setup, a handheld DSP control-



The G0403 is an expandable system with 4th axis and water-cooled spindle options.

ler, and a 15.75" x 36" anodized aluminum table. Its overall dimensions are 24" wide, 36.5" deep, and 27" high.

Additional features comprise an automatic tool setter for rapid, precise setup; ball screw drives on all three axes, and a steel gantry. It also includes V-Carve CAD/CAM desktop software and a 3.5" LED touch screen.

An optional upgrade is the T34438 2-hp Water-Cooled Spindle Kit, priced at \$875, for continuous-duty cutting. The integrated water-cooling system sustains constant operation temperatures for extended spindle life and enhanced surface quality, according to the company.

The system also supports the T34439 4th-Axis Rotary Kit, available for \$860, which introduces multi-dimensional carving capabilities.

The Benchtop CNC Router System is priced at \$3,450 and includes the 65mm spindle mount, touch plate, M6 clamping kit, and V-Carve software.

Learn more at grizzly.com. **W**

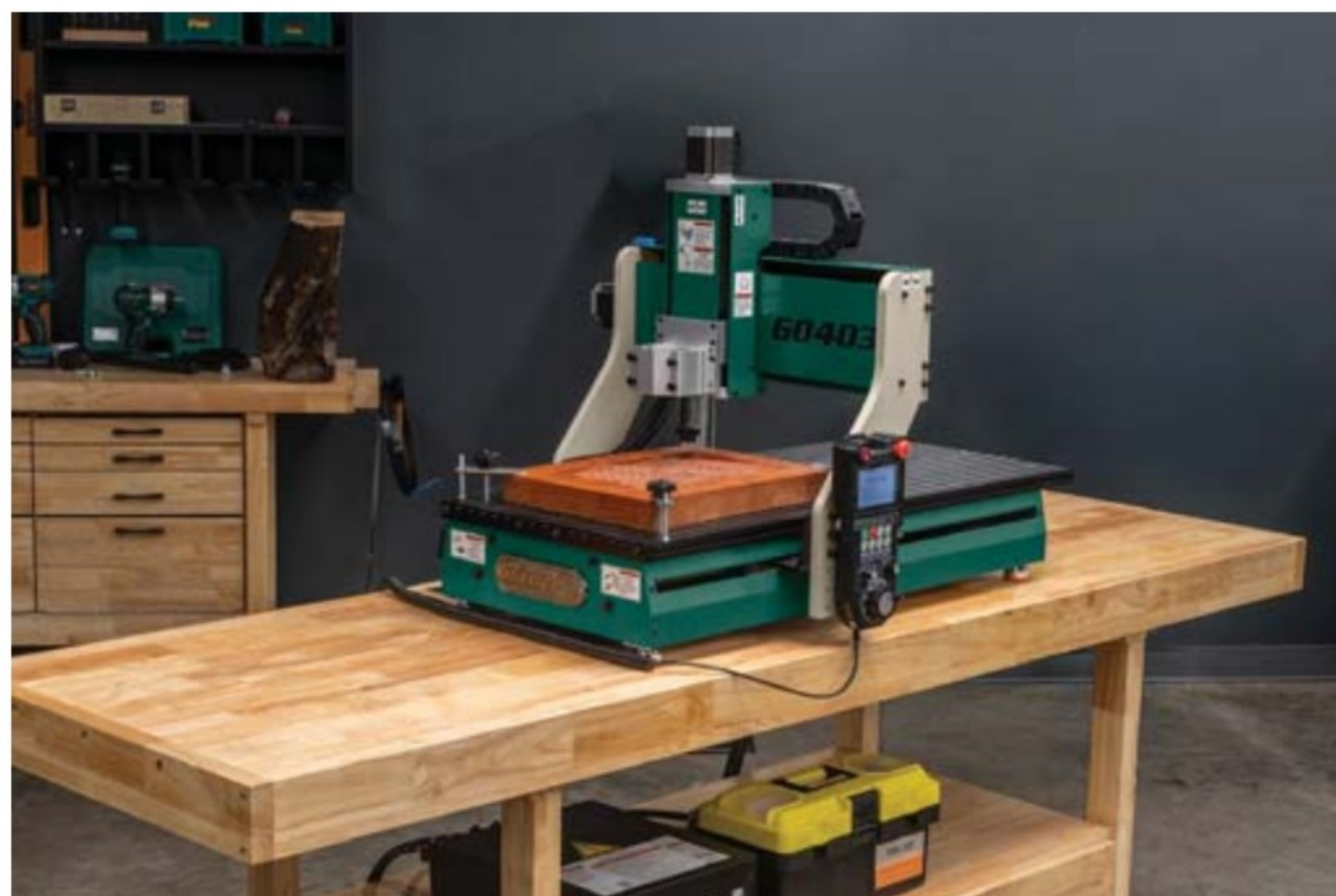

14 APRIL 2026 WOODSHOPNEWS

Metabo HPT adds stapler to cordless lineup

By Jennifer Hicks

Metabo HPT has introduced its 18-volt, 16-gauge crown stapler, expanding its cordless lineup.

Powered by Metabo HPT's Air Spring Drive System, the stapler fires 1- to 2-inch 16-gauge, 7/16-inch staples with no ramp-up time, reaching up to three staples per second, according to the company.

The tool features a brushless motor for enhanced run-



time and durability while reducing maintenance requirements. Low-noise, low-exhaust operation improves comfort during extended use.

Additional features include an LED work light, toolless depth adjustment, selective firing, and toolless jam clearing.

Beyond trim, molding and cabinetry, the stapler handles sheathing, subfloor installation, fencing, house wrap and insulation applications, the company said.

The stapler, model N1808DA, carries a suggested retail price of \$479.

Learn more at metabo-hpt.com. **W**

Courtesy of manufacturers

The Newest Wood Care Products



In A Family of Great Products!

100% PURE TUNG OIL

The #1 Natural Way To Enhance the Grain in Wood!

The Perfect Finish
For All Types of Wood!

FILTERED • NO ADDITIVES

A Hand-Rubbed Finish
Professionals Call "Money Oil!"

NO FILLERS • NO DRYERS

Nature's Best Wood Protector:

- ✓ Water Resistant
- ✓ Insect Resistant
- ✓ Revitalizes Dry Wood

*"Tung Tree
Nut Extract
Restores Richness
& Vitality
To All Types of Wood."*



Great for All Wood Furniture:

- ✓ Natural Matte Finish
- ✓ Non-Toxic / No VOCs
- ✓ Non-Yellowing Oil

*"Choose
PURE TUNG OIL
Instead of Blends
that can Wrinkle
& Dry Out Finishes."*



BRIWAX 100% Pure Tung Oil penetrates deeply into the wood pores, bonding with it at a molecular level, strengthening and enhancing the wood. This all-natural, hand-rubbed look brings out the natural beauty of the grain and is easily refreshed with just another single coat as needed. **BRIWAX Pure Tung Oil** produces a natural patina that ages with the wood, preventing the dull, worn-out look that can occur with most surface-type finishes. A non-toxic, "food-safe" oil for refinishing countertops, tables, cutting boards and any wood surfaces that come in contact with food or skin.

From the Maker's of



OTHER BRIWAX WOODCARE PRODUCTS:

- BRIWAX ORIGINAL PASTE WAX
- BRIWAX SPRAY WAX
- METAL POLISH & MULTI-SURFACE RESTORER
- ULTRA-MAGIC MICROFIBER DETAILING CLOTH
- BULK BEESWAX PELLETS
- OIL-FREE STEEL WOOL
- WATER-BASED WOOD-DYE
- SHERADALE WAX - ANTIQUE RESTORER
- NATURAL CREAMED BEESWAX
- MTD - JOINT BONDING AGENT
- GUNSTOCKRX - RESTORES WOOD GUNSTOCKS & KNIFE HANDLES
- CHAIRX - FIRST AID FOR CHAIR & TABLE LEGS
- SHELLAC SANDING SEALER
- TEAK OIL
- LIMING WAX
- HARD WAX OIL
- GRAIN FILLER
- WAX FILLER STICKS
- TAMPICO BRUSHES
- EZ-SWIPES - CLEANING WIPES

AVAILABLE ONLINE OR
Contact Your Local Retailer or Distributor!

BRIWAX.COM • 1-800-527-4929

Oliver jointers get a refresh

By Jennifer Hicks

Oliver Machinery has revamped its popular 6-inch and 8-inch parallelogram jointer models, replacing the older versions with enhanced designs that include relocated power switches and increased horsepower for greater cutting capacity, according to the company.

"Oliver's 6-inch and 8-inch jointers were updated based on user feedback," says Gregg Healy, Oliver's marketing director.

"We relocated the power switch and shut off to a perch, similar to our larger jointers, to avoid accidental shutoffs and to be more user friendly. The relocated switch assembly is also available separately for current owners. We also added more power to each machine, up from 1 to 1.5 horsepower for the 6-inch and from 2 to 3 horsepower on the 8-inch, to help with harder woods, wider cuts and deeper passes without sacrificing long term reliability. Crating has also been updated with heavier materials."

Both jointers now feature Oliver's HCX helical cutterhead, which uses four-sided carbon inserts, rather than the previous linear spiral design.



Oliver's new 6-inch parallelogram jointer, model 4225.215.

Standard features also include extra-long precision-ground tables, cast iron frames for table support, a parallelogram design for smooth and accurate cuts, a large, lockable pedestal-mounted paddle on/off switch, a fully enclosed cabinet with a 4-inch dust port, a built-in mobile base with lockable wheels, lever-controlled infeed and outfeed table adjustments, a fence that tilts up to 135 degrees with positive stops at 45 and 90 degrees, an easy-read depth of cut gauge, and poly V-belt drives.

The 6-inch parallelogram jointer, model 4225.215, replaces the 4425.201 and is priced at \$2,500. The 8-inch model 4235.230 replaces the 4325.201 and is priced at \$3,750.

Learn more at olivermachinery.net. **W**



16 APRIL 2026 WOODSHOPNEWS

REGISTRATION OPENS FOR 2026 NWFA WOOD FLOORING EXPO

The National Wood Flooring Association has announced that registration is now open for the 2026 Wood Flooring Expo, scheduled for April 21-23, 2026, at the Orange County Convention Center in Orlando, Florida. The NWFA Wood Flooring Expo is the largest trade show and conference worldwide dedicated exclusively to wood flooring.

With the theme "Ignite Your Passion," the 2026 expo focuses on reconnecting with the core purpose behind the work and transforming that energy into meaningful action for wood flooring professionals.

"The 2026 Expo theme, Ignite Your Passion, is about reconnecting with why we do this work and turning that energy into action," said Stephanie Owen, NWFA president and CEO. "The 2026 Expo offers an unmatched opportunity to learn

from industry leaders, strengthen professional connections, and explore the innovations shaping the future of wood flooring. Orlando provides an ideal setting for that experience, bringing together world-class facilities, accessibility, and an atmosphere that encourages both focus and inspiration. Attendees will leave reenergized, informed and ready to move their businesses forward."

The expo will feature education sessions designed to help attendees sharpen technical skills, grow their businesses and stay ahead of market trends, along with new product demonstrations and trade show floor exhibitions. Attendees will also have networking opportunities and can see the announcement of the 2026 NWFA Wood Floor of the Year winners.

Learn more at 2026.nwfaexpo.org.

Oneida adds XT14 cyclonic dust extractor

By Jennifer Hicks

Oneida Air Systems has introduced the XT14 Cyclonic HEPA Dust Extractor, a portable unit that combines the company's cyclone technology with a HEPA vacuum. The integrated unit is designed for hand-held and benchtop tools as an upgrade to standard wet/dry vacuums.

"The XT14 features our highly engineered cyclone that's designed to separate over 99 percent of all the dust and material from the airstream into the 14-gallon drum," says Alex Witter, Oneida's general manager.



Oneida's new XT14 Cyclonic HEPA Dust Extractor.

"This system maintains and prolongs the airflow, compared to using a traditional wet/dry vacuum for woodworking operations where the air is being pulled straight from your shop and into your filter, which clogs it and causes an immediate performance drop-off."

The cyclone separator blocks up to 99.9 percent of dust from clogging the filter, according to the company. A 110-volt fan motor delivers up to 128 actual cubic feet per minute (CFM) through 2.5-inch and smaller ports. The 14-gallon waste bin includes a dust level viewing window and moves on five locking casters. The unit weighs 44 pounds and measures 22" wide, 21" long and 38" tall. It handles dry dust such as wood, drywall, and concrete but is not suitable for wet materials.

The XT14 offers an alternative to Oneida's Dust Deputy, a wet/dry vacuum attachment that separates material through a cyclone but lacks integrated components.

"The XT14 stems from our customer feedback. For a long time, our customers have been asking for an integrated cyclonic vacuum unit, because with the Dust Deputy and a wet/dry vacuum, it can get clunky with two units pulling them around the shop," Witter says. "It works really well and maintains your airflow of your wet/dry vacuum, so basically we combined an industrial-grade HEPA cyclonic dust extractor, which is the XT14."

Witter adds that the Dust Deputy will remain in production. The Oneida XT14 Cyclonic HEPA Dust Extractor (XDS250014) sells for \$1,149.

Learn more at oneida-air.com. **W**

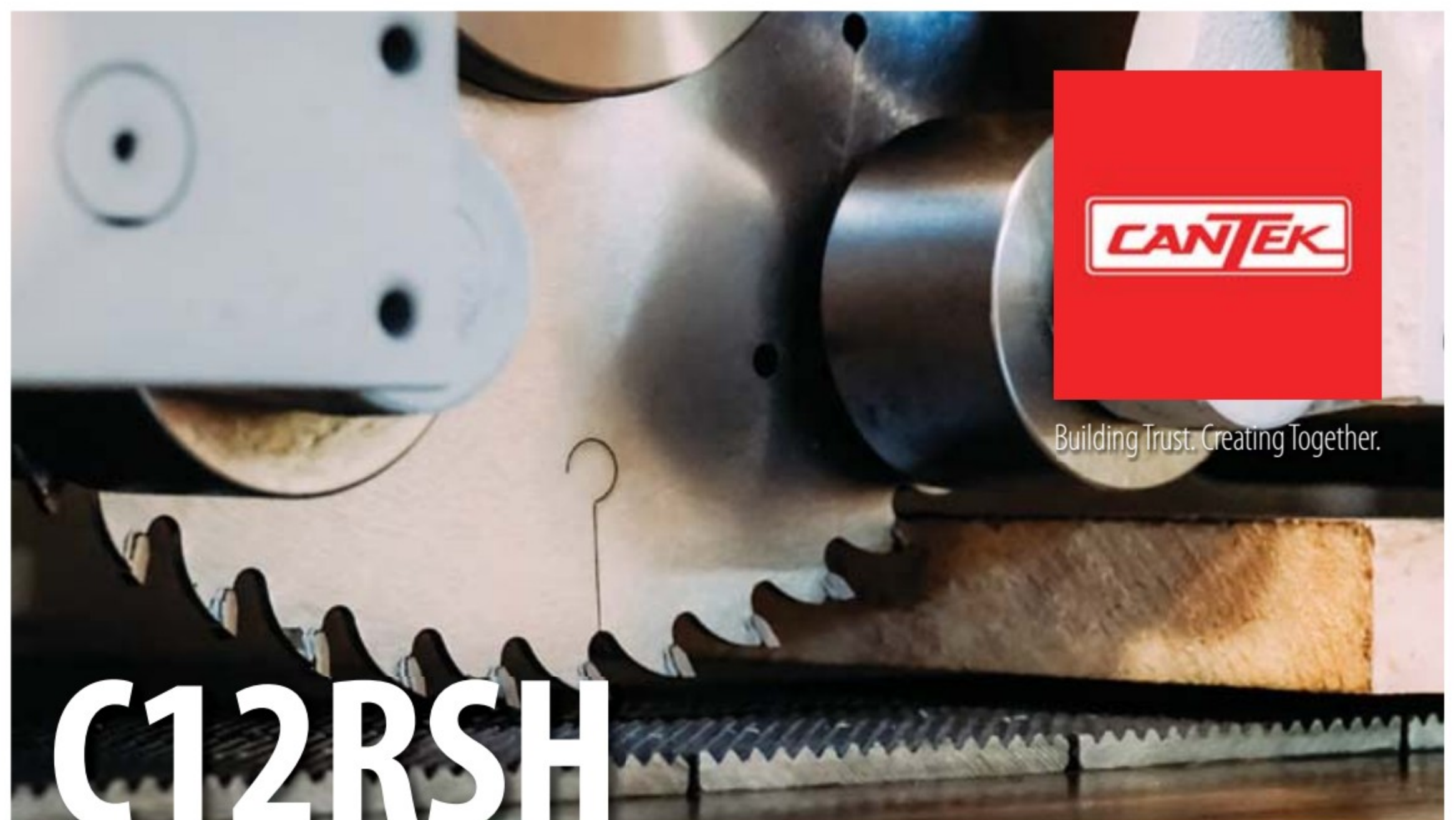

C12RSH

Straight Line Glue Joint Ripsaw

Looking to increase efficiency in your ripping operations? The Cantek C12RSH Single Blade Ripsaw features a precision cast iron chain and track assembly and extended pressure section to produce a glue joint finish ready for panel glue-up right out of the saw.



EFFICIENT | FAST | PRECISE | ACCURATE

Akhurst Machinery Group

cantekamerica.com



Clearing up 'clear' coatings

By Diane Shattuck

How clear is your clear coat?

Have you ever applied a "clear" finish to your project only to watch the wood immediately turn amber? What happened to it being clear?

Clear finishes range from water-clear liquid to a deep amber. "Clear coatings" really means transparent coatings that can be applied over stain or natural wood while preserving visible grain and texture.

Coating clarity depends on multiple factors. Clear coatings contain different alkyds, resins and solvents that alter transparency. When you read "clear" on the can or technical data sheet (TDS), you might assume zero discoloration. In reality, the coating may contain alkyds that shift clarity toward amber.

Nothing frustrates woodworkers more than applying a clear finish that yellows or ambers their project. After years as a technical sales representative, troubleshooting customer concerns, I developed a system using soda comparisons to describe clarity: root beer for amber, ginger ale for water white and 7UP for non-yellowing finishes.

When a TDS lists a "clear" finish, it often contains nitrocellulose, which always yellows. Depending on the accompanying alkyd, it can develop a root beer amber cast. This produces a warmer look on stains but appears dirty over whites. Examples include nitrocellulose lacquer, older pre-catalyzed finishes, polyurethane, varnish, shellac, and oils.

"Water white" finishes resemble ginger ale clarity. While you can see to the bottom of the can, they may contain small amounts of nitrocellulose paired with clearer alkyds that cast a slight blue tint. This produces

a cooler look on wood tones and brighter whites. These include some pre-catalyzed lacquers, post-catalyzed lacquers, waterborne finishes, 2K polyurethanes, and polyesters.

"Non-yellowing" clear coats are my 7UP coatings — transparent finishes that minimally shift underlying colors. Examples include wax, CAB lacquers, some waterborne finishes, conversion varnish, and 2K acrylic urethanes.

This decoding system worked well until marketing departments began using multiple buzzwords. For example, a "non-yellowing water white clear" — a contradiction like "jumbo shrimp."

All clear coats affect the final color regardless of clarity. Waterborne clear coats have a milky cast, sometimes with a bluish haze, and can wash out color. Wood species like walnut, mahogany and cherry may appear ashy or plastic depending on the coating. Acrylic-urethane blends (ginger ale) may cause grayish hues, while straight acrylics become clearer (7UP).

Sealers also contribute to clarity shifts. Designed to seal color, dry quickly and aid sanding and adhesion, sealers can turn a non-yellowing system amber if they contain yellowing properties. Some contain stearates that react with topcoats or cause delamination when products aren't compatible. Always use compatible sealers between manufacturers' products and check their clarity.

Film thickness and sheen determine how much the coating magnifies underlying color and grain. Each coat acts like a layer of glass, magnifying what lies beneath and potentially shifting clarity.

Sheens shift clarity depending on

flattening agents used. Some are pastes, other gels — all require thorough mixing to avoid haze spots or float. The agents settle and need gentle agitation throughout application. Finishes are generally manufactured with a gloss sheen, then the amount of flattening agent added into the formula will change the final sheen. Higher sheens brighten colors while lower sheens blend and reduce vibrancy.

Other clarity factors include contamination from mixing containers. Avoid printed mixing cups as ladles — logos can bleed into lacquers, paints or polyesters. Wax-lined drinking cups can cause fisheye.

Solvent blends determine clarity, flow, drying, and other properties. Reducing with solvents affects color in the can, during application and in hiding power. Always use manufacturer-recommended solvents. Using more than 10 percent retarders can increase sheen. Proper solvent blends allow pinholes to seal and surfaces to level before film formation.

To preview coating clarity before application, spray half a board with white paint, leaving half bare. Cover sections of both halves with paper, then apply your coating. When you remove the paper, you'll see the clear finish's color shift. Was it root beer, ginger ale or 7UP? Create a full step panel to ensure desired color and clarity. Remember: "clear" doesn't guarantee zero color shift. **W**

Diane Shattuck is a finisher, consultant, guest speaker, writer and teacher. She can be contacted at dianeshattuck@msn.com. Questions, suggestions and comments are always welcome.

CHEMCRAFT TURNS 50

AkzoNobel's Chemcraft brand is marking five decades in the wood coatings industry.

"Reaching 50 years is a significant milestone for Chemcraft, but it's also a reflection of the relationships behind the brand," said Ron Cooper, Segment Manager – Distribution North America, Furniture & Flooring for AkzoNobel Wood Finishes.

"Our success has always been built on working closely with customers and distributors, and a deep understanding of real-world challenges faced by wood finishing professionals and delivering coatings they can rely on day in and day out. That focus continues to guide how we support our customers today and into the future."

According to the company, continuous investment in product development, technical expertise, and service capa-

bilities has enabled the Chemcraft brand to adapt and grow in a competitive and evolving market. Hands-on technical support, color matching capabilities and local distributor knowledge remain central to how the brand delivers value to customers today.

"Longevity in this market doesn't happen by chance," added Cooper. "It comes from listening, learning and continually improving. Our history of partnership, quality, and creativity has built a strong foundation. As we look ahead, it's that foundation that opens new possibilities, drives performance and supports continued innovation to help customers achieve consistent results today, while preparing for the challenges of tomorrow."

Learn more at chemcraft.com.

NWFA NAMES MATT CASEY AS TECHNICAL SERVICES OFFICER

The National Wood Flooring Association announced that Matt Casey has been appointed technical services officer. In this role, Casey will provide executive leadership for NWFA's technical standards, publications and industry guidance, ensuring the accuracy, credibility and consistency of the association's technical resources and education programs. He will start March 2, 2026.

"Throughout Matt's 20 years in the wood flooring industry,

he has visited job sites and led schools across the United States and Canada. Those experiences have strengthened his passion for the industry and the leadership he shows in elevating craftsmanship," said Stephanie Owen, president and CEO of NWFA. "We look forward to Matt supporting NWFA members with the technical resources they have come to expect from the association.

Learn more at nwfa.org.

CASTLE CSI 1.5D

Pockets, with screws, in 1.5 seconds



CSI 1.5D cuts 6° low-angle pockets, drills pilot holes, and inserts screws - all in 1.5 seconds! Reduce labor time by half while producing stackable parts that are assembly-ready. Minimal sanding needed. Use with composites, panel, and hard/soft wood.



Optional Air Tables, SideShift Auto Positioner, Hi-Lo Plate, and Offset Work Decks.



www.CastleUSA.com
1-800-282-8338

IWF Booth A10215

Blum's Aventos lift system.



The devil is in the details

Cabinet hardware innovations that enhance function, durability, accessibility, and customer satisfaction

By Ralph Bagnall

Attention to detail is crucial, especially in cabinet-making. I learned this first-hand during a complete remodel of our home's kitchen a few years ago. We got exactly what we wanted: solid beech wood cabinets, a dedicated oven nook, an efficient working triangle, and plenty of storage. However, one drawer didn't turn out quite right.

The drawer in question was a corner one that needed to be shallower than the others. I had used the same brand of slides throughout the kitchen, but due to its unique depth, I opted for a different brand for this single drawer. I thought it wouldn't make much difference, but it did. Although it functioned correctly, it lacked the smoothness of the other slides. On its own, it seemed fine, but

compared to the others, it felt off. Ultimately, I replaced it, proving that details matter.

Hidden components like hinges and slides might go unnoticed in daily use, but they play a crucial role. Fortunately, manufacturers are continuously improving these elements. Staying informed about the latest offerings can help you deliver top-quality results to your clients.

Grass America (grassusa.com) offers a great example of how internal engineering affects day-to-day performance. Its Dynapro undermount slides use a rack-and-pinion gear system that synchronizes the motion of both slides, even though they are connected only through the drawer box. This internal coordination keeps the drawer aligned from front to back and eliminates side-to-side play as it closes.



Salice'as Folder hinge system.

The result? Wide drawers can be pushed shut from any point on the front without racking.

Grass extends its attention to detail with the Nova Pro Scala double-wall steel drawer box system. Available in Silver, Ice, or Stone powder-coated finishes, the system comes in a wide range of sizes and features divider options for customization. It's also simple to build and install.

Blum (blum.com) offers the Space Step, a pull-out platform built into the toe kick. Strong enough to support up to 330 pounds, it helps children reach the sink or allows adults

to access high cabinets. Beneath the step, a hidden drawer adds even more storage. Available in 150 mm (5-7/8") and 250 mm (9-13/16") heights, it does require a taller toe kick, but many clients will appreciate the added functionality.

Blum also features the versatile Aventos lift system for upper cabinets. The lifts can swing up, rise parallel to the cabinet front, open bifold, or function as over/under paired doors. They move effortlessly out of the user's way, making access easier and improving workflow in the kitchen.

SIMPLY BETTER.

EHK360 Trigger Clamps... with a Twist!



Redefining one-handed clamping.

The EHK360 delivers more comfort, control and flexibility, with its 360° rotating handle and 85–300 lbs of clamping force. Available from micro to 36", it clamps or spreads in seconds.

Ask for it at your local retailer.

besseytools.com





The Nova Pro Scala double-wall steel drawer box from Grass.

Hafele (hafele.com) has introduced the MagnaBase Deep Drawer Organizer, which gives homeowners the flexibility to reorganize deep drawers whenever needed. A steel base plate and tall wooden pegs — held in place by strong magnets — create customizable dividers for plates, bowls, and other stackable items. The pegs are simple to reposition: just tilt them to disengage the magnet and place them where needed.

For stylish finishing touches, Hafele's new Deco Collection of pulls and handles offers over 80 unique designs. With options in materials like wood, brass, and bronze, the H25 Deco Collection is perfect for contemporary kitchens.

Salice (salice.com) has introduced Series N hinges specifically for profile or thicker-than-usual doors. Featuring a 40mm hinge cup instead of the typical 35mm, they can be positioned 3–14mm from the door edge and are compatible with Salice's 200 series mounting plates. Available in full overlay, half overlay, or inset versions, they also include integrated, adjustable soft-close action.

To prevent lower cabinet doors from obstructing walkways, Salice's Folder hinge system enables wide doors to open in a bifold configuration while providing full access. Adjustable in six directions, the system works on cabinets between 700mm (27.5") and 1500mm (60") wide, simply by cutting the track to size. Both doors connect to the track for coordi-



Salice's Series N hinge.



VISTA FINISHING[™]
CUSTOM WITHIN REACH



36x36 \$1,453



36x36 \$1,681



36x36 \$2,132

CUSTOM RANGE HOODS

- ✓ Call for FREE Catalog & Price List
- ✓ Stock Sizes Available for Next-Day Shipping
- ✓ Sherwin-Williams Paint Colors and Minwax Stains
- ✓ Order by Phone

5727 Dodge Road, Rome, OH 44085 | (216) 243-8660



Haféle's Deco Collection.

nated, smooth movement.

For clean, minimalist designs with no pulls or handles, the PS23 hinges from **Richelieu** (richelieu.com) open bifold doors with a simple push — no electricity required. Available in black or gray, they support doors up to 55 pounds and accommodate tall panels (up to 94-1/2" or 2400mm). They are part of Richelieu's Cinetto system.









In corner cabinets, accessibility is improved with the Corner Max system — a pair of lazy-Susan-style rotating shelves that do not use a central pole — from **Hardware Resources** (hardwareresources.com). This design leaves the entire shelf open, allowing larger items to be stored across the center. Models come in both a kidney shape (for 90-degree corner cabinets) and a pole-free shape for triangular cabinets, offered in three sizes to match standard cabinet depths. Vertical braces provide the strength needed for heavier items.

For rotating access outside of corner spaces, the Comfort Spin Turntable from **Hettich** (hettich.com) uses an eccentric motion to extend its oval platform beyond the cabinet opening. It can be permanently installed or temporarily mounted using screws, adhesive strips, or suction cups. Part of a broader Spin product line, the units can be used in cabinets, on shelves, or even in refrigerators. Available in Anthracite or Transparent, they can either blend in or stand out as a design feature.

To tackle the challenge of under-sink storage, **Rev-A-Shelf** (rev-a-shelf.com) offers a pull-out cleaning caddy that slides fully out on soft-close slides. The removable caddy can be carried to wherever cleaning is needed, and its polymer shelves and wire dividers



The Logical, Reliable, & Affordable Solution!

 <p>WOOD WORKING</p> 	 <p>CNC & CUSTOM</p> 
 <p>PANEL PROCESS</p> 	 <p>AUTOMATION</p> 

TOP SPECS, TOP VALUE.





USA: +1.626.968.6330
 West: 637 Vineland Ave, La Puente, CA 91746
 East: 331 Jim Cline Rd, Lawndale, NC 28090



Canada: +1.579.420.1794
 803 Rte 202 Ouest, Bedford, QC, Canada J0J 1A0

Email: info@castalymachine.com

Website: www.castalymachine.com





(Clockwise, from top) Hettich's ComfortSpin, Corner Max from Hardware Resources, Häfele's MagnaBase Deep Drawer Organizer, and Undersink Cleaning Caddy from Rev-A-Shelf.





Blum's Space Step features a pull-out step and drawer built into the toe-kick.



keep everything sanitary and organized. When finished, the caddy returns to the base slide and disappears neatly under the sink — a significant improvement over rummaging through cluttered spaces.

In cabinetry, success isn't always about bold design statements. Often, it's the subtle features — smooth slides, intuitive lifts, customizable organizers, and well-engineered hinges — that make a home feel thoughtfully built. Knowing the best hardware options and communicating their value can be the difference between winning a job and losing one. Thoughtful choices in these unseen details ultimately make a space easier and more enjoyable to live in. **W**

RICHELIEU CAPTURES TWO HONORS AT KBIS

Richelieu Hardware won two awards in the Best of KBIS program at the 2026 Kitchen & Bath Industry Show in Orlando, Florida.

The company's ATIPICA decorative hardware collection received silver in the Style Statement – Kitchen category, while the VERTI 840, an electric height-adjustable lift system for upper cabinets, earned gold in the Wellness Trailblazer category.

Best of KBIS is awarded annually at KBIS, North America's largest kitchen and bath design trade show. A panel of industry professionals judges the program, which honors products across seven categories focused on style, innovation, functionality, sustainability and wellness.

BUSYBUSY INTRODUCES VISUAL PROJECT PLANNING

AlignOps BusyBusy has introduced resource planning functionality within its operations module, giving construction teams visual project representations to improve planning and implementation.

According to the company, the digital format allows users to see upcoming work, track committed resources and update plans as schedules change. Unlike spreadsheets and whiteboards, BusyBusy's resource planning features drag-and-drop timeline adjustments. The visual timeline helps users spot conflicts early and adjust plans as conditions change.

AlignOps BusyBusy provides mobile time tracking and GPS-enabled crew management for construction and field service companies. Learn more at alignops.com.

Wharton Esherick Museum explores local roots in anniversary show

By Jennifer Hicks

The Wharton Esherick Museum in Malvern, Pennsylvania, is hosting “Pennsylvania Modern: Regionalism and the Wharton Esherick Studio” at the museum’s visitor center through June 7.

The exhibition marks the 100th anniversary of the Esherick Studio and highlights the local roots of the artist’s 1926 workshop, now a National Historic Landmark for Architecture. The anniversary coincides with the nation’s semiquincentennial celebration.



The Wharton Esherick Studio, as photographed in the 1930s. Built in 1926, the studio is a modern building rooted in rural Pennsylvania.

“The U.S. Semiquincentennial is a moment where many museums are taking a critical look at our relationship with history and national identity,” said Holly Gore, the museum’s director of interpretation and associate curator. “Here at WEM, this event coincides with another milestone, the 100th anniversary of the Wharton Esherick Studio. This exhibition honors both with a reflection on Esherick as he rooted his building in the rich cultural history of Pennsylvania, and the interest in regionalism he shared with his contemporaries.”

In 1926, Esherick (1887-1970) broke ground on a studio that would become the centerpiece of the museum campus. The site on Valley Forge Mountain provided a natural foundation for a structure connected to its surroundings. Local tradesmen raised a stone building grounded in regional geography and architectural tradition. The exhibition presents drawings, photographs, and archival



The entrance to the studio in 1927.



Wharton Esherick, at his studio, in the 1940s.

materials from museum collections that illustrate Esherick’s commitment to place and local influence.

The studio evolved over 40 years. Esherick first constructed a barnlike workspace, later expanding it into a residence with additions in 1940 and 1966. The original 1926 sandstone structure remains visible, reflecting a moment when regional and historic sources connected the building to American modern art.

Esherick’s work appears in the permanent collections of more than 20 museums, including the Metropolitan Museum of Art,

the Whitney Museum of American Art, the Philadelphia Museum of Art, the Museum of Fine Arts, Boston, and the Renwick Gallery.

Learn more at whartonesherickmuseum.org.

DESIGN IN WOOD OPENS IN JUNE

The San Diego Fine Woodworkers Association will host its annual Design in Wood exhibition at the 2026 San Diego County Fair from June 10 through July 5.

The juried show, held annually since 1982, displays qualifying entries to the public while more than 300 volunteers demonstrate woodworking techniques. The exhibition has

grown from 45 pieces in its first year to more than 350 entries from across the United States and internationally. It now awards more than \$25,000 in prizes across 26 classes.

The show also features:

- Wood turning by the Wood Turners Association
- Carving by the San Diego Wood Carvers
- Model building by the San Diego Maritime Museum
- Scroll saw techniques by the Scroll Sawers
- Instrument crafting by luthiers on select days
- Chair caning demonstrations
- Daily docent-led tours

The largest demonstration area is the 19th century cabinet shop, where association members build small oak chairs using only period hand tools. The group crafts 50 chairs annually, donating them to day care centers, schools, hospitals, clinics, shelters and other organizations. More than 1,700 chairs have been donated to date.

The exhibition is co-sponsored by the San Diego County Fair 22nd District Agricultural Association and the San Diego Fine Woodworkers Association.

Learn more at the sdfwa.org. **W**



The People's Choice first, second and third place winners at the 2025 Design in Wood: Dancing Drawers by Scott Baldwin; 1960's Classic Coke Machine by Dennis Chictel, and Spirit of Mexico by Sa Nguansak.

DECORATIVE HARDWARE TO WIN ANY ROOM

High-end craftsmanship by world-renowned designers that level up any space. Our unique cabinet hardware blends innovation with tradition, creating a wide selection of finishes, materials, and design combinations.



TALK TO AN EXPERT
specs@richelieu.com
1-800-619-5446

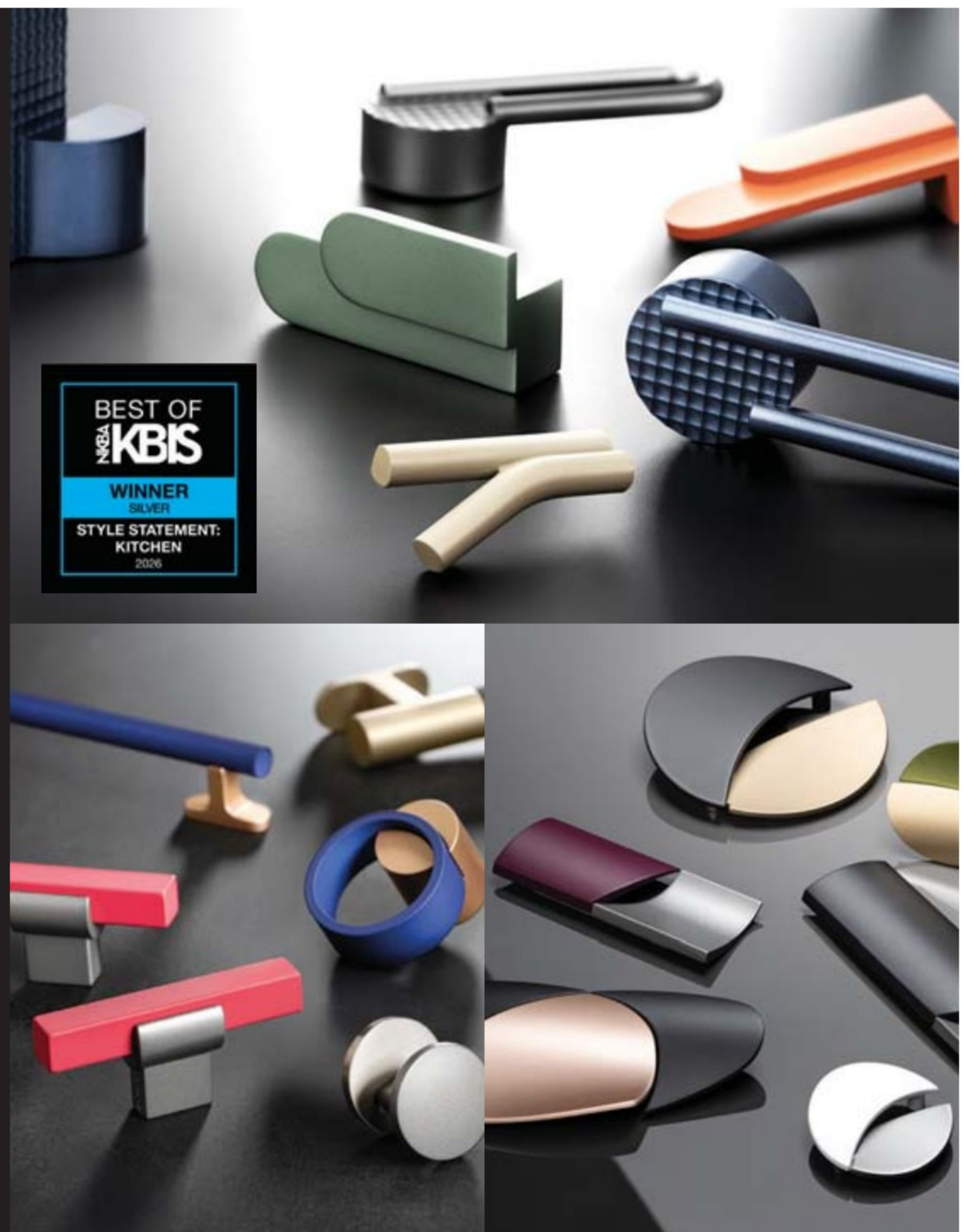



FREE 644-PAGE CATALOG!

The Industry's Leading Sourcebook for Metalworking & Woodworking Machinery
Request yours at grizzly.com/free-catalog

10" 5 HP 240V Cabinet Table Saw

Ultimate cutting efficiency

- 60" Rip capacity
- Extra-large 44" x 27" extension table
- Shop Fox® Classic Fence
- Cast-iron trunnions and internals
- All sealed ball-bearing construction
- Cabinet footprint: 20½" x 20½"
- Shipping weight: ≈ 558 lbs.



MADE IN AN ISO 9001 FACTORY

G1023RLX5 // ONLY \$2795

\$349
FREIGHT
LOWER 48 STATES

8" x 83" 3 HP Jointer

Master the art of seamless joinery

- 36-Indexable-carbide insert helical cutterhead
- Infeed digital height readout
- Parallelogram table adjustment
- Rabbeting table
- Heavy-duty center-mounted fence
- Footprint: 45¾" x 15"
- Shipping weight: ≈ 672 lbs.



MADE IN AN ISO 9001 FACTORY

G0495X // ONLY \$2995

\$349
FREIGHT
LOWER 48 STATES

51" 30 HP 3-Phase Wide-Belt Sander

Achieve consistent thickness on wide panels

- Table height DRO
- Variable-speed feed conveyor
- Pneumatic belt tensioning
- Amp/load meter
- Disc brake
- Footprint: 68" x 20½"
- Shipping weight: ≈ 2866 lbs.



MADE IN AN ISO 9001 FACTORY

G9980 // ONLY \$24,717

\$2299
FREIGHT
LOWER 48 STATES

24" 7½ HP Resaw Bandsaw

Maximize lumber yield and profit

- 24¾" Left cut capacity
- 16" Resaw capacity
- Reinforced rack-and-pinion table tilt mechanism
- Precision-ground cast-iron table with cast-iron trunnion
- Computer-balanced cast-iron wheels
- Footprint: 41½" x 23½"
- Shipping weight: ≈ 948 lbs.



MADE IN AN ISO 9001 FACTORY

SB1123 // ONLY \$4995

\$399
FREIGHT
LOWER 48 STATES

9" x 138½" Oscillating Edge Sander

Exceptional profile sanding

- Variable frequency drive (VFD) for high-torque variable speed
- Digital readouts for sanding belt speed and platen tilt
- Quick-release belt lever
- Graphite-coated platen
- 30–50 Oscillations per minute
- Footprint: 39" x 20"
- Shipping weight: ≈ 811 lbs.



MADE IN AN ISO 9001 FACTORY

SB1127 // ONLY \$5995

\$399
FREIGHT
LOWER 48 STATES

25" 15 HP Helical Cutterhead Planer

Digital presets for rapid production

- 174-indexable-carbide insert helical cutterhead
- Digitally controlled table elevation
- Variable-speed feed: 10–30 FPM
- Table positioning digital readout
- Precision-ground cast-iron extension tables
- Footprint: 47½" x 24½"
- Shipping weight: ≈ 2057 lbs.



MADE IN AN ISO 9001 FACTORY

SB1118 // ONLY \$14,995

\$599
FREIGHT
LOWER 48 STATES

16½" Extreme Series Dovetail Machine

Dovetail joints made easy

- Micro-adjustable spindle head
- Dual pneumatic clamping system
- Four-way dovetail template
- Cast aluminum, spring-loaded carriage
- 24" x 7¾" Precision-ground cast-iron table
- Footprint: 37" x 21¼"
- Shipping weight: ≈ 539 lbs.



G0611X // ONLY \$5050

\$299
FREIGHT
LOWER 48 STATES

10 HP 3-Phase HEPA Cyclone Dust Collector

The standard for industrial air quality

- Ramped inlet maximizes dust flow into the collection drum
- Primary filter: 99.9% at 0.2-2 microns
- Secondary filter: HEPA 99.97% at 0.3 microns
- Blower and barrel rotate 360°
- 55-Gallon collection drum
- Footprint: 96¼" x 52½"
- Shipping weight: ≈ 1555 lbs.



MADE IN AN ISO 9001 FACTORY

G0638HEP // ONLY \$7197

\$499
FREIGHT
LOWER 48 STATES

Horizontal Slot Mortiser

Cut repeatable mortises without jigs

- Westcott-style 2-jaw chuck
- Forward and reverse spindle control
- Longitudinal X- and Y-axis table stops
- Cam-action hold-down clamp
- Smooth ball-bearing table operation
- Footprint: 27½" x 20½"
- Shipping weight: ≈ 315 lbs.



G0846 // ONLY \$1195

\$255
FREIGHT
LOWER 48 STATES

NEW 7½ HP // BAGHOUSE DUST COLLECTOR



36 Fiber Bags with 99.9% @ 0.2–2 Micron Filtration

Three 77-Gallon Quick-Release Drums with Casters

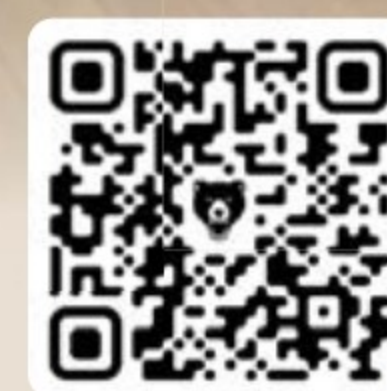

See the Grizzly dust collector in action!

G0406

COMPETITIVE PRICE

\$9,995

\$399
FREIGHT (lower 48 states)

HIGH-CAPACITY DUST COLLECTION

The G0406 eliminates poor air quality and dust buildup in busy production shops. Designed to handle multiple large machines simultaneously, it replaces several smaller units with a single high-efficiency system. Massive capacity and an automatic shutoff feature prevent messy overflows and streamline maintenance, letting your team focus on their projects rather than emptying collection drums.

Specifications:

- Required power: 220V, 3-phase, 50A
- Airflow performance: 5000 CFM @ 4.2 in. SP
- Filtration rating: 99.9% @ 0.2-2 Microns
- Filter surface area: 311 sq. ft.
- Sound rating: 80 dB
- Filter bags (36): 6⁵/₈" D x 59¹³/₁₆" L
- Collection drum bags (3): 37¹³/₁₆" Dia. x 53¹/₈" L
- Footprint: 120¹/₂" x 42"
- Overall size: 121" W x 42" D x 104" H
- Approximate shipping weight: 1391 lbs.

grizzly.com

800-523-4777
#GRIZZLYTOOLS



FINANCING AVAILABLE

Please visit grizzly.com for up-to-date pricing.

Due to rapidly changing market conditions, our advertised prices may be changed at any time without prior notice.

WARNING! †: Cancer & Reproductive Harm

Some products we sell can expose you to chemicals known to the State of California to cause cancer and/or birth defects or other reproductive harm. For more information go to www.P65Warnings.ca.gov.



Owner Don Burkard.

CATERING TO ALL

Burkard Custom Cabinets grows through referrals, technology investment

By Jennifer Hicks

Don Burkard, owner of Burkard Custom Cabinets in Glenmoore, Pennsylvania, has built his business on one principle: serve everyone well. Whether a client invests in a full kitchen remodel or a modest cabinetry refresh, Burkard approaches each project with equal care and attention to detail.

Operating with six employees, the company completes between 60 to 90 projects annually throughout Chester County and the surrounding region. From kitchens and built-ins to trim work and custom furniture, the shop handles diverse residential projects. Burkard credits his longevity and steady workflow to one decision — staying open to all types of work.

“Everyone has a unique style,” he says. “We’re not strictly high-end kitchens. We’ll work with all price points. Obviously, it has to make sense for us, but I try not to discriminate just because it’s not a \$112,000 kitchen. I one hundred percent feel like that’s what has kept us busy for so long.”

Burkard has never relied heavily on advertising. Nearly all projects come through referrals and repeat clients.

“I can trace almost all of our customers back through who recommended them or whether they were a repeat customer. That’s been great because it’s one less thing I’ve had to worry about. The work just kept coming in.”

AN UNEXPECTED PATH

Although Burkard always enjoyed building things, running a cabinetry business wasn’t his original plan. He grew up in Downingtown, Pennsylvania, attending Downingtown High School, and studied carpentry at the Technical College High School Pickering Campus. After graduation, he worked in several local shops, developing his skills.

His long-term goal was different. Burkard developed an interest in community and regional planning and attend-

ed Delaware County Community College before earning his bachelor’s degree from Temple University.

“My goal was to get a job at a large planning firm or large developer and change the way neighborhoods were designed and laid out,” he says.

After college, he struggled to find stable employment in his field. The jobs he secured were short-lived, often ending in layoffs within months. During those periods, family and friends frequently asked him to build furniture or help with home projects.

“When I was laid off, people would ask me to build this or that,” he recalls. “It just kept happening. Eventually it got to the point where I realized I might as well go out on my own.”

In 2009, Burkard officially launched his business.

FROM GARAGE TO CUSTOM FACILITY

Like many small-shop owners, Burkard’s early years involved creative use of limited space. He initially operated from his parents’ garage in Downingtown. As demand grew, he and his wife purchased a house in Thorndale with plans to renovate and flip it. Instead, the property became a makeshift workshop.

“I gutted the house and rebuilt it, but I was so busy I needed more space. So I ended up using the first floor as half a shop.”

The back bedroom became a spray booth. The dining room served as a staging area. A table saw occupied the family room.

Six years ago, Burkard constructed a dedicated shop next to his home on 2.5 acres. Completed in 2020, the building features a 2,000-sq.-ft. footprint with 3,200 sq. Ft. of total usable space, including a mezzanine for offices.

When the facility opened, the crew consisted of Burkard and two employees. Today, the company em-



Burkhard with employee Logan Edwards.

plys six people: two in the office, three in the shop, and Burkhard splitting time between production and administration.

FOCUSED SERVICE AREA, FLEXIBLE MINDSET

Burkhard typically serves clients within an hour and a half drive. Key areas include Downingtown, particularly within the Downingtown Area School District, and Kennett Square, though the team travels farther when projects merit it.

“We don’t like to go too far, but we will. It depends on the job. If it’s worth it and it’s going to be fun, sure.”

The company focuses almost exclusively on residential work. Over the years, Burkhard estimates completing only about 20 commercial jobs. Kitchens account for 60 to 70 percent of the workload, with the remainder divided among built-ins, vanities, furniture and specialty trim projects.

The shop once handled bathrooms and basement renovations, but Burkhard narrowed the scope.

“We used to do more full remodeling. Now we’re really focused on cabinetry.”

That specialization has helped maintain consistency. While business ebbs and flows, the overall trajectory remains steady.

“There have been slow periods. Earlier in 2025 it was quiet for a bit. But we’re solid now and booked out.”

AN ECLECTIC PORTFOLIO

True to Burkhard’s philosophy, the shop’s portfolio varies widely.

“We’re a pretty eclectic shop. We don’t do the same thing over and over.”

Recent projects include a kitchen refresh featuring stained maple cabinetry, dark blue painted built-ins, and refinished cherry Adirondack chairs for a neighbor. Each reflects different aesthetics, and Burkhard encourages clients to embrace their personal tastes.

However, certain trends persist.

“We still see a lot of painted Shaker cabinets. That style has been king for

It’s Not Just a Router, it’s a PantoRouter.®

A professional-grade tool for every craftsman.

Precision and speed



Minimal setup without complicated jigs



- Set up without measuring and marking
- Faster than CNC for many joinery operations
- Precise fit using patented tapered templates
- Change bits without removing the router from mounts
- Two levers control all three axes, X, Y, and Z



Dedicated to Joinery.

PantoRouter.com

(877) 333-7150

info@pantorouter.com





Burkard and the shop's intern, Akia.

a long time, and it's still strong. But we're starting to see more walnut and white oak with clear finishes."

As a turnkey operation, the company handles design, fabrication, finishing and installation in-house. An additional revenue stream has developed through partnerships with local painters who specialize in cabinet refinishing. The painter sells a kitchen refresh, and Burkard's team fabricates new doors. The painter sprays the cabinets and doors, and Burkard returns for final installation.

"That's been a great relationship over the last couple of years," he says.

A GAME-CHANGING INVESTMENT

Two years ago, Burkard purchased a ShopSabre IS 408 CNC machine, an investment he calls transformative.

"It opened up a whole new world," he says.

He recalls fabricating a simple 36" x 42" vanity before acquiring the CNC — a unit that required several hours of cutting, drilling and assembly preparation. Shortly after installing the machine, he received an order for an identical vanity.

"It took 13 minutes. It was insane. It's been a complete game changer. I don't think about the build process the same way anymore."

The CNC dramatically improved efficiency,

 Made in the USA



Tired of Emptying Dust Drums?

Upgrade to an Air Lock Dust Collection System

- Expanded waste container options
- Move the dust where you want it



10HP Direct Drive
with air lock shown



800.732.4065

LEARN MORE!
oneida-air.com



Josh Hohman, a long-time employee, works in the shop, while Scott Yankovich and Amie Kinderman take care of the office.

particularly in door production and sheet goods processing. It also sparked interest in technology and optimization. Burkard now evaluates every process through the lens of efficiency.

“The CNC changed how we operate. It pushed my thought process toward optimizing everything.”

Space constraints limit additional machinery, but Burkard believes one well-chosen piece of equipment can significantly increase output. He has started experimenting with emerging technologies, including a 3D printer.

Initially, the printer produced painter’s pyramids — small stands used in spray booths — at a fraction of retail cost. But the experiment expanded his thinking.

“I’ve started looking into 3D scanning door profiles, digitizing them, and running them through the CNC. We could print sample doors, prototype ideas, or even think about outdoor cabinetry components in the future.”

Burkard has also incorporated artificial intelligence into operations. He spends considerable time nesting cabinet parts and doors on plywood sheets to minimize waste. Recently, he started exploring AI-assisted nesting to streamline the process.

“I spend an insane amount of time trying to use as much material as possible with as little waste as possible.

WHAT’S IN THE SHOP?

Shop Sabre IS 408 CNC • SawStop ICS 51230 cabinet saw • Grizzly Industrail GO774 edge bander and G1033X planer • Laguna LT14BX band saw • Kreg DK1100FE pocket hole machine G1033X planer • Kremlin Rexson airless air-assisted pumps and sprayguns

So, I’ve been working with AI and feeding it information to help optimize layouts.”

Despite investments in advanced machinery, Burkard’s business remains built on relationships. The referral-based model has sustained the company for 15 years, and Burkard remains committed to serving diverse clients. By refusing to limit the company to luxury kitchens or narrow aesthetic niches, he has created a steady pipeline of varied work. From modest updates to full custom builds, each project builds the company’s community reputation.

“Everyone has their own style. Our job is to bring that to life.”

Learn more at burkardcustomcabinets.com. **W**



Kreg's new dowel joinery jig offers precise, repeatable layout (A) and depth control (B), plus a choice of dowel diameters.

Beyond dovetails

Today's joinery embraces engineered solutions

By John English

For centuries, classic joinery relied on dovetails, dowels and mortises. Today, joints are just as likely to use metal or plastic engineered connectors, non-wood dowels, or biscuits.

While traditional methods have merit — and ways exist to speed up those joints — modern connectors offer compelling advantages.

BISCUITS AND DOWELS

Woodworkers familiar with biscuit joiners can easily upgrade to the **Lamello P-System** (csaw.com/lamello). The blade on the Zeta P2 profile biscuit joiner cuts the normal half-football-shaped recess, then moves up and down to create a T-slot along the rim. Lamello makes several types of biscuits with matching T-shaped ridges along their edges that slide into place from either end. This anchors connectors in two planes for exceptional strength.

The Tenso connector snaps together for 30 pounds of clamping pressure, while the Clamex connector uses a

hex key and cam system to increase joint strength to 200 pounds. Clamex also enables easy disconnection of unglued joints for knock-down applications. The company offers various models for specific tasks, such as shallow cuts for installing horizontal shelves against thin vertical cabinet sides. The Zeta P2 tool also functions as a standard biscuit joiner.

Plastic dowels remain popular. The 8mm diameter Super-Grip dowel from **Bainbridge Mfg.** (bainbridgemfg.com) measures 7.5mm x 8.6mm with a slightly oval shape. Channels along each narrow face, combined with the oval shape, allow adhesive to spread effectively.

Richelieu Hardware (richelieu.com) offers the MP9835 ribbed plastic dowel with two advantages over traditional wood: humidity doesn't affect it, and it requires no glue, according to the company. The supplier carries connectors from cam-and-dowel to the OVVO click-together system, plus Domino connectors from Festool. Its Flush Cam face-mounted connector, designed for flat-packs, features



There are more than 10,000 Lamello Zeta P2s in use across the U.S., providing clever casework and face frame connections.

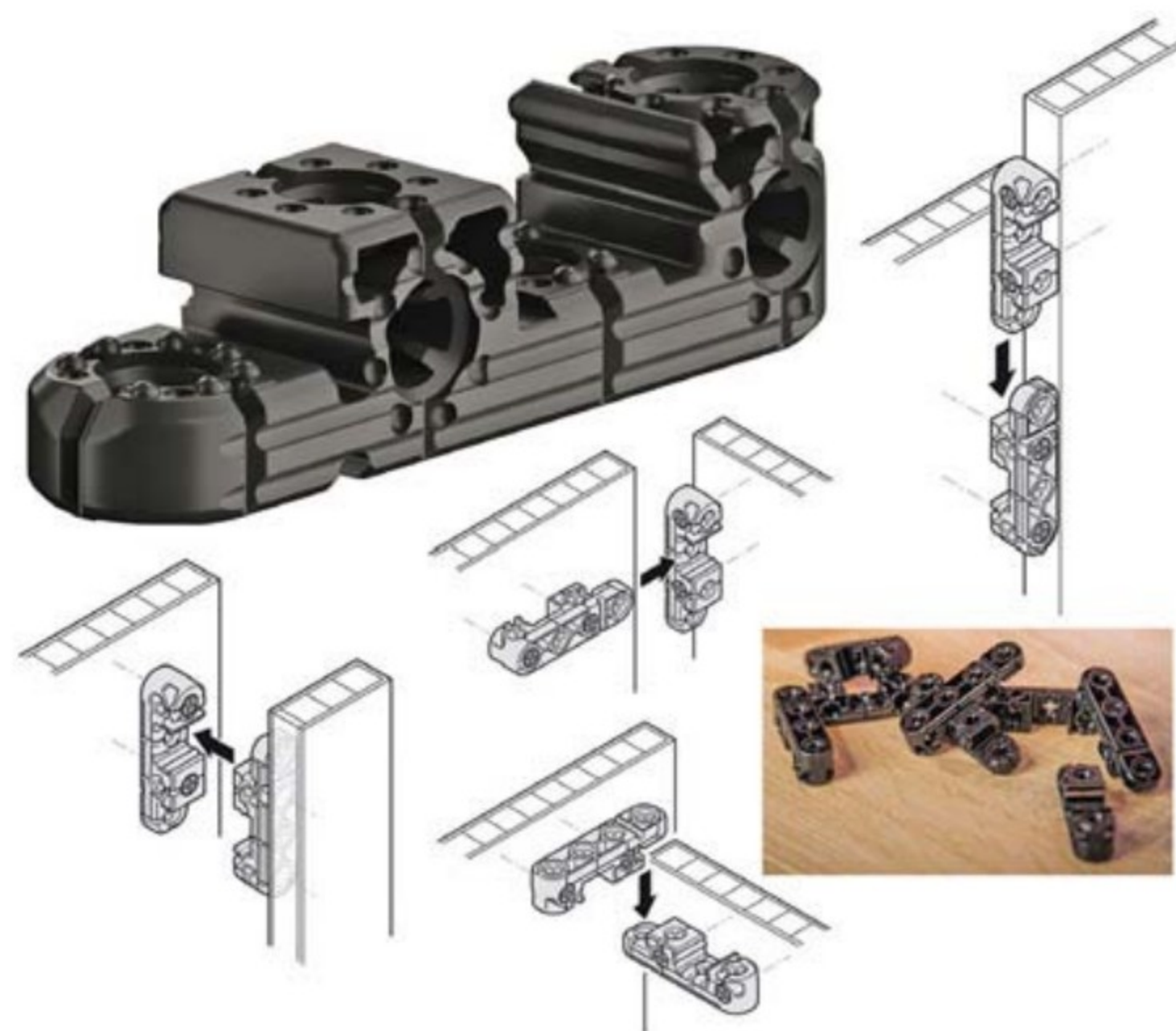

Shown are just some of the ways that the new Ixconnect Universal Connector 1664 from Häfele America can be used.



In its large catalog of connectors, Richelieu offers glue-free MP9835 plastic dowels and a cam-and-dowel joinery system.

a low-profile housing that sits flush with panel surfaces to prevent transport damage. The cams pair with all System 6 Screw-In and Quickfit dowels.

Through partnerships with CAD publishers including Microvellum's AutoCAD-based platform and EFICAD's Swood, **Lockdowel** (lockdowel.com) integrates its invisible dowel connectors into shop drawings. This hardware — a single plastic or metal piece using a keyhole slot locking mechanism — helps woodshops reduce time building tool-free, ready-to-assemble cabinets. The software automatically creates 3D components with appropriate machining for Lockdowel fasteners.

Kreg Tool's new Dowel Jig Kits (kregtool.com) reinvent wooden dowel joinery. The two-part jig features a base for alignment and interchangeable inserts that guide drill bits. The base uses visible pencil lines, alignment tabs and pins to make marking and clamping precise, fast, and repeatable. Inserts accommodate various dowel diameters based on material thickness or required strength. The bottom line is fast, clean, consistent dowel joinery without much measuring or guesswork.

SCREWS, NAILS AND STAPLES

Quickscrews International (quickscrews.com) engineered its cabinet assembly screws to drive into MDF

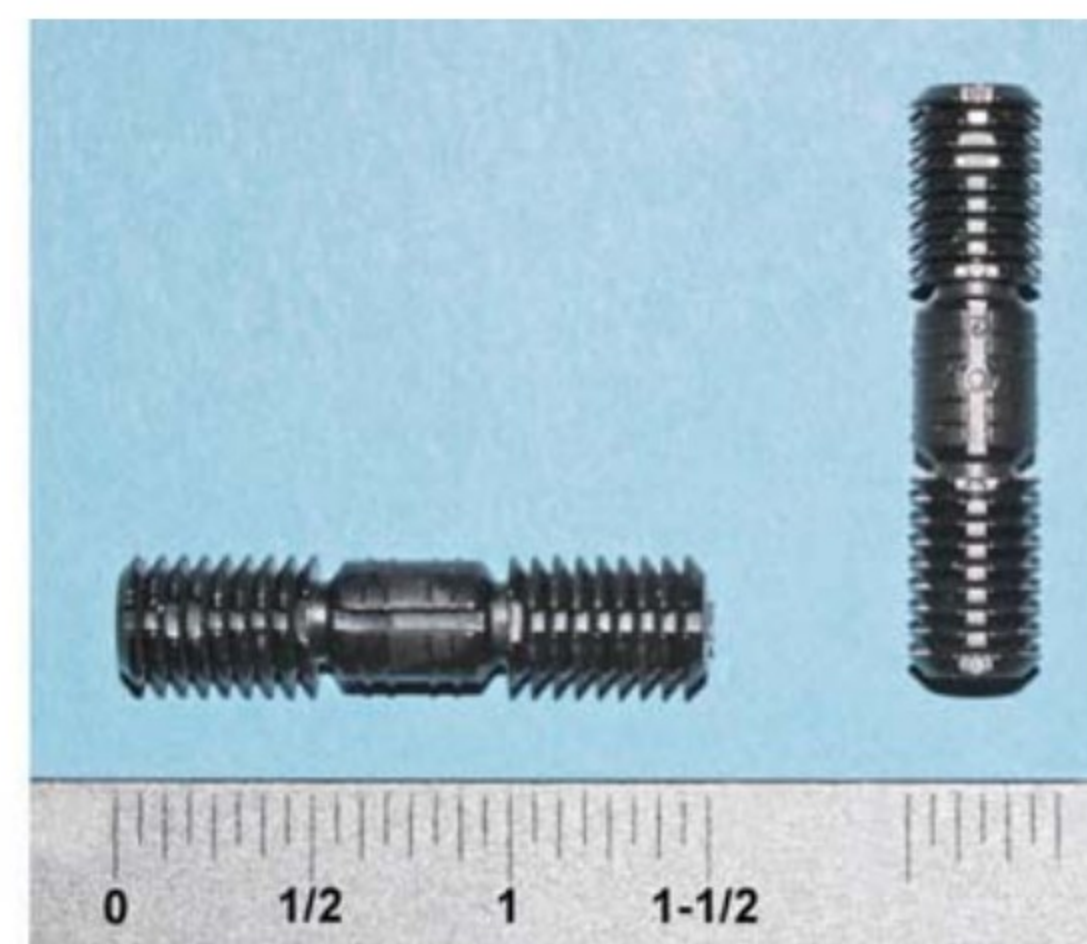
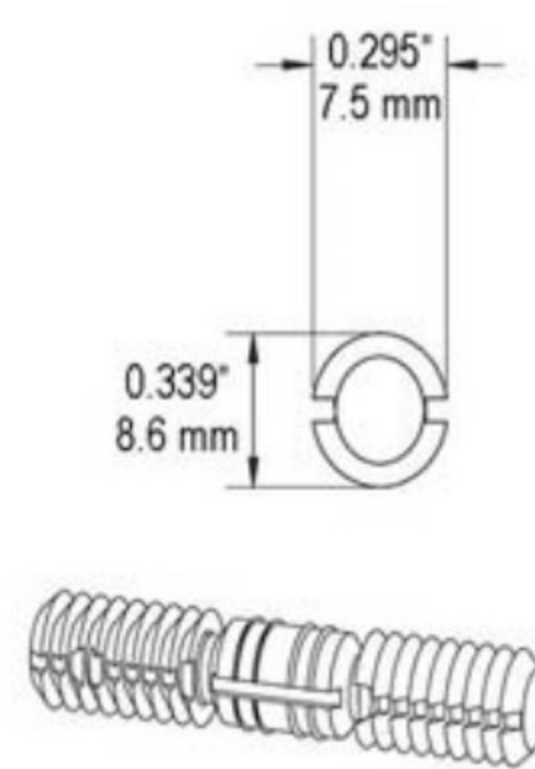

The model 1996 Super-Grip plastic dowel from Bainbridge has a slightly oval shape and a channel for glue along its length.

and plywood without pre-drilling, ideal for shops lacking CNCs or boring equipment. They tighten joints and speed casework construction by requiring less prep and reduced clamping time.

Kyocera Senco Industrial Tools (senco.com) offers two finish nailers for case building, trim and face frame work. The TN41P1P 16-gauge finish nailer features oil-free design and dry-firing lockout. Users can instantly switch between contact or sequential firing modes, and it has a quick-clear latch for jams or misfeeds. For face frame joinery, tool-free depth adjustment allows flush or countersunk setting. The lightweight aluminum tool drives nails from 1-1/4" to 2-1/2". For jobsite work and tight cor-

Unleash Your Sanding Potential

Discover Cutting-Edge Woodworking with the PS-300 Automatic Molding Sander

Elevate your woodworking projects with the PS-300 Automatic Molding Sander, expertly crafted to provide a thorough and uniform finish for sanding and sealer-sanding work pieces like moldings, trim, and flooring—all at a budget-friendly price.

Key Features

- **Width:** 12 inches / **Height:** 6 inches
- **Conveyor:** Variable Speed
- **Brushes:** Variable Speed
- **Power Supply:** 230v, 3 Phase



877-785-0274



astalner@gibbsgroupna.com



www.gibbsgroupna.com



Where nailing is an option, Senco offers the new 16-gauge TN41P1P and the angled 15-gauge TN51P1P finish nailers.



A new line of cabinet assembly screws from QuickScrews (the 2" version is shown) are self-drilling and countersinking.



For traditional mortise and tenon joinery, Grizzly Industrial's G0645 benchtop mortiser can handle parts up to 6" thick.

ners, the company's TN51P1P 15-gauge angled tool offers the same features, including a swivel air plug and 360-degree directable exhaust.

The 9032 wire stapler from **GreX USA** (grexusa.com) suits cabinetmakers' needs. It shoots 18-gauge, 1/4" crown staples from 3/8" to 1-1/4" long. Its long nose accesses tight spots and difficult angles. The lightweight tool penetrates solid hardwoods, features quick-release nose cover and easy drop-in loading. Grex plans to release a new 1/4" high-capacity pneumatic stapler holding 200 staples with integrated lights, plus a cordless version.

UPDATED TRADITIONS

Woodworkers exploring traditional joint construction may find answers in Graham Blackburn's book, "Fundamentals of Furnituremaking," available from **Klingspor's Woodworking Shop** (woodworkingshop.com). Detailed chapters cover miters, dovetails, mortise-and-tenons,

splayed joinery, and drawer building. The book updates his 1977 master class in joinery.

The **PantoRouter** (pantorouter.com) suits commercial joinery in smaller shops without CNCs or where the CNC is otherwise occupied. It uses a guide bearing to follow a template that moves the router bit as it cuts a pattern identical in shape to the template but half the size. Using patented templates and a combination of guide bearings and router bits, it cuts both sides of a joint — mortise and tenon, or pin and tails — with a single template and setup. It also makes box joints, sliding dovetails, angled and compound angled mortise and tenons, or unusual shapes and multiple mortise and tenon combinations. The operator uses two levers to control all three axes for precise, repeatable joinery.

The new Ixconnect Universal Connector 16/64 from **Häfele America** (hafele.com) is a single fitting that solves several joinery challenges. It combines a surprising number of different furniture connector solutions into one prod-



Equipped here with a Bosch motor, the PantoRouter is a user-friendly solution for high quality, precise joinery in solid wood.

uct thanks to some complex, well-thought-out engineering. The small (16 x 16 x 64mm) polycarbonate connector can be clipped together, pushed in and mounted at different angles. Its versatility helps reduce hardware inventory.

Joinery extends beyond connectors. Keeping machined assemblies such as five-part doors flat and square during glue-ups can be challenging. **JLT** (jamestaylor.com) offers face frame tables, edge gluing and lamination clamps, stile and rail or mitered door squaring aids, drawer assembly solutions and glue applicators.

Castle USA (castleusa.com) makes assembly tables and supplies solutions that align parts for pocket screw joinery. Castle drills pockets at 6 degrees versus the industry standard 15 degrees. The company says this creates stronger, more stable joints while minimizing or eliminating joint shift, where parts move out of alignment as screws are driven. This can reduce sanding and finishing time.

Grizzly Industrial (grizzly.com) carries the G0645, a 1/2-

hp benchtop cast iron mortising machine for square and rectangular mortises. It features a rack-and-pinion fence and head control, a six-position handle and an included riser block adding 1-1/4 inches of stroke to the dovetail profile column for parts up to 6 inches thick. A pneumatic return strut eases the step-and-repeat cycle for multiple mortises. The worktable measures 10-1/2" x 12-1/4". A drill chuck simplifies chisel changes, and the machine includes four chisels: 1/4, 5/16, 3/8 and 1/2 inch.

Hoffmann Machine Co. (hoffmann-usa.com) puts a different spin on another traditional joint — the dovetail. The manufacturer supplies free-floating plastic and wood dovetail-shaped strips and keys, plus machines that cut their recesses. Keys come in various colors to strengthen miters, butts, compound miters and end-to-end junctions. Hoffmann's current top seller is the W-2, a 5/8"-wide dovetail key for parts 3/4" thick or more. Five different dovetail keys are available. **W**



After parts have been cut and milled, JTL offers a range of clamping solutions that can speed up the assembly phase of joinery.

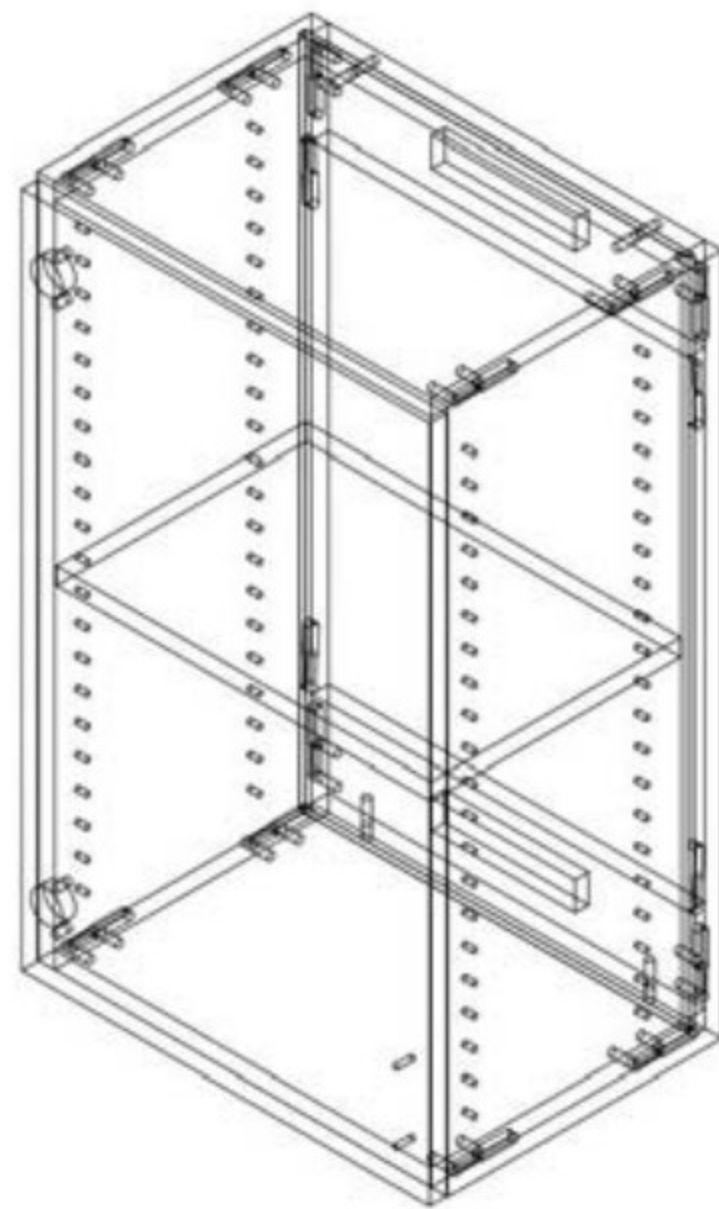
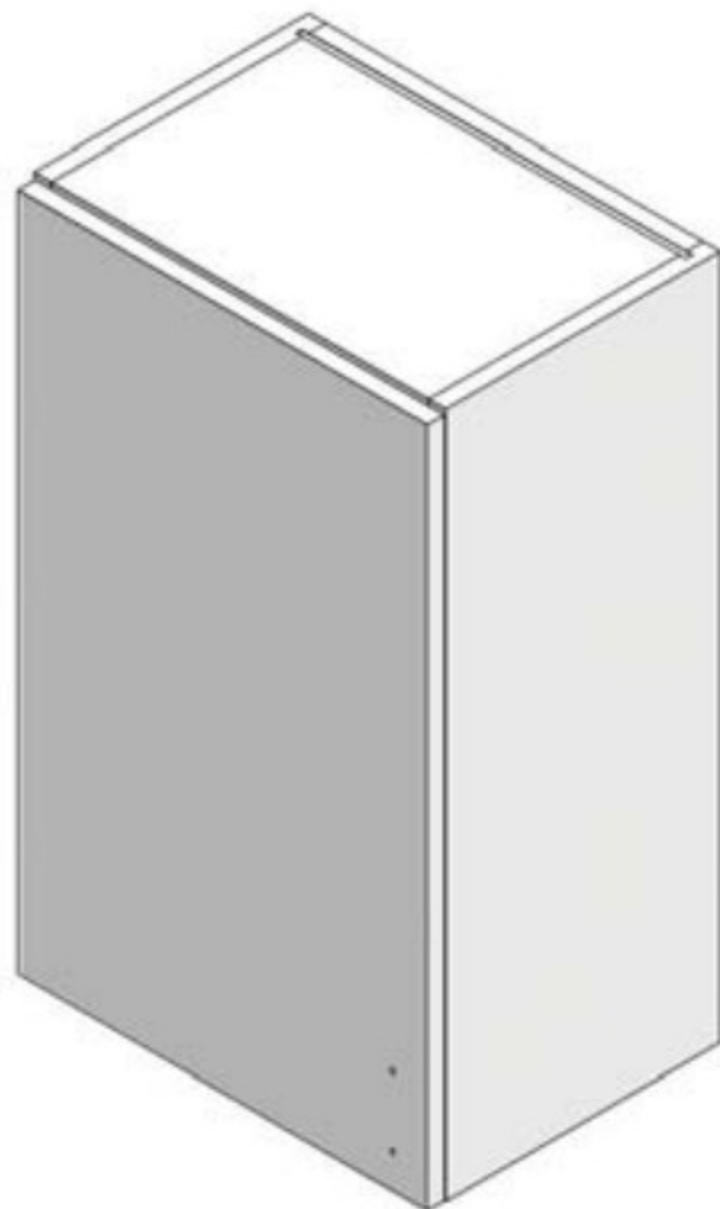

Barbed Channel Lock (Plastic)
Qty: 12



Double-Headed Channel Lock (Metal)
Qty: 4



8mm x 40mm Spring Pin
Qty: 4



Lockdowel connectors can be incorporated in a CAD library so the drawings show the locations and quantities of hardware.

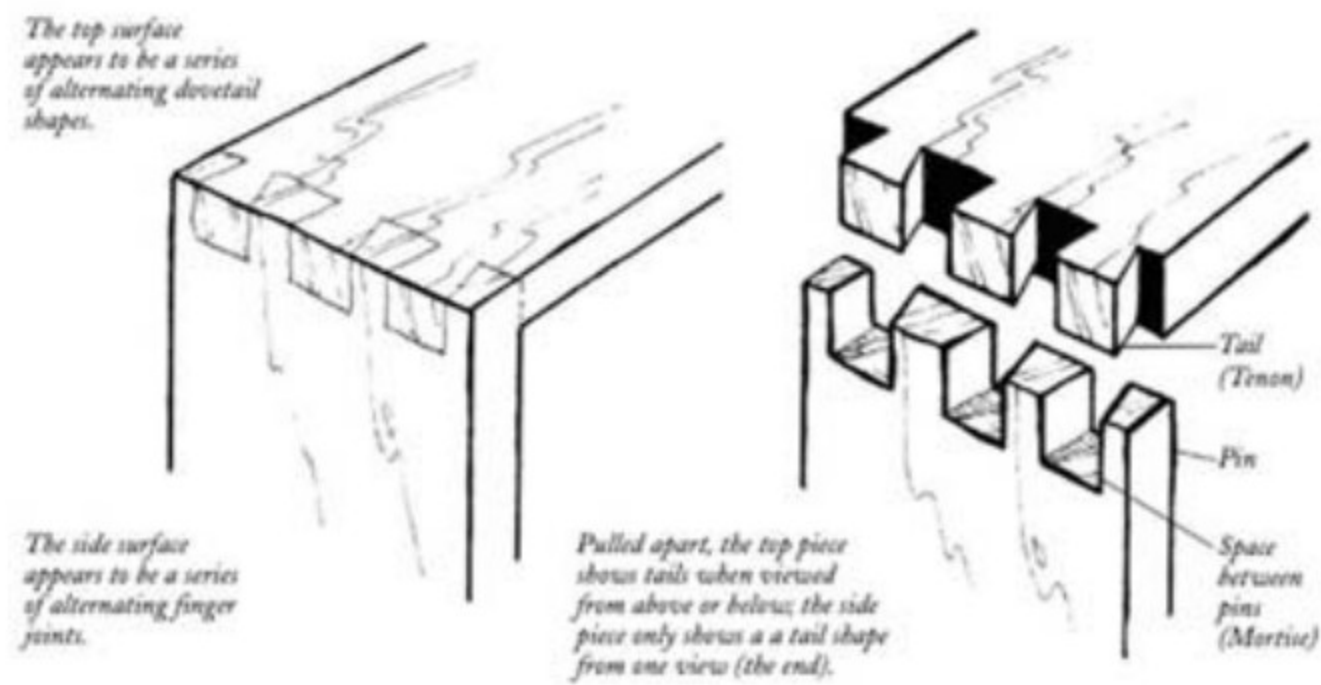
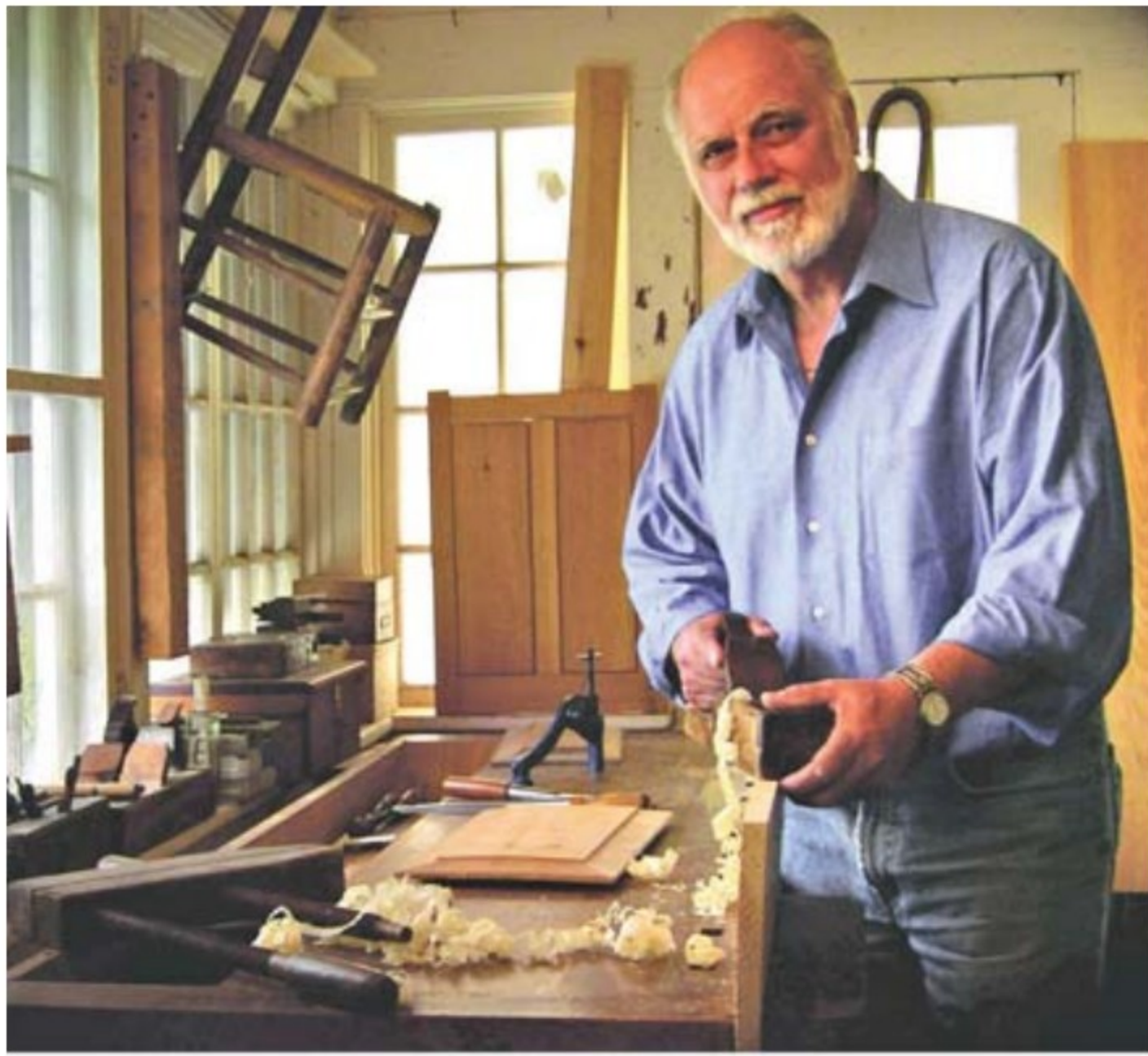

Graham Blackburn's book on traditional joinery methods and options is available from Klingspor's Woodworking Shop.

OTHER RESOURCES

There are many more options for commercial joinery methods worth investigating on your own.

Following is an alphabetical list to get you going:

- | | |
|----------------------------|--|
| Arrow Fastener Co. | arrowtoolgroup.com |
| ASMC Industrial | asmc.net |
| BeA Fasteners USA | beagroup.com |
| Cabinotch | cabinotch.us |
| Deerwood Fasteners | panamericanscrew.com |
| Doucet Machineries | doucetinc.com |
| Excel Dowel | exceldowel.com |
| FastCap | fastcap.com |
| FastenLink | fastenlink.com |
| Festool Domino | festoolusa.com |
| Fastenry | fastenry.com |
| McFeelys | mcfelys.com |
| Omer USA | omertools.com |
| Outwater Industries | outwater.com |
| OVVO | ovvotech.com |
| Screw Products | screw-products.com |
| Shaper Origin CNC | shapertools.com |
| SmartBench CNC | yetitool.com |
| Versidex | versidex.com |
| Voorwood | voorwood.com |

New England Drawer

3 DAY * Turnaround on beautiful Dovetail Drawers

- The gold standard of Dovetail Drawers
- Fast turnaround times
- Competitive pricing
- 2 Drawer grades available
- High customer satisfaction
- Undermount slides available
- USA Made
- Ships nation wide

ORDERS & INFORMATION:

603-926-2588 | 866-391-3863
www.newenglanddrawer.com

*Restrictions apply



Made by
cabinetmakers
 for cabinetmakers



An oil finish from Livos.

The evolution of wood protection

From solvent-heavy lacquers to water-based UV systems, finishing technology adapts to stricter regulations and changing customer demands

By Ralph Bagnall

Wood finishing has evolved dramatically over the past 40 years, with the most significant shift being the transition from traditional solvent-based finishes to low-VOC alternatives.

The Environmental Protection Agency defines volatile organic compounds as “compounds that have a high vapor pressure and low water solubility. Many VOCs are human-made chemicals that are used and produced in the manufacture of paints, pharmaceuticals, and refrigerants.” VOCs can harm humans and animals and commonly contaminate groundwater.

California has implemented some of the nation’s strictest regulations on traditional finishing products, citing safety and environmental concerns. New technologies

have emerged to meet these standards while offering expanded features and capabilities.

The transition to water-based solvents has driven much of this progress. Over the last 30 years, water-based grain fillers, stains, and topcoats have improved dramatically. Companies like **ECOS Paints** (ecospaints.net) offer non-toxic, low-VOC finishes across a wide product line.

Options in water-based finishes continue expanding for specialized applications. The EVO line from **Gemini Coatings** (geminiindustriesinc.com) targets commercial cabinetry for healthcare facilities with an antimicrobial additive that the manufacturer says never requires reapplication. **Aqua Coat** (aquacoat.com) has introduced its Instrument Lacquer in high gloss and satin finishes spe-

cifically for luthiers, featuring what the company calls concert-grade durability.

MATCHING PRODUCTS TO PURPOSE

Manufacturers have also broadened their low-VOC product ranges. For example, **M. L. Campbell** (mlcampbell.com) distributes Italy's Sayerlack finishes in both water-based and polyurethane formulations, enabling shops to match products to specific project requirements.

Pre-catalyzed finishes have also transitioned to low-VOC formulations. Multiple manufacturers now offer these products, which provide near-factory finish quality for individual shops while requiring less extensive personal protective equipment.

Milesi Wood Coatings (milesi.com) offers marine finishes that comply with International Maritime Organization regulations requiring fire-resistant coatings for ship interiors.

The Selva Pro 2K Polyurethane System from **Chemcraft** (chemcraft.com) streamlines mixing, training, and inventory with a focused selection of hardeners and tintable polyurethane and acrylic finishes suited for durable, high-quality wood protection. The range includes Chiaro polyurethane clear finish for robust wear and moisture protection, Bianco pigmented polyurethane for full color choice, and the Acrilico acrylic formulation to enhance high quality wood grains. Arilico finishes are also tintable for unlimited color choices.

UV-cured finishes have also shifted to water-based formulations. Early UV-cured products required full-body protective equipment due to toxicity when wet. Current water-based versions still require PPE, primarily for UV light protection rather than vapor exposure. These finishes cure in seconds under UV light after application. **Sherwin Williams** (sherwin-williams.com) offers UV-curable products ranging from paints to stains, fillers



Produced with ECOS Paints.

and topcoats for various applications, including furniture, cabinetry, flooring, and decking.

THE ENDURING APPEAL OF OIL

Oil finishes remain viable alternatives, using modern formulations alongside newer technologies. Oil finishes can be renewed with minimal preparation, eliminating the need to strip old finishes during maintenance.

Livos-US (livos-us.com) offers engineered oil products for interior and exterior surfaces, including formulations safe for toys and food-contact surfaces like countertops and cutting boards. The company also produces oil-wax blends for long-term finish maintenance.

Rubio Monocoat (rubiomonocoatusa.com) specializes in single-coat oil finishes that bond with wood surfaces.



Cabinets with a Sayerlack finish.

An application of Rubio Monocoat.



Marine finish produced with Milesi Wood Coatings.





The company offers interior and exterior formulations, plus preapplication treatments, cleaners and fillers, along with staining options including pre-aging treatments.

The growing demand for natural wood cutting boards, charcuterie boards and serving trays has prompted development of specialty finishing oils. **Odie's Oil** (odiesoil.com), **Howard Products** (howardproducts.com) and **Marshall's Wood Butter** (marshallswoodbutter.com) offer food-safe finishes that manufacturers can use during production and consumers can apply for maintenance.



POWDER COATING AND EPOXY

Epoxy coatings continue advancing alongside other finishing technologies. Epoxies encompass a broad category of chemicals that manufacturers can formulate for specific applications, including adhesives with customized working times, chemical-resistant topcoats, and clear or tinted sealants for electronics and casting applications.

Woodworkers commonly use thick bar-top epoxy coatings and marine-grade formulations, while casting resins offer expanded possibilities for finishing and decorative



VEXOR

Custom Woodworking Tools
Denver, CO

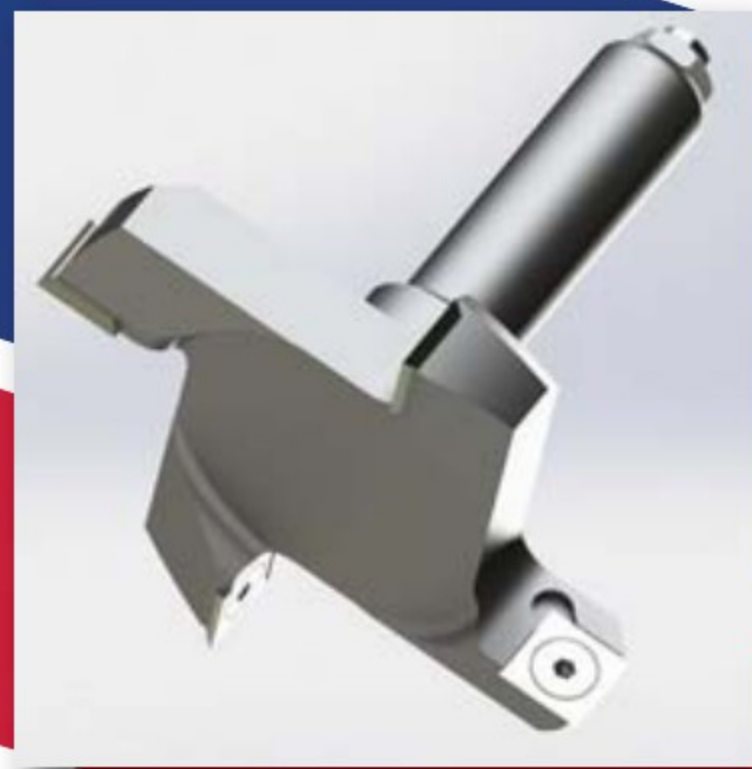

Router bits, shaper cutters,
insert tools, profile knives and
more for the woodworking industry.
Family owned and operated for over 40 years

Vexorcwt.com | Toll Free: 877.879.8906



Chemcraft's Selva Pro finish.

applications. Some establishments feature wood slab tables with decorative elements like pebbles embedded in cast epoxy to simulate stream beds. When resin coats entire table surfaces, no additional finishing is required. Thick resin surfaces can be sanded, buffed and polished repeatedly to remove scratches and damage.

Thick resin surfaces can be sanded, buffed and polished repeatedly to remove scratches and damage.

System Three (systemthree.com) manufactures epoxy formulations for deep casting, bar tops, flooring and boatbuilding applications. Epoxies also serve restoration and repair functions, reinforcing deteriorated wood, replacing missing sections, and protecting water-contact surfaces.

Powder coating represents another finishing option beyond liquid applications. While powder coating of metal components is well established, manufacturers increasingly apply the technology to MDF.

The powder coating process applies an electrostatic charge to the substrate, then sprays powder electrostatically onto the surface. Curing in an oven melts and fuses the particles into a durable coating. Companies including **Tiger Coatings** (tiger-coatings.com) and **Decoral America** (decoralamerica.com) supply coating powders, though the space and capital requirements for ovens and cooling areas typically limit in-house operations to larger manufacturers. Regional vendors such as **DVUV** (dvuv.com) in Cleveland, offer contract powder coating services, making the technology accessible without major capital investment.

Modern finishes range from traditional oil applications maintained over time to powder-coated surfaces engineered for high-traffic commercial use. Healthcare facilities may require antimicrobial sealed finishes, while children's furniture demands nontoxic formulations safe for direct contact. Product selection depends on customer requirements, production capabilities, and available equipment.

Finishing products continue evolving across multiple categories. Industry professionals who don't work with finishes daily may miss significant innovations in formulation and application technologies.

Trade shows including the Association of Woodworking & Furnishings Suppliers' Fair and the International Woodworking Fair provide opportunities to explore new developments in finishing technology. **W**



Powder coating from Tiger Coatings.



TASK LIGHTING & POWER

has redesigned its Ultra-Thin Puck Light to speed up installation. The updated fixture, from the Hardware Resources subsidiary, now features a lens attached to the fixture body rather than the trim piece. This change allows installers to snap the trim into place more quickly, according to the company. The Ultra-Thin Puck Light measures 5/16" thick and mounts to surfaces with short screws hidden by the trim plate. The fixture is designed for tight spaces such as shelving and nooks. Learn more at tasklighting.com.

METABO HPT

has introduced the Tracker Pro (Model 383312M), a tracking device for monitoring tools, equipment and other items on construction sites. The device works with Apple Find My and Google Find Hub networks, allowing users to locate tagged items through their smartphones. The Tracker Pro sends alerts when users move too far from a tracked item and can be attached to tools using adhesive, ties, or screws. Learn more at metabo-hpt.com.

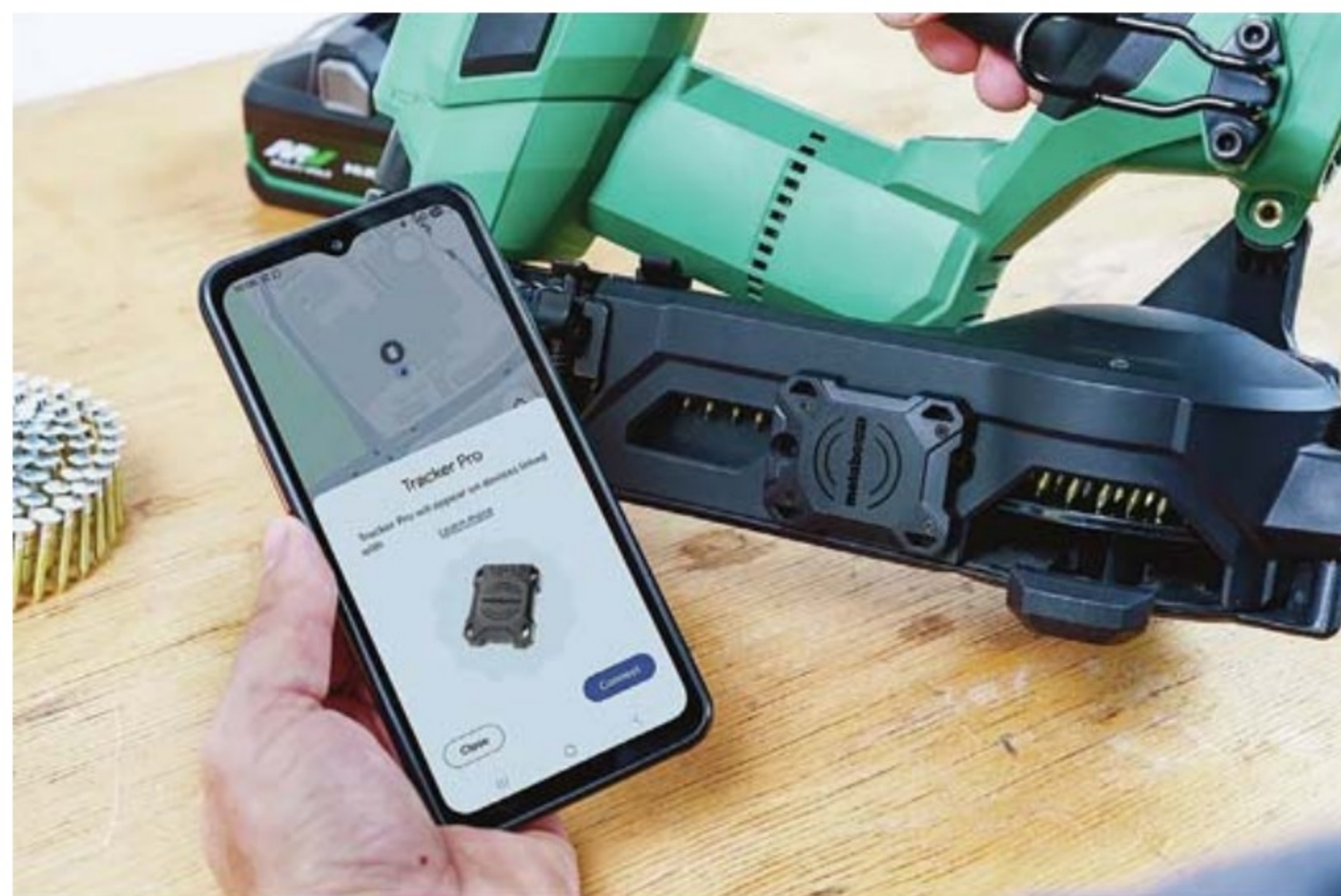

HARDWARE RESOURCES

is launching closet storage solutions under the NorthPoint Closets brand, which aims to help kitchen and bath professionals enter the closet market. Customers can select pre-configured modules or design storage solutions with hanging storage, shelving and drawers. Units ship ready to assemble. Learn more at hardwareresources.com.



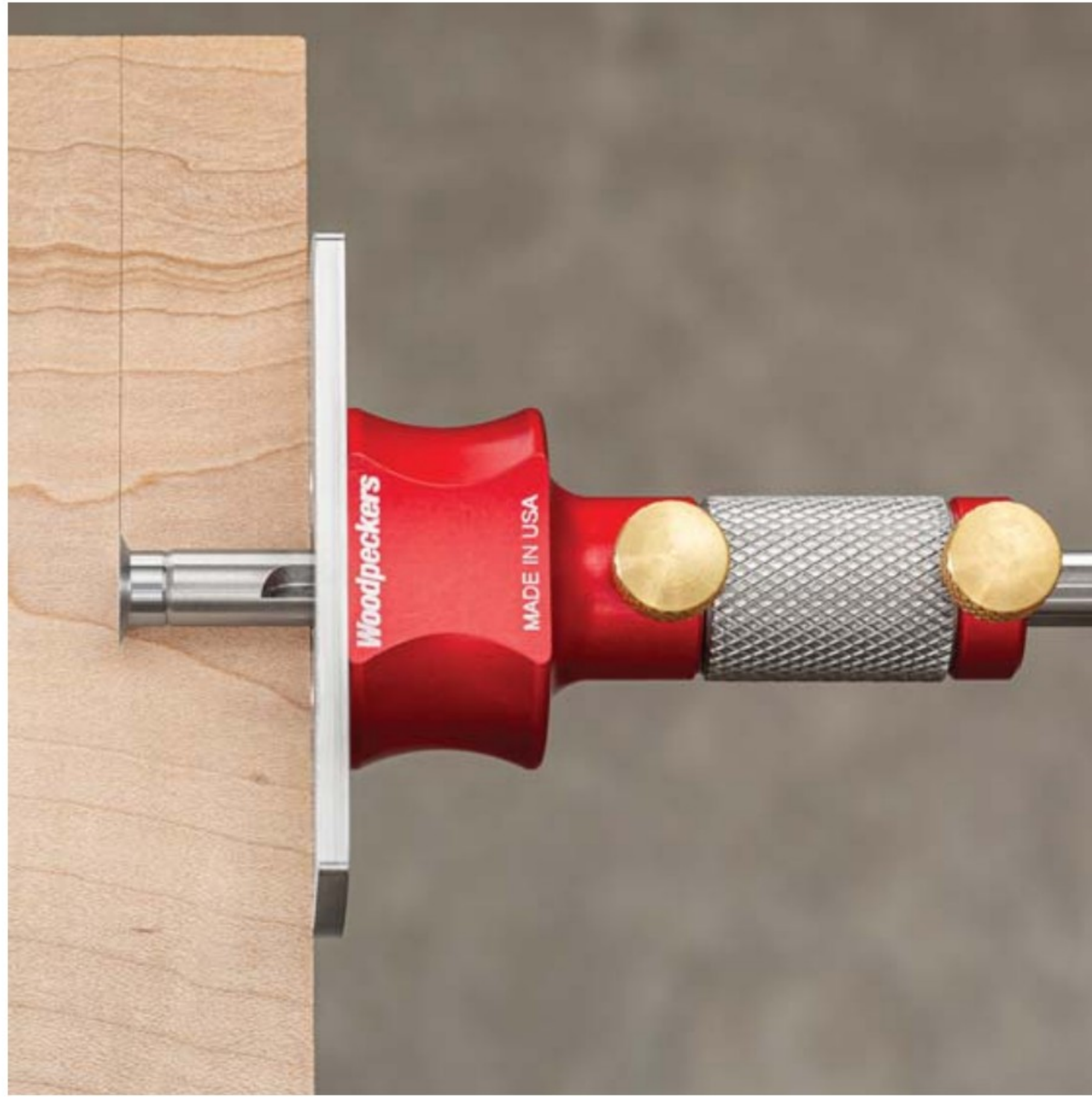

WOODPECKERS has introduced a wheel marking gauge featuring a circular blade designed to create thin lines for hand tool joinery layout. The blade cuts wood fibers rather than marking them, creating a groove that guides chisels or saws. The gauge includes a stainless-steel reference plate and a fine-threaded micro-adjustment mechanism to control the distance between the plate and blade. Learn more at woodpeck.com.



GRIZZLY INDUSTRIAL has launched a mobile stand for benchtop planers and miter saws that supports tools up to 220 pounds. The T34606 Planer/Miter Saw Stand features extendable rollers to support longer workpieces, built-in storage and locking casters for mobility. The stand retails for \$290. Learn more at grizzly.com.

KREG TOOL has introduced a line of trim router accessories to make detailed woodworking tasks easier. Additions include a door hinge routing jig, trim router base plate, circle guide, router bits, and the Kreg Edge Band Clamp, a new clamping solution to eliminate the frustration often associated with applying edge banding. Learn more at kregtool.com.



Schmidt Tooling

For Shapers, Moulders, Tenoners, CNC Routers, Saws, Haunchers & Planers



Standard & Custom

- Hollow Mortising Chisels & Bits
- CNC Tooling, Tool Holders & Accessories
- Insert Style Tenon Heads
- "SCHure Lock" Carbide Knife System
- Insert Style, Rail & Panel Raising Cutters For Cabinet Doors
- T1, M2 & M3, XLW Corrugated and Williams & Hussey Bar Stock
- Carbide & S-Alloy Tipped Knives
- Standard & Custom Profiled Insert Heads
- Multi-profile Rosette Cutters
- Custom Router Bits Insert and Brazed Styles
- Corrugated Back Panel Raising
- Corrugated Back Router Head
- Solid Carbide Spiral & Diamond Tipped Router Bits
- Standard & Custom Knife Grinding
- Insert Style Surfacing Heads Up to 13" Long
- Two Knife Cutter Heads For Shapers & Moulders
- Custom Insert Tooling For HSK Machines
- Standard & Custom Shaper Cutters
- Self-Set Holders and Knives for Planers and Jointers Esta Knives and Disposablade
- Custom Ground Inserts
- Laser Cut - Low Noise Saw Blades

Charles G.G. Schmidt & Co., Inc.
 301 West Grand Ave., Montvale, NJ 07645 www.cggschmidt.com
 Call: 1 800 SCHMIDT or Email: sales@cggschmidt.com
 Accessories, Grinding Room Supplies, Machinery and more Since 1926

Organizations sponsoring meetings, classes or shows of interest to professional or hobbyist woodworkers are invited to submit items to editorial@woodshopnews.com.

Include name, dates, location, description of event and a contact address or telephone number. Calendar items, which should be typed or printed clearly, must be received at least 60 days before the event.

Please note that fees, as listed, might not include materials or shop fees. Check with a specific class for further details.
— Compiled by Jennifer Hicks

CALIFORNIA

Monthly — San Fernando Valley Woodworkers meetings are held on the third Thursday of each month at 7 p.m. at the Balboa Sports Center in Encino. sfvw.org

Monthly — Society of Wood Manufacturing, a chapter of AWFS consisting of educators, manufacturers, hardware and industrial suppliers, and machinery dealers, meets during the second week of each month. For location and dates, visit awfs.org.

Monthly — San Joaquin Fine Woodworkers Association meetings are open to all experience levels at members' shops. For locations and dates, visit sjfwa.com.

FLORIDA

Ongoing — The Dunedin Fine Art Center is offering six-week woodturning classes at its Cottage Campus taught

by AAW professional member Tony Marsh for beginners and intermediate-level participants. Full-day classes are held on Thursdays. Call 727-298-3322 or e-mail education@dfac.org.

Monthly — Woodcrafters Club of Tampa meets every third Thursday evening at 3809 W. Broad St. in Tampa. tampa-woodcrafters.org

GEORGIA

Aug. 25-28 — International Woodworking Fair, North America's largest woodworking technology and design trade show. Location: Georgia World Congress Center in Atlanta. iwfatlanta.com

MAINE

Ongoing — The Center for Furniture Craftsmanship offers year-round classes in woodworking to the highest degree of craftsmanship. One- and two-week workshops from June through October; 12-week Furniture Intensives; a nine-month Comprehensive; eight-week Turning Intensives, and Fellowships. woodscool.org

MARYLAND

Monthly — The Howard County Woodworkers Guild meets the first Saturdays of the month at the Bain Senior Center at 5470 Ruth Keeton Way in Columbia from 9 a.m. to 12 p.m. Contact: Manny Flecker at aaron0641@hotmail.com.

MICHIGAN

June 6-7 — Learn Dovetail Joinery with Jamie Marvin. Fee: \$325. Location: Sam Beauford Woodworking Institute in Adrian. sbwi.edu

June 13 — Woodworking for Teens with Carolyn Racine. Fee: \$225. Location: Sam Beauford Woodworking Institute in Adrian. sbwi.edu

July 6-11 — Mid Century Modern Table - Design & Build. Fee: \$1,400. Location: Sam Beauford Woodworking Institute in Adrian. sbwi.edu

July 6-10 — Contemporary Windsor chair with Michael Jury. Fee: \$1,200. Location: Sam Beauford Woodworking Institute in Adrian. sbwi.edu

MINNESOTA

Monthly — The Minnesota Woodworkers Guild meets on the second Tuesday of each month at various locations. mnwwg.org

Monthly — The Minnesota Woodturners Association meets on the first Saturday of each month (except July) in Plymouth. They also offer a wide range of classes for beginners and advanced turners. mnwoodturners.com



Serving Small Custom Cabinet Makers Since 1982

1-800-237-1326

WalzCraft.com

Custom Doors, Drawer Boxes & Cabinet Components

June 13-14 — American Craft Council – American Craft Fest St. Paul, featuring regional crafts including furniture and woodworking. Location: Union Depot, St. Paul. craftcouncil.org

MONTANA

Aug. 7-9 — Western Design Conference Exhibit & Sale featuring unique creations in furniture, fashion, jewelry, home and lifestyle accessories. Location: Brick Breeden Fieldhouse in Bozeman. westerndesignconference.com

NEW JERSEY

Monthly — The North Jersey Woodworkers Association meets the third Monday of every month. njwawoodworkers.org

Monthly — The Professional Woodworkers Guild of Upper New Jersey meets the third Wednesday of every month. njwoodguild.com

NEW YORK

Monthly — The Woodworkers of Central New York holds meetings on the first Thursday of each month at 6:30 p.m. at the Belgium Cold Springs Fire Department in Baldwinsville. woodcny.org

Monthly — Northeast Woodworkers Association holds meetings on the second Thursday of the month at various

locations in the Albany area. woodworker.org

Monthly — The Long Island Woodworkers meet on the first Wednesday of each month at 7 p.m. at the Frank Brush Barn of the Smithtown Historical Society in Smithtown. liwoodworkers.org

May 17 - 19 — International Contemporary Furniture Fair. Over 450 established and emerging design brands from more than 35 countries will present a broad range of furnishing products for residential, contract and hospitality environments to architects, interior designers, retailers, distributors, developers and press. Location: Javits Center, New York. icff.com

NORTH CAROLINA

Monthly — Triangle Woodworkers Association meetings are held on the third Tuesday of each month at 7 p.m. at Klingspor's Woodworking Shop. Location: MacGregor Village in Cary. trianglewoodworkers.com

Monthly — Charlotte Woodworkers Association meets the third Tuesday of each month, except December, at 6:15 p.m. Location: 8801 Park Road in Charlotte. charlotte-woodworkers.org

OHIO

Ongoing — Cincinnati Woodworking Club meets the sec-

Osborne
Wood Products, Inc.

Wooden Tambour

Top profiles available in 48" and 93" lengths!

45+ YEARS
SINCE 1975

(800) 849-8876 • www.osbornewood.com

Wood finishers achieve high gloss surfaces with SATA

SATA

SATAjet® 5000 B

With the increase of high-quality finishes in the wood finishing market (water borne & urethane materials, high solids, high gloss and even metallic), they require spray equipment that can atomize and apply the coatings properly. SATA has developed spray equipment to handle the most difficult coatings beautifully.

The SATAjet 5000 B HVLP & RP were designed with these complex coatings in mind and will help the wood finisher achieve a beautiful finish with ease. With a nozzle set range from 1.0 to 2.5 the 5000 B can be perfectly matched to the viscosity or technology of the coating you are using.

SATA USA Inc.

Phone: 800-533-8016
E-mail: satajet@satausa.com
www.satausa.com

Scan for INFO on the SATAjet 5000 B

Facebook, YouTube, Instagram, LinkedIn icons and a QR code.

ond Saturday in the months of Jan., March, May, Sept. and Nov. from 8:30 a.m. to 12:30 p.m. at the E.B. Mueller in Reading. cincinnatiwoodworkingclub.org

PENNSYLVANIA

Monthly — Lehigh Valley Woodworkers Guild meets at 6:30 p.m. every third Tuesday of the month at the Woodcraft in Allentown. Various craftspeople provide presentations on their woodworking techniques. lvwwwg.com

PUERTO RICO

May 5-7 — Wood Industry Conference, hosted by the Wood Industry Association. Connect with fellow woodworking machinery importers, manufacturers, distributors and suppliers. Hear informative keynotes, take part in networking opportunities, and more. Location: El Conquistador Resort in Fajardo. woodindustry.org

SOUTH DAKOTA

Monthly — The South Dakota Woodworkers Guild meets the last Thursday of every month, except August, at various members' shops. The club has hand tool and woodturning groups. Learn more at sdwoodworker.org. **W**

GEMINI INDUSTRIES PROMOTES DAVID JACKSON

Gemini Industries announced that David Jackson has been promoted to director of product management. Jackson will oversee development of new technologies and manage the company's existing product lineup.

During his tenure at Gemini, Jackson has held multiple roles across various departments. His work has supported product development and sales operations.

"David's leadership will be instrumental as we continue to strengthen Gemini's position in the markets we serve and execute on our long-term growth strategy," said Kevin Laughlin, vice president of sales at Gemini Industries.

NWA READIES FOR WOODWORKERS SHOWCASE

The Northeastern Woodworkers Association will host its 33rd annual Woodworkers Showcase at the Saratoga Springs City Center in Saratoga Springs, N.Y., on March 28-29.

The show will present over 500 exhibits reflecting the art of woodworking, including fine furniture, turnings, carvings, intarsia, scroll work, sculpture, toys, and musical instruments.

Exhibitors, both amateur and professional, compete for awards in multiple categories, including Best of Show and People's Choice.

The show also features lectures and demonstrations. This year's guests include Tom McLaughlin, host of Epic Woodworking, and Logan Wittmer, editor of Popular Woodworking.

Learn more at woodworker.org.

APRIL 2026

52

WOODSHOPNEWS

**JOIN WOOD AT ANY ANGLE
NO CLAMPS, NO NAILS, NO STAPLES**

- Bench-top routing machines with manual or pneumatic operation for any size shop
- Equipped with larger motors and greater machining capacities vs. previous models
- Available with digital displays for keyway locations and routing heights
- View videos and technical specs. online at www.hoffmann-usa.com



MU-3PD Bench-top Routing Machine



Hoffmann-USA.com
Toll-free: (866) 248 - 0100



Drawer Slide Spacers

Family Owned Since 1960!



We Build Injection Molds!

Please visit our website www.bainbridgemfg.com



Call 1-509-745-9555

or email info@bainbridgemfg.com

CLASSIFIED MARKETPLACE

E-Mail marketplace@woodshopnews.com for Advertising Information

Bits Blades Tooling

**HSK 63F
Tool Holders - \$149.00**



ER40 Collets - \$19.00

SNX
www.snstechnologies.com
(320) 380-3800

Doors Drawers

Custom
Components
to Complete
Cabinetry



Elias Woodwork

1-800-665-0623
www.eliaswoodwork.com

Doors Drawers

"Your Single Source
Provider"



Doors, Drawers & More

- No Quantity Limits
- Over 70 Different Grades/Wood Species
- Design Flexibility
- Custom Sizes
- Finished or Unfinished
- Timely Delivery



Walz Craft

WalzCraft.com 800-237-1326

Fasteners



MONARCH
METAL FABRICATION

Easy Wall Panel System

Simple, decorative
aluminum trim



(631) 750-3000
monarchmetal.com

WOODSHOP
NEWS

203-952-6790

rbeglin@aimmedia.com

Hardwoods



www.rarewoodsusa.com • (207) 364-1520
120 species of exotic & domestic woods
Ebony, Olive, Rosewood, Satinwood, etc.
\$3 million inventory – buy 1 plank or 1000!

STEVE WALL LUMBER CO.
Quality Hardwoods and Woodworking Machinery
For The Craftsman and Educational Institutions.

The trusted supplier from the Heart
of North Carolina Furniture County.

- HARDWOODS • EXOTICS • THIN CRAFTWOOD • AROMATIC CEDAR
- HARDWOOD PLYWOOD • CUSTOM PANEL DOORS • HARDWOOD FLOORING

See Our Catalog on the WEB: walllumber.com

BOX 287 • MAYODAN, N.C. 27027
336-427-0637 • 1-800-633-4062
Email: wood@walllumber.com
SEND \$1.00 FOR CATALOG

WOODSHOP NEWS

FOR MORE INFORMATION CONTACT:

Rory Beglin

203-952-6790

rbeglin@aimmedia.com

www.woodshopnews.com

*Advertise
Here!*

203-952-6790

or email:

rbeglin@aimmedia.com

WOODSHOP
NEWS

CLASSIFIED MARKETPLACE

E-Mail marketplace@woodshopnews.com for Advertising Information

Lumber



LET'S GET WOODWORKING

HARDWOOD LUMBER & PLYWOOD

KILN DRIED HARDWOODS: Domestic, Imported, Figured & Quartersawn

PLYWOOD: Domestic, Imported, Cabinet & Marine Grade

L.L. JOHNSON LUMBER MFG CO & JOHNSON'S WORKBENCH

theworkbench.com | 800-292-5937

Moisture Meters



Moisture Meters

multiple use
in-kiln and everywhere else

Call
800-227-2105
www.Lignomat.com

Services

CNC ROUTER BIT SHARPENING

Spiral & Compression Router Bits Sharpened to Factory Specifications, using 5 Axis CNC Grinder

DISCOUNTED PRICING ON CNC TOOLING FROM:

VORTEX
TOOL COMPANY INC

Amana Tool
REDEFINING WOODWORKING

LMT-ONSRUD **FS TOOL**

100% Satisfaction Guaranteed

FAST TURN-AROUND & FREE SHIPPING ONE WAY!

CONNECTICUT SAW & TOOL

800.404.1220

140 Avon Street • Stratford, CT 06615
info@ctsaw.com • www.CTSAW.com

Measuring Systems



HOFFMANN

Hoffmann-USA.com
(866) 248 - 0100

GLIDE & STOP

DAWLEY STOP SYSTEMS

Scraping & Sanding



THE HANDY HEAVY-DUTY EDGEBAND TRIMMING TOOL

Li'l Pucker

SNX

www.snxtechnologies.com
(320) 380-3800

Veneer

SUPERIOR VENEER
Artisan Thick

1/16" Artisan Thick domestic & exotic veneers

4 x 8 & 4 x 10
5 x 8 & 5 x 10

Available as:
Face
Paperbacked
MDF, Particle Board, Veneer Core substrates

S www.superiorveneer.com
ph:855.940.7827 fax:812.941.8780
1819 Dewey St. New Albany, IN 47150



The classifieds have what you need.

Call: 203-952-6790

PLACE YOUR AD HERE!

CALL
203-952-6790

Place your ad TODAY!



THE LOG & TIMBER HOME SHOW

Find everything you need to build your dream wood home — all under one roof!



Meet with the industry's foremost log and timber home producers. See first-hand how various building systems are constructed.



BECOME A KNOW-IT-ALL!

Attend our **Log & Timber University** for detailed, step-by-step instructions on budgeting, planning and building your dream home.

The course is \$95 per person or \$129 per couple (plus \$30 for each additional attendee with the group). This fee covers the Course Guide, a comprehensive textbook to guide you through the entire homebuilding process; a notepad and assorted log & timber magazines; continental breakfast or snacks; plus FREE Lifetime Alumni Pass to the Log & Timber Home Shows.

presented by

LOG HOME
LIVING

Timber Home Living

Cabin LIFE .com

Visit www.LogHome.com/shows to find a show near you!

APRIL 2026

55

WOODSHOPNEWS

ADVERTISING INDEX

Amana Tool.....	www.amanatool.com	C4	JPW Industries	www.jpwindustries.com	9
Anderson America Corp.	www.andersonamerica.com	1	KLINGSPOR Abrasive	www.klingspor.com	5
Bainbridge Manufacturing.....	www.BainbridgeMfg.com	52	Lignomat USA, LTD.....	www.lignomat.com	12
BESSEY Tools North America	www.besseytools.com	21	Lockdowel.....	www.lockdowel.com	13
Blum Inc.....	www.blum.com	C2	MARTIN Woodworking Machines	www.martin-usa.com	2
BRIWAX International, Inc	www.briwax.com	15	New England Drawer.....	www.newenglanddrawer.com	41
Cantek America Inc	www.cantekamerica.com	17	Oneida Air Systems Inc	www.oneida-air.com	33
Castaly Machine	www.castalymachine.com	23	Osborne Wood Products, Inc	www.osbornewood.com	51
Castle USA.....	www.castleusa.com	19	Pantorouter / Woodcraft Solutions.....	www.PantoRouter.com	32
Charles GG Schmidt & Co.....	www.cggschmidt.com	49	Richelieu.....	www.richelieu.com	27
Connecticut Saw & Tool.....	www.ctsaw.com	3	SATA	www.sata.com	51
Fine Woodworking New England .	https://bit.ly/4kUUBbw	C3	Shaper Tools.....	www.shapertools.com	7
Gibbs Group N.A.	www.GibbsGroupNA.com	37	Shop Fox	www.shopfox.biz	11
Grizzly Industrial, Inc	www.grizzly.com	28-29	Vexor Custom Woodworking Tools.....	www.vexorcwt.com	45
Hafele America Co.....	www.hafele.com/us	4	Vista Finishing	www.vistafinishing.com	22
Hoffmann Machine Company	www.hoffmann-usa.com	52	WalzCraft Industries Inc.	www.WalzCraft.com	50

KBIS honors best exhibitors

The Kitchen & Bath Industry Show announced its 2026 Best Booth Award winners following the Feb. 27-29 event at the Orange County Convention Center in Orlando, Florida.

The awards recognized exhibitor creativity and design excellence at KBIS 2026, hosted by the National Kitchen & Bath Association in conjunction with the National Association of Home Builders' International Builders' Show during Design and Construction Week. Emerald produced the event.



The display of two-time winner Plain and Fancy Custom Cabinetry, a manufacturer in Schaefferstown, Pa.

"Every year at KBIS, we are captivated by the stunning exhibit displays and new products showcased by the industry's leading brands," Jason McGraw, group vice president and KBIS show director at Emerald, said in a statement. "With great planning, creative design and significant investment, this year's Best Booth Award winners have dazzled attendees with their innovation and impressive displays."

McGraw presided over this year's awards with Amy



Daltile, a tile manufacturer, won for Best Grand Booth.



Best in Show: Kohler turned heads with a setup featuring individual rooms and a wrought iron gate.

Hornby, KBIS associate show director at Emerald.

Winners were recognized on the show floor's NEXTstage for exceptional creativity, design and attendee experience.

Best booth award winners by size:

- Best in Show: Kohler
- Best Grand Booth: Daltile
- Best Large Booth: Fabuwood
- Best Medium Booth: Plain & Fancy Custom Cabinetry
- Best Small Booth: IKONNI

Best booth award winners by category:

- Best New Exhibitor: Cava Surfaces
- Best Surfaces Booth: Cosentino
- Best Appliance Booth: GE Appliances
- Best Cabinetry Booth: Plain & Fancy Custom Cabinetry
- Best Plumbing Booth: Kohler
- Best Hardware, Lighting & Accessories: Plank Hardware **W**

—Jennifer Hicks

60 Grit

Rough humor by Steve Spiro





Fine Wood Working **NEW ENGLAND**

MAY 1-2, 2026

HOSTED BY

Connecticut Valley
School of Woodworking

Join Fine Woodworking at our in-person event on **May 1-2, 2026** hosted by the **Connecticut Valley School of Woodworking, 249 Spencer St, Manchester, CT 06040.**



Learn more at FineWoodworking.com/new-england*

THE ONE & ONLY!



EXTREME PERFORMANCE CNC BITS



The original colorful extreme coated Industrial Spektra™ router bits feature a micro-thin nACo ceramic coating that enables the tool's cutting edge to retain crucial sharpness and lubricity.



**HARDER
CARBIDE**

UP TO
2.5X
LONGER LIFE



INDUSTRIAL SAW BLADES

DESIGNED TO OUTPERFORM!

Large, European Micrograin Carbide Tips

German Steel Saw Bodies Hand Hammered to Ensure Minimum Runout

Improved Laser Slot Geometry Reduces Noise & Vibrations for a Smoother Operation



Amana Tool®