

EST. 1901

THE ORIGINAL AND STILL THE BEST

# The Woodworker

March 2016

www.getwoodworking.com

& Woodturner

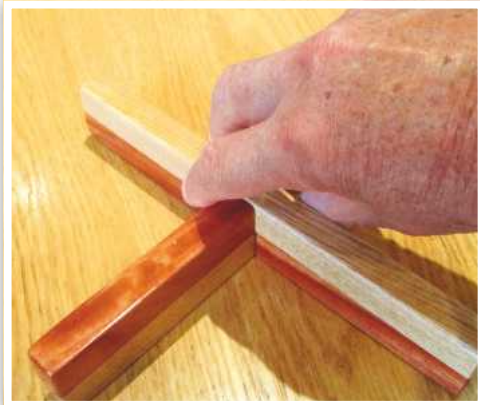

**CHILD'S PLAY**



**ROLL UP!**



**TOP SAW**

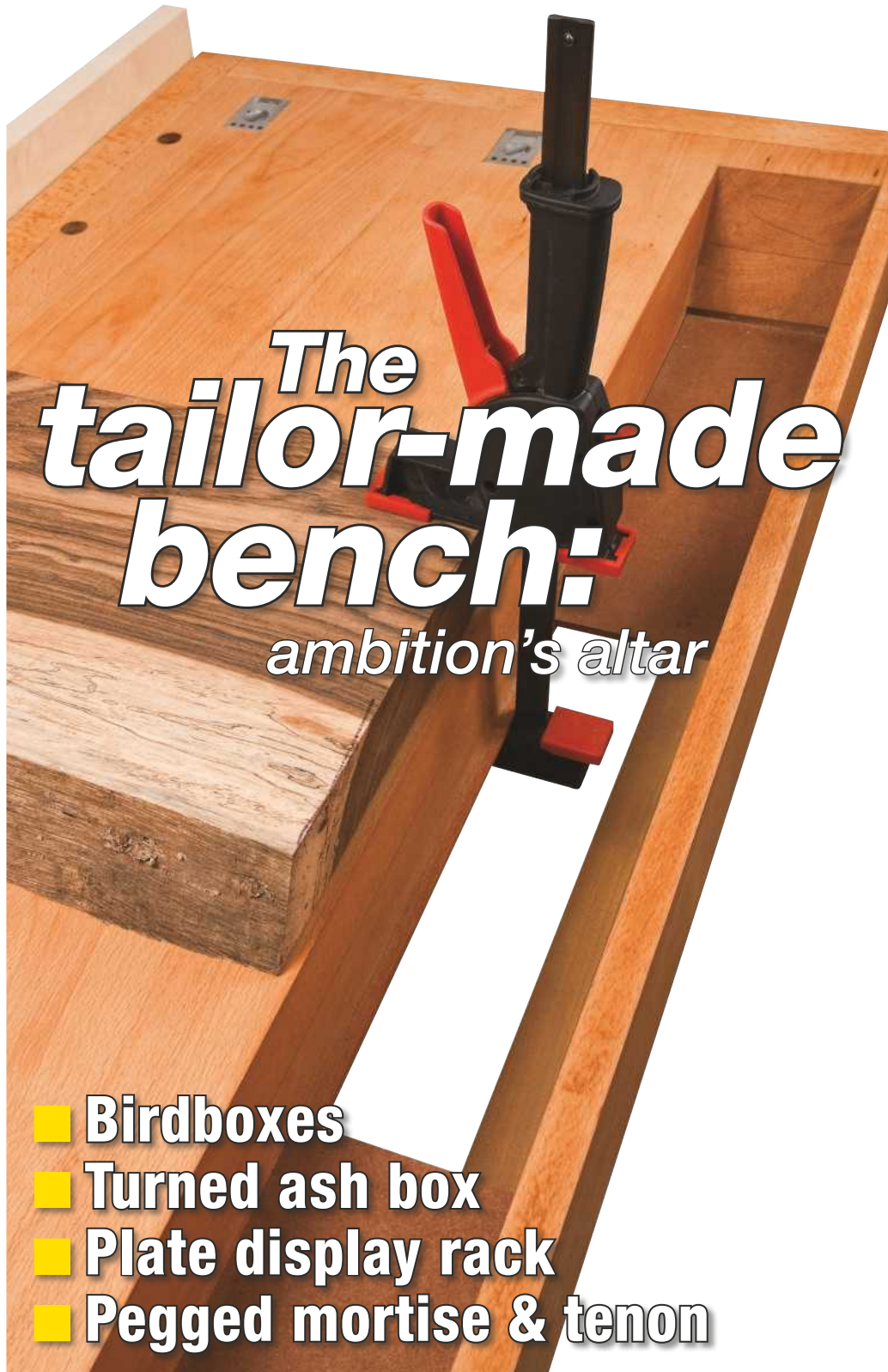

*The*  
**tailor-made**  
**bench:**  
*ambition's altar*

- Birdboxes
- Turned ash box
- Plate display rack
- Pegged mortise & tenon

**PLUS: LATEST WOODWORKING NEWS AND TOOLS**

mytime media WOODWORKING GROUP



2425

# IronmongeryDirect

## MASTERS OF OUR TRADE

# UK'S BIGGEST RANGE



## 15,000 PRODUCTS IN STOCK FOR NEXT DAY DELIVERY

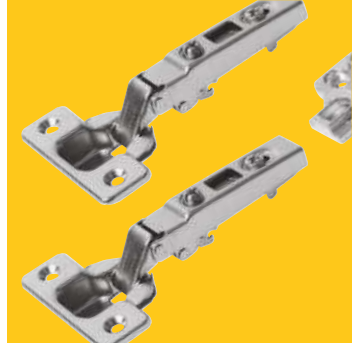

CALL  
0808 168 28 28  
OR GO ONLINE  
TO GET YOUR  
**FREE**  
CATALOGUE

 **ORDER BY 8PM**  
GET IT NEXT DAY

 **FREE DELIVERY**  
OVER £45\*

 **FREE RETURNS**  
WITHIN 30 DAYS

 **MINIMUM**  
5 YEAR  
GUARANTEE

 **LOW**  
TRADE  
PRICES

DOWNLOAD OUR FREE APP

Available on the  
App Store

GET IT ON  
Google play



CALL 7am-8pm 7 days a week  
**0808 168 28 28**

 **ONLINE Shop 24/7!**  
**IronmongeryDirect.com**

FIND US ON  

\*Ex VAT

# Welcome

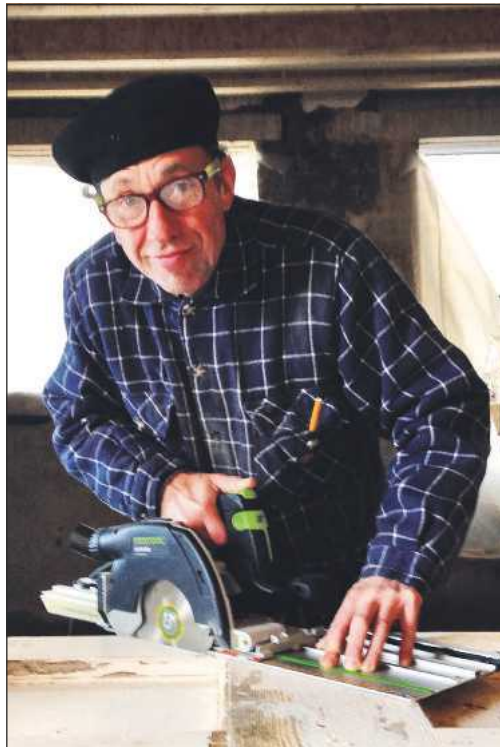

There are some jobs that seem as if they will never get done, and no matter how much work you do, the end seems as far away as ever. It might not come as any surprise to you the reader that I am involved in such a job right now. It was one of those ones which you take on in a single weak moment and regret for a great many weaker ones. It's a restoration job and has involved a large amount of site work in a very exposed position, with only occasional relief in a dark gloomy interior.

Having been rained off yesterday ('Hurricane Jonas' I was informed by Tom my helper, doing his best to converse normally through chattering teeth and blue lips), I found myself an inside job today and watched wistfully as people strolled about under a blue sky in the golden sun the whole day long. But at least things aren't dull when one is working outdoors, the uncertainty of the weather alone provides something bordering on excitement. It's not uncommon to have tools and kit – including my step ladder – blown about and generally rained upon as you struggle to tighten the

clamps up or something equally as imperative. And first thing in the morning, the sound of torrential rain on the bedroom window can spark a childish feeling of excitement for the unexpected day off school, and you find that you just have to give in and pull the covers up for another 10 minutes. It's a wonder how anything gets built sometimes, but as long as you've not signed up to a penalty delay clause, then a few days extra on a job isn't such a bad thing.

So, whether it's in the (relative) warm and dry of the workshop or the character building challenges of an outdoor site in January, it's all good fun and definitely helps to keep this woodworker from getting stale. And let's not forget, freshness is the vital thing, whether naturally of mind and spirit or brought about by taking on a new type of work that has yet to be fully explored. Whatever it is, though, and before you start, just make sure that the end won't be too far away...

*Mark*

You can contact Mark on [mark.cass@mytimemedia.com](mailto:mark.cass@mytimemedia.com)



If you can't always find a copy of the magazine, help is at hand! Complete this form and hand it in at your local store, and they'll ensure that a copy of each issue is reserved for you. Some stores may even be able to arrange for it to be delivered to your home. Just ask!

*Subject to availability*

Please reserve/deliver my copy of *The Woodworker* on a regular basis, starting with issue \_\_\_\_\_

Title \_\_\_\_\_ First name \_\_\_\_\_

Surname \_\_\_\_\_

Address \_\_\_\_\_

\_\_\_\_\_

Postcode \_\_\_\_\_

Telephone number \_\_\_\_\_

If you don't want to miss an issue



## WOODWORK

### 14 Neat as a pin

Andy Standing shows you how to make a pegged mortise & tenon

### 18 Write on!

Colin Simpson takes you through the first stages of restoring a lovely writing bureau back to its former glory

### 27 Child's play

Tony 'Bodger' Scott makes a puzzle for kids that baffles grown-ups

### 32 A home for feathered friends

John English shows you how to make an easy-clean home for birds using small scraps

### 36 Sunday best on show

Gordon Warr shows you an easy and effective means of displaying your favourite mugs and plates

### 50 The altar of ambition

A tailor-made bench that suits your needs and preferences, says Tony Sutton, reflects your woodworking aspirations

### 67 Skirting round the details

Even simple skirting can provide a decorative feature, as James Hatter shows

### 73 Weapon of choice

Mike Riley's quick on the drawknife's benefits, but there's a startling concession, too



March 2016

Published by MyTime Media Ltd  
Enterprise House, Enterprise Way,  
Edenbridge, Kent TN8 6HF

Tel: 0844 412 2262  
From outside UK: +44 (0)1689 869840  
www.getwoodworking.com

## SUBSCRIPTIONS

UK – New, Renewals & Enquiries  
Tel: 0844 243 9023  
Email: help@tw.secureorder.co.uk  
USA & CANADA – New, Renewals & Enquiries  
Tel: (001)-866-647-9191  
REST OF WORLD – New, Renewals & Enquiries  
Tel: +44 1604 828 748

## BACK ISSUES & BINDERS

Contact: myhobbystore.co.uk/contact  
Website: www.myhobbystore.co.uk/magazines

## EDITORIAL

**Group Editor:** Tegan Foley  
Email: tegan.foley@mytimemedia.com  
**Editor:** Mark Cass  
Email: mark.cass@mytimemedia.com

## PRODUCTION

**Designer:** Malcolm Parker  
**Retouching Manager:** Brian Vickers  
**Advertising Production:** Robin Gray

## ADVERTISING

**Business Development Manager:** David Holden  
Email: david.holden@mytimemedia.com  
Tel: 01689 869867

**Online Sales:** David Holden  
Email: david.holden@mytimemedia.com  
Tel: 01689 869867

## MARKETING & SUBSCRIPTIONS

**Subscriptions Manager:** Kate Hall  
**Subscriptions:** Sarah Pradhan  
Tel: +44(0)1858 438798

## MANAGEMENT

**Head of Design & Production:** Julie Miller  
**Group Advertising Manager:** Rhona Bolger  
Email: rhona.bolger@mytimemedia.com  
Tel: 01689 869891

**Chief Executive:** Owen Davies  
**Chairman:** Peter Harkness

**mytimemedia**  
print & digital media publishers

© MyTime Media Ltd. 2016  
All rights reserved ISSN 1752-3524

The Publisher's written consent must be obtained before any part of this publication may be reproduced in any form whatsoever, including photocopyers, and information retrieval systems. All reasonable care is taken in the preparation of the magazine contents, but the publishers cannot be held legally responsible for errors in the contents of this magazine or for any loss however arising from such errors, including loss resulting from negligence of our staff. Reliance placed upon the contents of this magazine is at reader's own risk.

The Woodworker & Woodturner, ISSN 1752-3524, is published monthly with an additional issue in summer by MYTIME MEDIA Ltd, Enterprise House, Enterprise Way, Edenbridge, Kent TN8 6HF, UK.

The US annual subscription price is 59GBP (equivalent to approximately 98USD). Airfreight and mailing in the USA by agent named Worldnet Shipping Inc., 156-15, 146th Avenue, 2nd Floor, Jamaica, NY 11434, USA.

Periodicals postage paid at Jamaica NY 11431.  
US Postmaster: Send address changes to The Woodworker & Woodturner, Worldnet Shipping Inc., 156-15, 146th Avenue, 2nd Floor, Jamaica, NY 11434, USA  
Subscription records are maintained at dsb.net 3 Queensbridge, The Lakes, Northampton, NNA 7BF.  
Air Business Ltd is acting as our mailing agent.



When you have finished with this magazine please recycle it.

Paper supplied from wood grown in forests managed in a sustainable way.



## TURNING

### 43 Turn up your own accessories

Ian Wilkie shows how you can save some pennies by turning your own regularly used workshop accessories, including sanding drums and a DIY mandrel

### 59 Offset elegance

Colin Simpson goes back to box making this month and shares an idea for incorporating a graceful curve

## ON TEST

### 78 Festool HK 55 EQ saw with FSK 420 rail

### 80 Triton T20 combi hammer drill

### 81 Smart SMTX Multi-Fit blades

### 82 Kennedy Benchtop Workstation & Keter Folding Workbench

### 84 Stubai chisels

## REGULARS

- 3 Welcome
- 10 News
- 13 News from D&M Tools
- 30 Diary
- 49 Readers' letters
- 64 Subscriptions
- 89 Marketplace
- 90 Archive

**SUBSCRIBE**  
& SAVE UP TO 38%  
PLUS: RECEIVE A FREE  
PICA-DRY & PICA POCKET MARKER



SEE PAGE 64  
FOR DETAILS

OFFER CLOSES 11 MARCH 2016

73

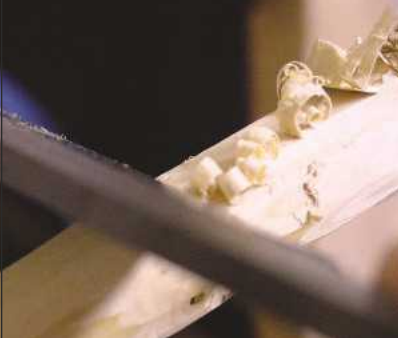

78



# 'THE' TOOL SUPERSTORE

HAND, POWER TOOLS & MACHINERY SPECIALIST

## DM-TOOLS.CO.UK

### YOUR TRUSTED PARTNER

D&M Tools has been family owned and managed since 1978. During that time we have earned a reputation with our customers as a trusted partner. Whether you are a trade professional or a DIY enthusiast, our mission is a simple one - to supply top quality tools at the best value for money, backed up by a service you can trust.

### LOW TRADE PRICES!

Whether you're buying online, by phone, email, post or visiting us in-store, D&M provides you with the widest range of quality hand, power tools and woodworking machinery all at the keenest prices.

### OVER 10,000 LINES IN STOCK!

We hold massive stocks, meaning that most items are available for despatch the day you order it. Our website shows up to date stock availability, so you can order with confidence.

### FREE DELIVERY

Delivery to UK mainland addresses is free for most orders over £99 and for orders under £99 is only £5.95. See the carriage rates on our website for full details.



### 1 HR DELIVERY WINDOW

We use DPD Predict for the majority of our deliveries (except heavy or oversize items) so you will receive a 1 hour delivery window via email or text meaning you don't need to wait in all day.

### SHOP ON-LINE 24HRS A DAY

Visit our easy-to-use website to see what we mean about range and value. Browse and buy with confidence 24hrs a day from the biggest brands in the business, all at prices you'll find hard to beat.

Here you will find all our **latest offers and deals**.

Why not **subscribe to our regular emails** to keep up with our latest deals and offers or join our **D&M Loyalty Scheme** and earn valuable loyalty points every time you shop.

More details on our website: [www.dm-tools.co.uk](http://www.dm-tools.co.uk)



**MAKE A DATE IN YOUR DIARY...**

## MASSIVE CHOICE FROM THE BIGGEST BRANDS!



### THE UK's No.1 BRANDED HAND, POWER TOOLS & MACHINERY EVENT



'THE' TOOL SHOW '16

[WWW.THETOOLSHOW.COM](http://WWW.THETOOLSHOW.COM)

**KEMPTON PARK RACECOURSE**  
**7th-9th OCTOBER 2016**

**VISIT OUR EXTENSIVE TWICKENHAM SUPERSTORE**  
**73-81 HEATH ROAD • TWICKENHAM • TW1 4AW**  
**020 8892 3813 • SALES@DM-TOOLS.CO.UK**



**020 8892 3813**  
**MON-SAT 8.30am-5.30pm**  
**(CLOSED BANK HOLIDAYS)**



**FREE CATALOGUE**  
**- OVER 650 COLOUR PAGES**



**VISIT OUR EXTENSIVE TWICKENHAM SUPERSTORE**

## OUR CUSTOMERS LOVE US!

We are regularly receiving 5 star reviews on the independent review site Trustpilot, as well as testimonials direct from our customers, here are just a few:

★★★★★

**"D&M tools are very well priced, turn up on time and have superb telephone support just in case anything goes wrong.** This is a business I will use in the years to come. Thanks for a job well done."

★★★★★

**"Quick Quality Quantity and Value - D&M offer a fast efficient service which they couple with an excellent range of manufacturers tools which are always available in the numbers you need at a competitive price."**

★★★★★

**"Best customer service... Ever! - I believe the real test of a companies customer service is when they have to deal with problems. My delivery came quickly and well packaged. I had an issue with the tool after about a month of use. The guys in the phone quickly arranged for collection, repair of the tool and return with great communication throughout. Very pleased with the way they resolved my issue."**

★★★★★

**"Brilliant prices and brilliant service - I have now traded with D&M Tools twice now and both times have received impeccable service and also nothing is to much trouble for their staff to sort out."**

★★★★★

**"Excellent service makes a refreshing change - first time I have used this company, was quite amazed by the quality and speed of service and delivery, a fine example of what can be done with first class staff."**

★★★★★

**"Best place for tools online - I've bought a lot of gear from D&M Tools over the last few years and they always provide a first class service, plus they always seem to have everything I need at the time."**

[www.trustpilot.co.uk/review/www.dm-tools.co.uk](http://www.trustpilot.co.uk/review/www.dm-tools.co.uk)



Andrew Hall



Mick Hanbury



Wayne Mack



Jennie Starbuck



Tony Wilson



Peter Setton



Michael Painter



Nic Westermann



Martin Pidgeon



# MIDLANDS WOODWORKING & POWER TOOL SHOW

NEWARK SHOWGROUND NG24 2NY  
18<sup>TH</sup> & 19<sup>TH</sup> MARCH 2016

FOLLOW US  
ON FACEBOOK



FOLLOW US  
ON TWITTER



***A great day out full of Demonstrations,  
Personalities, Trade Stands, Advice & Fun***

Advance tickets can be  
purchased by calling the  
ticket hotline:

**01474 536535**

or securely through PayPal at

**[www.nelton.co.uk](http://www.nelton.co.uk)**

**Free parking, Showguide and Raffle.**

**Open Hours:**

**10:00am – 4:00pm Both Days.**

**Entry:**

**One day £8 / In advance £6**

**Two days £12 / In advance £8**

**Under 16's Free**

**Advance tickets on sale from 5th January 2016**

**(Ticket Hotline closes 14th March 2016)**



**MADE STRONGER. LASTS LONGER.™**

**25%**  
**STRONGER\***

**IRWIN WELDTEC™  
CONSTRUCTION BLADE  
WITH WELDED  
CARBIDE TEETH**

irwin.co.uk \*When compared to IRWIN part number 1897209. Tested for durability on the most demanding applications.

**IRWIN®**  
**TOOLS**

# In brief...

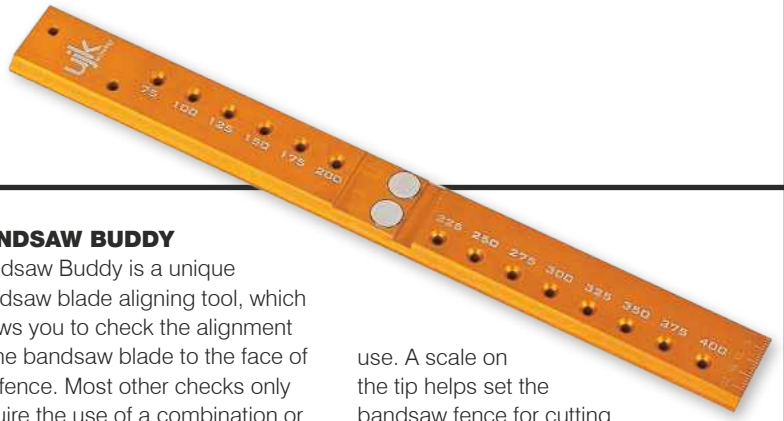

## Tsuboman ATOMA



### CUTTING EDGE TECHNOLOGY FROM ATOMA

Johnson Tools are delighted to have been appointed the official UK distributor of Tsuboman Atoma diamond sharpening plates from Japan.

Very highly regarded in Japan but until recently the Atoma diamond plates have been virtually unheard of outside their country of origin.

The Atoma plates differ from other diamond plates in that the microcrystalline diamonds are arranged in clusters as opposed to being a continuous covering. This arrangement of the diamonds abrades much more aggressively than the more commonly available diamond plates and coupled with Atoma's use of superior polycrystalline diamonds, ensure a consistent cutting performance and exceptional wear qualities for longer life span.

The high fracture resistance offered by polycrystalline results in a surface that cuts quickly, resists wear and produces far more consistent scratch patterns. The cluster pattern also minimises loading and hydraulic lock.

As with all diamond tools the Atoma plates should be flushed with water or light oil while in use to prolong the life and performance. The diamonds are electro-bonded to a stainless-steel sheet that is mounted to a 10mm-thick aluminium block. This type of construction makes the plates durable, rust resistant and extremely flat.

In Japan the Atoma plates are commonly associated with flattening and dressing Japanese waterstones but they are superb stones in their own right for standard dressing and sharpening of any edge tool, such as plane irons, chisels or router cutters. All Atoma plates measure 210 x 75mm and are available in the following four grades (140, 400, 600 and 1,200) with prices ranging from £79.99-£89.99. See [www.johnsonstools.co.uk](http://www.johnsonstools.co.uk).

### BANDSAW BUDDY

Bandsaw Buddy is a unique bandsaw blade aligning tool, which allows you to check the alignment of the bandsaw blade to the face of the fence. Most other checks only require the use of a combination or engineer's square. Truing the fence to the blade is tricky. Bandsaw Buddy has two rare earth magnets, which hold it firmly on the blade. At 250mm long it is easy to spot any discrepancy and then make necessary adjustments. The magnets will keep it safely stored on the bandsaw's frame when not in

use. A scale on the tip helps set the bandsaw fence for cutting veneers or thin boards. Holes along the Buddy's length at 12.5mm intervals allow you to draw arcs or circles in 25mm steps from 75-400mm, a useful feature for marking curves or when cutting bowl blanks. Accurately machined from anodised aluminium, it also makes a handy straightedge. Priced at £19.99, see [www.axminster.co.uk](http://www.axminster.co.uk).

### BUILD YOUR SKILLS WITH WOODRIVER PLANES

Wood Workers Workshop has a great offer for anyone buying any WoodRiver hand plane from [www.woodworkersworkshop.co.uk](http://www.woodworkersworkshop.co.uk). Anyone purchasing one of the US-designed WoodRiver planes gets three months' free subscription to 75, 30-minute sessions alongside access to over 1,100 previous episodes with five new ones each week.

The exclusive offer gives free access to Rob Cosman's amazing interactive online hand and power tool workshops. Based in Canada, Rob has worked with many of the world's best craftsmen, including Tage Frid, and has been

an active demonstrator at international woodworking shows for over 10 years.

He brings his well-respected techniques to your home workshop via the internet. He has been instrumental in the development of the US brand of WoodRiver planes and these are sold exclusively by Wood Workers Workshop in the UK and Europe after owner Peter Sefton bench tested them at his Furniture School; he and his students were so impressed they now use them on a daily basis.

It's a great way to get the most out of your new WoodRiver plane and build your skills!

**Wood Workers Workshop**

**THE VERY BEST WOODWORKING TOOLS**  
Sourced by woodworkers for woodworkers

**IronmongeryDirect**  
MASTERS OF OUR TRADE

**ORDER BY 8PM**  
**GET IT NEXT DAY!**

**FREE CATALOGUE Visit [IronmongeryDirect.com](http://IronmongeryDirect.com)**



## Woodworking & Furniture Making Courses

Learn to craft wood and make fine furniture on our long and short courses at purpose-built workshops in Worcestershire

**Short Courses Include**  
 French Polishing & Refinishing  
 Wood Machining  
 Dovetailing & Drawer Fitting  
 Veneering & Laminating  
 Routing  
 Sharpening  
 'Make a Box'  
 'Make a Table'  
 Beginners Course



Sam Carter  
9 month student



Rick Howie  
9 month student



Veneering & Laminating  
4 day course



Paul Smith  
9 month student

Call us on **01684 591014**  
 or find us online for information on all the courses:  
[www.peterseftonfurnitureschool.com](http://www.peterseftonfurnitureschool.com)  
 The Threshing Barn, Welland Road, Upton upon Severn, Worcestershire, WR8 0SN



## Wood Workers Workshop



**01684 594683**  
[www.woodworkersworkshop.co.uk](http://www.woodworkersworkshop.co.uk)  
 The Threshing Barn, Welland Road,  
 Upton upon Severn, Worcestershire, WR8 0SN

INCR  
 Woodpeckers  
 WoodRiver



## THE VERY BEST WOODWORKING TOOLS

Sourced by woodworkers  
 for woodworkers

Quality tools from the finest  
 UK, US & Canadian manufacturers



GET INSPIRED



### FAST & ACCURATE RIP-CUTS.

The Rip-Cut™ speeds and simplifies the process of ripping down large plywood and MDF panels. There is no need for measuring, marking, or chalk lines.

Attaches to almost any circular saw

Cuts accurately from 1/8" to 24" wide

Find your nearest stockist  
[kregtool.eu](http://kregtool.eu)



# YANDLES SPRING WOODWORKING SHOW

FRIDAY 8<sup>TH</sup> AND SATURDAY 9<sup>TH</sup> OF APRIL 2016

NEW FOR 2016, MASTERCLASSES

COME ALONG AND SIT IN ON A FREE CLASS FROM SOME OF OUR BIG MANUFACTURER'S SUCH AS RECORD POWER, AND ROBERT SORBY.

FANTASTIC DEMOS IN WOOD AND CRAFTS PLUS TASTER SESSIONS IN OUR HOBBY MARQUEE, CHECK OUT OUR WEBSITE [WWW.YANDLES.CO.UK](http://WWW.YANDLES.CO.UK) FOR FURTHER DETAILS

TRADE STANDS WITH SPECIAL SHOW OFFERS

OUTSTANDING SELECTION OF TIMBER, WITH SPECIAL SHOW DISCOUNTS

VISIT OUR GALLERY, CAFÉ, HOBBY SHOP AND REFRESHMENT MARQUEE.

A PERFECT DAY OUT FOR EVERYONE, FROM THE PROFESSIONAL, TO THE HOBBYIST, TO THE FAMILY - DON'T MISS OUT - FREE ENTRY AND PARKING

**YANDLE & SONS LTD**  
 HURST WORKS,  
 MARCOCK, TA12 6RU  
 Tel: 01935 822207  
 e-mail: [info@yandles.co.uk](mailto:info@yandles.co.uk)

[WWW.YANDLES.CO.UK](http://WWW.YANDLES.CO.UK)  
 10am -5pm Friday  
 10am-4pm Saturday

# Engineered Precision



## Plane & Simple

TRP UL

The TRPUL's patented triple-blade drum delivers an impressive 45,000 cuts per minute for fast material removal and a superior finish to every project.

Traditionally the rebate depth for any planer is restricted by body design, however the TRPUL is designed with the blade drum positioned to the outermost edge, allowing unrestricted depth rebates right to the edge of the workpiece.

In addition, the removable blade drum system allows fitment of the sanding drum (both included) to convert the planer into a highly efficient sander.



**triton**  
Precision Power Tools

[tritontools.com](http://tritontools.com)

# What's new from



'THE' TOOL SPECIALISTS • WWW.DM-TOOLS.CO.UK • 0208 892 3813

## DCP580 18V XR CORDLESS BRUSHLESS PLANER

**MANUFACTURER:** DeWalt

**D&M GUIDE PRICE:** From £174.95

Arguably the most anticipated cordless tool from DeWALT has finally been announced and should be available from April – but is available to pre-order now!

The new DCP580 cordless planer is compact and well balanced and has a brushless motor for increased power and runtime. It has twin 82mm reversible blades for a smoother finish with a market leading 9.0mm rebate capacity and a 2mm depth of cut. The indexed fine adjustment dial, incorporated in the front handle, allows precision 0.1mm depth adjustment. It will be available either as a body only machine or with 2 x 5.0Ah 18V XR Li-ion batteries, charger and a case. Watch the preview video on the website.



## MAKITA 10.8V CXT SLIDE BATTERY SYSTEM

**MANUFACTURER:** Makita

**D&M GUIDE PRICE:** See website

Makita has launched a new 10.8V CXT Li-ion battery system together with a new range of associated cordless tools.

The new design slide-on batteries will be available in 1.5Ah, 2.0Ah and 4.0Ah capacities and as well as a higher capacity, feature individual cell monitoring, battery protection circuit, low temperature performance down to -20°C and a 4-stage LED capacity fuel gauge.

The new tools will include a combi drill, impact driver, circular saw and reciprocating saw, as well as a combi and two-piece impact driver kit.





BY ANDY STANDING

# Neat as a pin

**Andy Standing shows how to make a pegged mortise & tenon – a straightforward joint that utilises a pin to keep everything in place**

**P**egged, pinned or dowelled mortise & tenon joints are one of the earliest forms of the joint. They have the advantage of great structural strength without any reliance on glue. Also if no glue is used, the joint may be easily dismantled, if required, though on re-assembly a new pin may be needed. They can also be used for decorative effect by using a contrasting timber to make the pin. This is a straightforward joint to make, but care must be taken to place the pin correctly so that it pulls the joint tight, but also minimises any subsequent loosening due to timber shrinkage.

Both through and stub mortise & tenon joints may be pinned, but with a stub tenon, always make sure that the mortise is a little deeper than the length of the tenon to ensure a snug fit. [www](http://www.getwoodworking.com)



**1** Use a try square to mark out the position of the mortise on the mortise member, or stile



**2** Use the tenon member, or rail, to mark the precise width



**3** Choose a chisel whose width is close to one-third of the width of the stile, and use this to set your mortise marking gauge. Centralise the gauge and mark out the mortise. If cutting a through mortise, mark both sides. Put the gauge aside, but do not disturb the setting



**4** Mark out the tenon shoulder length on the rail using the try square. Carry the line on all round



**5** Using the mortise marking gauge as previously set, mark the tenon onto the rail. If the lines are very faint, run a sharp pencil along them to make them stand out more



**6** For faster waste removal on larger joints, it is worth boring some of it away with a drill. Select a bit size a little smaller than the width of the mortise and start by accurately drilling a hole at each end of the mortise, then remove as much of the waste in between with a series of overlapping holes. If you find it difficult to drill straight, stand a small try square on the workpiece to help guide you



**7** The majority of the waste is now removed ready for cleaning up



**8** Square up the edges of the mortise taking fine cuts with sharp chisels



**9** Now cut the tenon on the rail. Start by cutting the shoulders. Be careful to keep to the waste side of the marked line, and to stop before you cut into the tenon



**10** Stand the rail up vertically in a vice and cut down the tenon cheeks



**11** Mark out the position of the hole for the pin. It should be in the centre of the mortise, but as close to the rail as possible, while still leaving a reasonable thickness of timber to support the pin. If the hole is placed centrally on the stile, there is the chance that when the timber shrinks across the grain, the joint will become loose as the pin will no longer hold it. Bore the hole using a dowel bit, as this will cut a clean hole. Place a piece of waste timber in the mortise to minimise breakout and to keep the drill running straight



**12** Remove the waste and assemble the joint. Push the tenon in hard and place the dowel drill bit into the drilled hole and mark the tenon. Remove the tenon

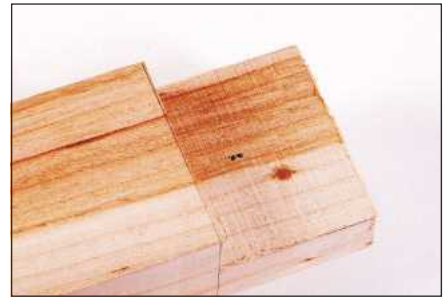

**13** Note the position of the mark made by the dowel bit on the tenon, then make a second mark about 1.5mm behind it towards the tenon shoulder. Centre the drill on this point and carefully bore through the tenon



**14** The two parts ready for assembly



**15** To make the pin you can use ready-made dowel rods or alternatively, it is easy to make your own. Take a short length of square, straight-grained hardwood and round off the corners with a sharp chisel. Work round it slowly taking care to keep it as round as possible. Taper the end so that it will easily fit through the tenon. Do not cut it to size, but leave generous extra length on both ends



**16** Assemble the joint and drive the pin into the hole with a hammer. The offset holes will pull the joint up tight. Support the back of the joint on blocks so that the pin can come right through



**17** Flush off the pin on both sides with a flexible dowel saw, or if you prefer, leave it slightly proud for a more rustic look



**18** The finished joint should look something like this

# DEWALT®

## PRECISION POINT™

### NEW

## HIGH PRECISION NAILING

The newly designed compact nose is 80% smaller than previous tools for improved access and visibility, ensuring that the fastener is driven with precision.

The innovative nose also detects the nailing surface minimising marking on the wood and making tool operation quick and effortless.



DNBDA15

32-64mm

**15 GAUGE FINISH NAILER**  
**DPN1564APP-XJ**



DNBSB16

25-64mm

**16 GAUGE FINISH NAILER**  
**DPN1664PP-XJ**



DNBT18

15-50mm

**18 GAUGE BRAD NAILER**  
**DPN1850PP-XJ**

**ALSO NEW: PORTABLE, SUPER QUIET,  
HIGH PERFORMANCE TWIN OUTLET COMPRESSOR**  
**DPC10QTC-GB**

- Almost half the noise of other DEWALT compressors
- High performance: 13.8 bar operating pressure
- Oil free pump and roll cage design for improved durability





BY COLIN SIMPSON

# Write on!

Colin Simpson takes us through the first stages of restoring a writing bureau back to its former glory

A few weeks ago a very sorry looking writing bureau arrived at my workshop in numerous pieces. Apparently the owner had asked someone to repair and rejuvenate it and that someone had taken it apart, before deciding that it wasn't a job he wanted to do. The owner asked if I could do something with it, stating that it wasn't very valuable, but she liked the size and proportions of the piece. I have to say that had it been a valuable antique, I probably wouldn't have touched it.

### The tambour

The whole bureau was very rickety with many loose joints, but I reasoned that when the back was replaced it would become far sturdier. There was a stuck drawer and the planks that made up the top were loose (**photo 1**). The automatic drawer locking mechanism (**photo 2**) also needed some work, but, by far the worst aspect of the desk was the roll top or tambour (**photo 3**). This came to me in four pieces and initially I wasn't sure that it was all there. The tambour



1 A very sorry looking bureau that arrived in pieces





**2**  
The simple but ingenious mechanism to lock the desk drawers



**3**  
The broken tambour came in four pieces with brittle and torn backing canvas



**4**  
Building a temporary frame to hold the tambour slats in place while I worked on it



**5**  
A wallpaper scraper could remove some of the perished backing...



**6**  
...but other areas needed a heat gun to loosen the glue



**7**  
I used a paint scraper to give the slats a final clean up until...



**8**  
...all the slats were like new. Note I have numbered them to keep them in the same order



**9**  
Securing the lightly stretched canvas to the plywood



**10**  
I applied two coats of contact adhesive to the canvas and the slats

looked as though it had been repaired several times in the past. Apart from the original, perished canvas backing, there was also a bitumen backed paper holding some of the slats in place and in other areas, old newspaper had been stuck down!

I decided to start the renovation with the tambour. I first screwed a batten to a piece of ply that was large enough to fit the whole tambour, then I rebated a couple of pieces of batten and screwed on at right angles to the first one. The rebate was just deep enough to accept the edges of the tambour's slats. The second rebated batten was screwed at right angles to the other end of the slats, **(photo 4)**. This framework held the tambour in place so I could work on it. Some of the backing came off easily, using a wallpaper scraper **(photo 5)** but other areas were more stubborn so I used a heat gun to gently soften the glue **(photo 6)**. To be honest this was a laborious task, but I had to go gently to avoid breaking any of the slats. When most of the backing layers and glue had been removed, I used a paint scraper to do the final clean-up of the individual slats **(photo 7)**. Two hours and a lot of elbow grease later, I had cleaned off all the glue from the slats and the lift rail **(photo 8)**.

### The canvas

Now to fix a new piece of canvas to them. I had originally planned to keep the slats in the framework I used to clean them, apply Titebond glue to the slats and stick the canvas to them. However, when I had cleaned the old backing from the slats, some of them moved and warped and I felt I would have great difficulty achieving a good, tight fit between each of the slats while the glue dried. I therefore decided to use contact adhesive. This would be less forgiving during assembly – you only get one chance – but I reasoned it would give me a better final result.

I removed the two rebated battens from the ply and laid some waxed paper over it to prevent the canvas sticking to the plywood. I then gently stretched the canvas over the wax paper and secured it with two battens screwed at 90° to the longer batten, using the lift rail as a spacer between them **(photo 9)**. I then gave both the canvas and the slats two coats of contact adhesive, allowing them to dry between coats **(photo 10)**. When the glue was just tacky I started to re-make the tambour. I started with the lift rail, carefully positioning it against the long baton **(photo 11)**. The slats were then stuck on, taking care to keep them in the original sequence. After gluing four or so slats I gave them each a good bash with a scrap

block and hammer to ensure they had good contact with the canvas (photo 12). When all the slats were in place, I removed the tambour from the frame and rolled it up to make sure that the slats were only glued to the canvas and not to each other (photo 13), then I put it aside to dry.

Once dry, I cut off the excess canvas with a sharp craft knife (photo 14) and cleaned up the ends of the slats that would ride in the grooves. I didn't want canvas in the grooves. The bureau had lost its lock and the owner asked me to fit a new one. I purchased one online, but it didn't quite fit the old recess. I made a few paring cuts with a sharp chisel to slightly enlarge the recess to get it to fit perfectly (photo 15).

### Staining

The tambour was now in one piece but the top sides of the slats looked very worn and dull (photo 16). The original stain had worn away completely in places so I decided to stain the tambour to unify the colour again. I used a dark oak gel stain that I brushed on (photo 17), left for a few minutes and then wiped off the excess. This unified the colour of the slats considerably and by wiping off most of the stain before it dried, the slats kept some of their original colour. When the stain had completely dried, I gave the tambour a couple of coats of wipe on polyurethane, from Minwax, followed by a coat of paste wax to give it a sheen. You can see the result in photo 18. 



11 Rebuilding the tambour, starting with the lift rail



12 Ensuring a good bond between the canvas and the slats with my trusty persuader



13 Here I am carefully rolling up the tambour to ensure the slats were not glued to each other



14 Cutting away the excess canvas using a sharp craft knife



15 Installing a new lock to the lift rail



16 Here is the tambour back in one piece but looking patchy and worn



17 I brushed on a gel stain, wiped off the excess and gave it a couple of coats of wipe on poly



18 The bureau is now looking in a much better state and ready for the next stage of renovation

### NEXT MONTH

With the tambour completed, Colin turns his attention to renovating the rest of the bureau. He'll show you how he did this next month...

# Machine Mart

**NOW 65 SUPERSTORES NATIONWIDE**

**WHERE QUALITY COSTS LESS**

### Clarke TABLE SAWS

FROM ONLY **£69.98** EX.VAT  
**£83.98** INC.VAT

LEG STAND KITS FOR CTS100 AND CTS111 ONLY £27.59 INC.VAT\*

INCLUDES LEFT & RIGHT TABLE EXTENSION

CTS100

MODEL	MOTOR	BLADE	EXC.VAT	INC.VAT
CTS600B	600W	200mm	£69.98	£83.98
CTS11	1500W	254mm	£139.98	£167.98
CTS100	1500W	254mm	£159.98	£191.98

### Clarke TABLE SAW WITH EXTENSION TABLES (250mm) CTS14

Ideal for cross cutting, ripping, angle and mitre cutting • Easy release/locking mechanism for table extensions • 0-45° tilting blade • Cutting depth: 72mm at 90° / 65mm at 45°

SHOWN WITH OPTIONAL LEG KIT CLK5 £19.98 EXC.VAT £23.98 INC.VAT

**£119.98** EXC.VAT  
**£143.98** INC.VAT

### Clarke RANDOM ORBITAL SANDER

**£29.98** EXC.VAT  
**£35.98** INC.VAT

- For sanding & polishing
- 125mm diameter sanding discs
- 4000-11000 rpm

CROS1  
INC 5 DISCS

### Clarke ELECTRIC POWER FILE

Variable belt speed • Tilting head

CPF13

FROM ONLY **£44.98** EXC.VAT  
**£53.98** INC.VAT

\*Black & Decker

MODEL	MOTOR	EXC.VAT	INC.VAT
CPF13	400W/230V	£44.98	£53.98
KA900E	350W/230V	£59.98	£71.98

### Clarke DUST EXTRACTOR/CHIP COLLECTOR

Powerful 750W motor • 56 litre bag capacity • Flow rate of 850M3/h

FROM ONLY **£129.98** EXC.VAT  
**£155.98** INC.VAT

METABO ALSO AVAILABLE

MODEL	MOTOR	FLOW RATE	BAG CAP.	EXC.VAT	INC.VAT
CDE35B	750W	450 M3/h	56Ltrs	£129.98	£155.98
CDE7B	750W	850 M3/h	114Ltrs	£149.98	£179.98

### Clarke POWER PLANERS

BLACK & DECKER

82mm cutting width

CEP1

MODEL	MOTOR	DEPTH OF CUT	EXC.VAT	INC.VAT
Clarke CEP1	650W	2mm	£23.98	£28.79
Einhell RT-PL82	850W	3mm	£49.98	£59.98
B&D KW750K - GB	750W	2mm	£57.99	£69.99

### Clarke HONEYWELL ELECTRIC HEATERS

Huge range of quality electric models - From DIY, trade to Industrial

DEVIL7003

FROM ONLY **£39.98** EXC.VAT  
**£47.98** INC.VAT

CZ-2104EV1

MODEL	VOLTAGE	HEAT OUTPUT KW	EXC.VAT	INC.VAT
CZ-2104EV1	230V	2.5	£39.98	£47.98
DEVIL 6003	230V	1.5-3	£49.98	£59.98
DEVIL 7003	230V	3	£54.98	£65.98
DEVIL 6005	400V	2.5-5	£74.98	£89.98
DEVIL 7005	400V	5	£79.98	£95.98
DEVIL 6009	400V	4.5-9	£119.00	£142.80
DEVIL 7009	400V	9	£137.99	£165.59
DEVIL 6015	400V	5-10-15	£179.00	£214.80

### Clarke QUALITY CAST IRON STOVES

OVER 22 QUALITY STYLES ON DISPLAY

POT BELLY 11.8kW 6.9kW

BARREL 209.00 EXC.VAT  
£250.00 INC.VAT

SAVE £60 inc.VAT

FLUES, COWLS & ACCESSORIES IN STOCK

PRICE CUT NOW ONLY **£199.00** EXC.VAT  
**£238.80** INC.VAT

WAS £298.80 INC.VAT

BUCKINGHAM 6kW

### Clarke CLAMPS

HUGE CHOICE OF SASH, SPRING, SCREW, SPREADER AND G-CLAMPS

UP TO 1800mm CAPACITY

FROM ONLY **£3.99** EXC.VAT  
**£4.79** INC.VAT

### Clarke HARDWOOD WORKBENCH

Includes bench dogs and guide holes for variable work positioning • 2 Heavy Duty Vices • Large storage draw • Sunken tool trough • LxWxH 1520x620x855mm

CHB1500

**£129.98** EXC.VAT  
**£155.98** INC.VAT

### Clarke WOODWORKING VICES

STANLEY Record

FROM ONLY **£13.98** EXC.VAT  
**£16.19** INC.VAT

VV7

MODEL	MOUNTING	JAW (WIDTH/OPENING /DEPT)mm	EXC.VAT	INC.VAT
Clarke CHT152	Bolted	150/152/61	£13.49	£16.19
Stanley Clamped	Clamped	72/60/40	£16.99	£20.39
Multi Angle Record V75B	Clamped	75/50/32	£19.98	£23.98
Clarke WV7	Bolted	180/205/78	£24.99	£29.99

### Clarke CORDLESS DRILL/DRIVERS

BOSCH Power Tools

Clarke CONTRACTOR

CON18Li

FROM ONLY **£36.99** EXC.VAT  
**£44.39** INC.VAT

PSR18

MODEL	VOLTS	BATTS	EXC.VAT	INC.VAT
CCD180	18V	1	£36.99	£44.39
CCD240	24V	1	£39.98	£47.98
Bosch PSR18	18V	1	£54.99	£66.99
CON18Ni	18V	2 x Ni-Cd	£59.98	£71.98
CON18Li	18V	2 x Li-Ion	£84.99	£101.99

### Clarke STAPLE/NAIL GUNS

All models include nail/staple pack and tough moulded case

CONSN18Li

FROM ONLY **£18.99** EXC.VAT  
**£22.79** INC.VAT

WAS £23.98 INC.VAT

SPARE NAILS / STAPLES IN STOCK

MODEL	TYPE	ELECTRIC	EXC. VAT	INC. VAT
CESN61*	Electric	22/18	£18.99	£22.79
CCT48	Cordless	4.8V Ni-MH	£24.99	£29.99
CESN62	Electric	18/18	£39.98	£47.98
CONSN18LiB	Cordless	18V Lithium-Ion	£99.98	£119.98

### Clarke BELT SANDERS

Ideal for surface removal, sanding and finishing

TRUKITA ABRASIVE SANDING BELTS IN STOCK

BS1

FROM ONLY **£29.98** EXC.VAT  
**£35.98** INC.VAT

MODEL	MOTOR	M/MIN	EXC.VAT	INC.VAT
Clarke BS1	900W	380	£29.98	£35.98
Clarke CBS2	1200W	480	£69.98	£83.98
Makita 9911	650W	75-270	£94.99	£113.99

### airmaster TURBO AIR COMPRESSORS

8/250 Superb range ideal for DIY, hobby & semi-professional use

HUGE RANGE OF AIR TOOLS IN STOCK

\*V-Twin

MODEL	MOTOR	CFM	TANK	EXC.VAT	INC.VAT
8/250	2HP	7.5	24ltr	£79.98	£95.98
7/250	2HP	7	24ltr	£89.98	£107.98
11/250	2.5HP	9.5	24ltr	£109.98	£131.98
8/510	2HP	7.5	50ltr	£119.98	£143.98
11/510	2.5HP	9.5	50ltr	£139.98	£167.98
16/510	3HP	14.5	50ltr	£209.00	£263.98
16/1010	3HP	14.5	100ltr	£259.98	£311.98

### Clarke ROTARY TOOL KIT

CRT40

FROM ONLY **£29.98** EXC.VAT  
**£35.98** INC.VAT

Kit includes: Rotary tool • 1m flexible drive • 40x accessories/consumables

### Clarke STATIC PHASE CONVERTERS

Run big 3 phase woodworking machines from 1 phase supply

Variable output power to match HP of motor to be run

PC60

FROM ONLY **£209.00** EXC.VAT  
**£250.00** INC.VAT

MODEL	MAX. MOTOR HP	FUSE	EXC.VAT	INC.VAT
PC20	2HP	10Amps	£209.00	£250.00
PC40	3.5HP	20Amps	£249.00	£298.80
PC60	5.5HP	32Amps	£299.00	£338.80

### Clarke CIRCULAR SAWS

Great range of DIY and professional saws • Ideal for bevel cutting (0-45°)

CON185

FROM ONLY **£34.98** EXC.VAT  
**£41.98** INC.VAT

\*Includes laser guide

MODEL	MOTOR	MAX CUT (mm)	EXC.VAT	INC.VAT
CCS185B	1200W	65/44	£34.99	£41.99
CON185	1600W	60/40	£54.99	£65.99
CS2	1300W	60/45	£59.98	£71.98

\*WAS £68.39 inc.VAT

### Clarke 4" BELT/6" DISC SANDER

Dust extraction facility • 4" x 36" belt tilts & locks 0-90° • 225mm x 160mm table, tilts 0-90° • 370W, 230V motor

CS4-6D

FROM ONLY **£84.98** EXC.VAT  
**£101.98** INC.VAT

### Clarke 6" BELT/9" DISC SANDER

Includes stand • 1HP 230V/1ph motor

CS6-9C

FROM ONLY **£209.98** EXC.VAT  
**£250.98** INC.VAT

### Clarke 1" BELT/5" DISC SANDER

Includes 2 tables that tilt & lock

CBS1-5

Quality induction 300W motor

FROM ONLY **£64.98** EXC.VAT  
**£77.98** INC.VAT

### Clarke 4" BELT/8" DISC SANDER

Includes two tables

CS4-8

550W 230V motor

FROM ONLY **£139.98** EXC.VAT  
**£167.98** INC.VAT

### Clarke DISC SANDER (305MM)

Powerful, bench mounted disc sander • 900W • No load disc speed: 1490rpm • 305mm Disc Dia. (1 x 60 grit sanding disc included) • Dust extraction port

CDS300B

FROM ONLY **£119.98** EXC.VAT  
**£143.98** INC.VAT

### Clarke SHEET SANDERS

CON300

FROM ONLY **£13.98** EXC.VAT  
**£16.79** INC.VAT

MODEL	SHEET SIZE	MOTOR	EXC.VAT	INC.VAT
CON200	190X90mm	150W	£13.99	£16.79
CON300	230X115mm	330W	£32.99	£39.59
Makita	112X102mm	200W	£54.99	£65.99

### Clarke PORTABLE THICKNESSER

Max thickness cap. 125mm and 250mm wide • Planing depths adjustable from 0-2.5mm • Powerful 1250W motor • 8000rpm no-load speed

CPT250

FROM ONLY **£189.98** EXC.VAT  
**£227.98** INC.VAT

### Clarke OSCILLATING BOBBIN SANDER

Provides exceptional finishes for deep & wide work pieces, front edges & narrow inner curves

Dust collection port • Inc. 6 sanding sleeves/bobbins • 330mm table height • 16mm oscillating stroke

COBS1

ONLY **£119.98** EXC.VAT  
**£143.98** INC.VAT

### Clarke BOLTLESS SHELVING BENCHES

Simple fast assembly in minutes using only a hammer

FROM ONLY **£29.98** EXC.VAT  
**£35.98** INC.VAT

SAVE 10% WHEN YOU BUY ANY MIX OF 5 FROM THIS RANGE SAVE AT LEAST £17.99 INC.VAT

CHOICE OF 5 COLOURS: RED, BLUE, BLACK, SILVER & GALVANISED STEEL

ALSO EXTRA WIDE INDUSTRIAL UNITS AVAILABLE

MODEL	DIMS WxDxH(mm)	EXC.VAT	INC.VAT
150kg	800x300x1500	£29.98	£35.98
350kg	900x400x1800	£49.98	£59.98

150kg (evenly distributed) Strong 9mm fibreboard shelves PER SHELF

350kg (evenly distributed) Strong 12mm fibreboard shelves PER SHELF

### Clarke PLANERS & THICKENERS

Ideal for DIY & Hobby use • Dual purpose, for both finishing & sizing of timber

CPT800

FROM ONLY **£169.98** EXC.VAT  
**£203.98** INC.VAT

MODEL	PLANING WIDTH	MAX THICK. CAPACITY	EXC. VAT	INC. VAT
CPT600	6"	120mm	£169.98	£203.98
CPT800	8"	120mm	£199.98	£239.98
CPT1000	10"	120mm	£269.98	£323.98

## Clarke 10" (254MM) SLIDING COMPOUND MITRE SAW

- For fast, accurate cross, bevel & mitre cutting in most hard & soft woods
- 1800W motor
- Laser guide
- 78mm max depth of cut

£129.98 EXC.VAT  
£155.98 INC.VAT

CMS10S2



FOR OVER **15,000** PRODUCTS INCLUDING **NEW Xtra** SPECIALIST TOOLS & MACHINERY visit [machinemart.co.uk](http://machinemart.co.uk)

**NEW 500 PAGE CATALOGUE** Over **1250** PRICE CUTS & NEW PRODUCTS



**GET YOUR FREE COPY NOW!**

- IN-STORE
- ONLINE
- PHONE

0844 880 1265



**TH-SM 2534**

- Quality Range of Mitre saws and blades in stock

MODEL	BLADE DIA/ BORE (mm)	MAX CUT DEPTH	EXC. VAT	INC. VAT
Einhell 2110	210/30	55/120mm	£56.99	£68.39
Evolution Fury 3	210/25.4	60/220mm	£119.98	£143.98
Einhell TH-SM2534	250/30	75/340mm	£159.98	£191.98
Makita LS1040	260/30	95/130mm	£199.98	£239.98



**Clarke CBM1B MORTISING MACHINE**

- Accurately creates deep square recesses
- Table size 150 x 340mm
- Max. chisel stroke 76mm
- Robust cast iron base & column ensures stability & accuracy
- 95mm depth of cut

CHISELS AVAILABLE FROM £8.39 INC VAT

...just and accurate with a good solid feel... Excellent value for money... See [www.machinemart.co.uk](http://www.machinemart.co.uk)



**Clarke TH-SB200 BENCH BANDSAWS**

MODEL	MOTOR	SIZE	EXC.VAT	INC.VAT
TH-SB200	180W	8"	£99.98	£119.98
CBS190	350W	7.5"	£114.99	£137.99

- Produce fast, precise mitre & longitudinal cuts
- Cuts in wood, plastic, etc.



**Clarke CBS300 PROFESSIONAL BANDSAWS**

Top Quality Bandsaws - ideal for professional workshop use. Strong steel body with solid cast iron table featuring induction motors

- Table tilts 45°
- Adjustable blade guide
- Supplied with stand, TPI wood cutting blade, rip fence, mitre guide, mitre gauge and push stick

MAGNIFIED MITRE GUIDE  
QUICK RELEASE FENCE  
DRIVE-BELT TENSIONING  
SOLID GROUND CAST IRON TABLE

£349.98 EXC.VAT  
£419.98 INC.VAT

£449.00 EXC.VAT  
£538.80 INC.VAT



**Clarke CDS-IV DETAIL SANDERS**

- Perfect for smooth and fine finishing along with hard to reach areas or curved surfaces

FROM ONLY £17.99 EXC.VAT  
£21.59 INC.VAT

ALL MODELS INC. SANDING SHEETS

MODEL	WATTS	EXC.VAT	INC.VAT
PS105	105W	£17.99	£21.59
RT-0S13	130W	£22.99	£27.59
CDS-IV	280W	£24.99	£29.99



**Clarke CFMSS1 FOLDING MITRE SAW STAND**

- Suitable for most sizes/makes of saw
- Inc. outriggers & rollers

PRICE CUT NOW ONLY £59.98 EXC.VAT  
£71.98 INC.VAT

NEW FOLDING MITRE SAW STAND IN STOCK - CONHW1 ONLY £119.98 INC VAT



**Clarke CDP152B DRILL PRESSES**

- Range of precision bench & floor presses for enthusiast, engineering & industrial applications

NEW RANGE

MODEL	MOTOR SPEEDS (W)	EXC. VAT	INC. VAT
CDP5EB	350 / 5	£59.98	£71.98
CDP102B	350 / 5	£69.98	£83.98
CDP152B	450 / 12	£119.98	£143.98
CDP202B	450 / 16	£199.98	£191.98
CDP10B	370 / 12	£169.98	£203.98
CDP352F	550 / 16	£199.98	£239.98
CDP350V	550 / 16	£219.00	£262.80
CDP502F	1100 / 12	£449.00	£538.80

B = Bench mounted  
F = Floor standing  
V = Variable speed



**Clarke CBS300 PROFESSIONAL BANDSAWS**

MODEL	THROAT DEPTH	MAX CUT 90°	MAX CUT 45°	EXC.VAT	INC.VAT
CBS300	305mm/12"	165mm	115mm	£349.98	£419.98
CBS350	340mm/14"	225mm	160mm	£449.00	£538.80

MODELS ALSO FEATURE:

- MULTI-STEP DUST EXTRACTION OUTLET
- REMOVABLE DUST TRAY
- FLEXIBLE LED WORKLIGHT
- BLADE TENSIONING CONTROL



**Clarke CJS380 JIGSAWS**

- \*DIY #Professional

MODEL	POWER (W)	DEPTH OF CUT (WOOD/STEEL)	EXC. VAT	INC. VAT
Clarke CJS380*	420W	55/6mm	£12.99	£15.99
Clarke CON750#	750W	80/10mm	£24.99	£29.99
Bosch PST700E*	500W	70/4mm	£44.99	£53.99
Einhell RT-JS 85	750W	85/5mm	£49.98	£59.98



**Clarke CSS16V SCROLL SAWS**

- 50mm max cut thickness
- Air-blower remove dust from cutting area
- Table tilts 0-45°

MODEL	MOTOR	SPEED (RPM)	EXC. VAT	INC. VAT
CSS400B	85W	1450	£69.98	£83.98
CSS16V	120W	400-1700	£79.98	£95.98
TH-SV405E	1200W	400-1600	£79.98	£95.98



**Clarke CMFT250 MULTI FUNCTION TOOL WITH ACCESSORY KIT**

- Great for sawing, cutting, sanding, polishing, chiselling & much more
- 250W motor
- Variable speed

£36.99 EXC.VAT  
£44.99 INC.VAT



**Clarke CR2 BOSCH ROUTERS**

- Powerful heavy duty machines ideal for trade and DIY use

CR2 INCLUDES 15 PIECE KIT WORTH OVER £20

FROM ONLY £39.98 EXC.VAT  
£47.98 INC.VAT



**Clarke CBG6SB BENCH GRINDERS & STANDS**

- Stands come complete with bolt mountings and feet anchor holes

STANDS IN STOCK FROM ONLY £37.98 EXC. VAT  
£47.98 INC. VAT

FROM ONLY £29.98 EXC.VAT  
£35.98 INC.VAT

6" & 8" AVAILABLE WITH LIGHT



**Clarke BJ900 BISCUIT JOINER**

- 11000rpm Operating Speed
- 860W Motor • 14mm Cutting Depth • Inc. dust bag and storage case

£49.98 EXC.VAT  
£59.98 INC.VAT



**Clarke CRT-1 ROUTER TABLE**

- Router not included

£59.98 EXC.VAT  
£71.98 INC.VAT

- Converts your router into a stationary router table
- Suitable for most routers (up to 155mm dia. Base plate)



**Clarke CWL325V 13" MINI WOOD LATHE**

- Ideal for enthusiasts/hobbyists with small workshops
- 325mm distance between centres • 200mm max. turning capacity (dia) • 0.2HP motor

£134.99 EXC.VAT  
£161.99 INC.VAT

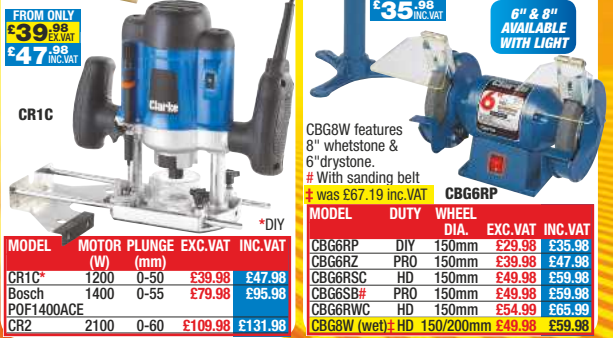

**Clarke CR1C ROUTERS**

MODEL	MOTOR (W)	PLUNGE (mm)	EXC.VAT	INC.VAT
CRTC*	1200	0-50	£39.98	£47.98
Bosch POF1400ACE	1400	0-55	£79.98	£95.98
CR2	2100	0-60	£109.98	£131.98

\*DIY

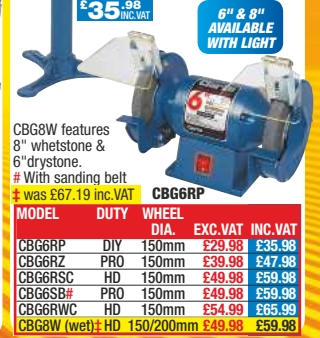

**Clarke CBG6RP BENCH GRINDERS & STANDS**

CBG8W features 8" whetstone & 6" drystone. # With sanding belt was £67.19 inc.VAT

MODEL	DUTY	WHEEL DIA.	EXC.VAT	INC.VAT
CBG6RP	DIY	150mm	£29.98	£35.98
CBG6RZ	PRO	150mm	£39.98	£47.98
CBG6RSC	HD	150mm	£49.98	£59.98
CBG6SB#	PRO	150mm	£49.98	£59.98
CBG6RWC	HD	150mm	£54.99	£65.99
CBG8W (wet) #	HD	150/200mm	£49.98	£59.98

## VISIT YOUR LOCAL SUPERSTORE OPEN MON-FRI 8.30-6.00, SAT 8.30-5.30, SUN 10.00-4.00

BARNSELY Pontefract Rd, Barnsley, S71 1EZ	01226 732297	EXETER 16 Trusham Rd, EX2 80G	01392 256 744	MIDDLESBROUGH Mandale Triangle, Thornaby	01642 677881
B'HAM GREAT BARR 4 Birmingham Rd, B'HAM HAY MILLS 1152 Coventry Rd, Hay Mills	0121 358 7977 0121 7713433	GATESHEAD 50 Lobley Hill Rd, NE8 4YJ	0191 493 2520	NORWICH 282a Heigham St, NR2 4LZ	01603 766402
BOLTON 1 Thynne St, BL3 6BD	01204 365799	GLASGOW 280 Gt Western Rd, G4 9EJ	0141 332 9231	NOTTINGHAM 211 Lower Parliament St.	0115 956 1811
BRIGHTON 123 Lewes Rd, BN2 3QB	01273 390962	GLoucester 221A Barton St, GL1 4HY	01452 417 949	PETERBOROUGH 417 Lincoln Rd, Millfield	01733 311770
BRISTOL 1-3 Church Rd, Lawrence Hill, BS5 9JJ	0117 935 1060	GRimsby ELLIS WAY, DN32 9BD	01472 354435	PLYMOUTH 58-64 Embankment Rd, PL4 9HY	01752 254050
BURTON UPON TRENT 12a Lichfield St, DE14 3QZ	01293 564 708	HULL 8-10 Holderness Rd, HU9 1EG	01482 223161	POOLE 137-139 Bournemouth Rd, Parkstone	01202 717913
CAMBRIDGE 181-183 Histon Road, Cambridge, CB4 3HL	01223 322675	HULL 746-748 Eastern Ave, HU2 7HU	0208 519 4286	PORTSMOUTH 277-283 Copnor Rd, Copnor	023 9265 4777
CARDIFF 44-46 City Rd, CF24 3DN	029 2046 5424	IPSWICH Unit 1 Ipswich Trade Centre, Commercial Road	01473 221253	SUNDERLAND 53 Blackpool Rd, PR2 6BU	01772 703263
CARLISLE 85 London Rd, CA1 2LG	01228 591666	LEICESTER 69 Melton Rd, LE4 2PNS	0113 231 0400	SHEFFIELD 453 London Rd, Heeley, S2 4HJ	0114 258 0831
CHELTEMHAM 84 Fairview Road, GL52 2EH	01242 514 402	LIVERPOOL 80-88 London Rd, L3 5NF	0151 709 4484	SIDCUP 13 Blackfen Parade, Blackfen Rd, SOUTHAMPTON 516-518 Portsmouth Rd.	0208 3042069
CHESTER 43-45 St. James Street, CH1 3EY	01244 311258	LONDON CATFORD 289/291 Southend Lane SE6 3RS	0208 695 5684	SOUTHAMPTON 1139-1141 London Rd, Leigh on Sea	01702 483 742
COLCHESTER 4 North Station Rd, CO1 1RE	01206 762831	LONDON 6 Kendal Parade, Edmonton N18	020 8803 0861	STOKE-ON-TRENT 382-396 Waterloo Rd, Hanley	01782 287321
COVENTRY Bishop St, CV1 1HT	024 7622 4627	LONDON 503-507 Lea Bridge Rd, Leyton, E10	020 8558 8284	SUNDERLAND 13-15 Ryhope Rd, Grangevont	0191 510 8773
CROYDON 423-427 Brighton Rd, Sth Croydon	020 8763 0240	LONDON 100 The Highway, Docklands	020 7488 2129	SWANSEA 7 Sarnet Rd, Lliansamlet, SA7 9AG	01792 792969
DARLINGTON 214 Northgate, DL1 1RB	01325 380 841	LONDON Unit 1, 326 Unstable Rd, LUTON LA 8JS	01582 728 063	SWINDON 21 Victoria Rd, SN1 3AV	01793 491177
DEAL (KENT) 182-186 High St, CT14 6BQ	01304 373 434	MAIDSTONE 57 Upper Stone St, ME15 6HE	01622 769 572	TWICKENHAM 83-85 Heath Rd, TW1 4AW	01925 630 937
DERBY Derwent St, DE1 2ED	01332 290 931	MANCHESTER ALTRINCHAM 71 Manchester Rd, Altrincham	0161 942 666	WARRINGTON Unit 3, Hawley's Trade Pk.	01942 323 785
DONCASTER Wheatley Hall Road	01302 245 999	MANCHESTER CENTRAL 209 Bury New Road M8 8DU	0161 241 1851	WIGAN 2 Harrison Street, WNS 9AU	01902 494186
DUNDEE 24-26 Trades Lane, DD1 3ET	01382 225 140	MANCHESTER OPENSHAW Unit 5, Tower Mill, Ashton Old Rd	01623 233 876	WOLVERHAMPTON Parkfield Rd, Bilston	01902 925251
EDINBURGH 163-171 Piersfield Terrace	0131 659 9919	MANSFIELD 169 Chesterfield Rd, South	01623 622160	WORCESTER 48a Upper Tything, WR1 1JZ	01092 474186

## OPEN 7 DAYS

4 EASY WAYS TO BUY...

- IN-STORE 65 SUPERSTORES
- ONLINE [www.machinemart.co.uk](http://www.machinemart.co.uk)
- MAIL ORDER 0115 956 5555
- CLICK & COLLECT

24868RH Calls to the catalogue request number above (0844 880 1265) cost 7p per minute plus your telephone company's network access charge. For security reasons, calls may be monitored. All prices correct at time of going to press. We reserve the right to change products and prices at any time. All offers subject to availability, E&OE.

# hapfo

Made in Germany

ULTIMATE WOODTURNING

## COMING SOON

### Hapfo 7000-CNC Woodturning Lathe



- > 3700mm between centres
- > Coping diameter 400mm
- > Centre Height 300mm
- > Weight - 1600kg

## G&S Specialist Timber

TOOLS AND MACHINERY

[www.toolsandtimber.co.uk](http://www.toolsandtimber.co.uk)

you can order online now



WE ARE EASY TO FIND:  
1 1/2 miles from the M6, J40.  
Take the A66 towards Keswick,  
turn left at first roundabout,  
follow the Brown Signs to  
The Alpaca Centre.

Open 8am to 5pm daily.  
10am to 5pm Saturday.  
Closed Sunday.

G&S SPECIALIST TIMBER

The Alpaca Centre, Snuff Mill Lane, Stainton, Penrith, Cumbria CA11 0ES.  
Tel: 01768 891445. Fax: 01768 891443. email: [info@toolsandtimber.co.uk](mailto:info@toolsandtimber.co.uk)

## the WoodRat<sup>®</sup>

is not just here for the dovetailing



WoodRat's Mortise Rail MR4 clocks in the length and position of any number of mortises. Each pair exactly placed on opposing stiles – simple, accurate and very quick!

see it in action - [www.woodrat.com](http://www.woodrat.com)

# Dowelmax

Tables, chairs, stools, kitchens, bedrooms, desks, bookcases, sideboards, beds, benches, doors, windows, steps, cabinets, **make them all and more with the Dowelmax Doweling Jig**

Dowelmax Doweling Jig -  
No need for biscuit jointers, tenoners, morticers, screws, loose tenons etc,  
**make joints faster, more accurately and stronger with Dowelmax**

The ultimate doweling jig for woodworkers!

See us on  and visit:

[www.dowelmax.co.uk](http://www.dowelmax.co.uk)

for more info, video and ordering.

 **Dowelmax** 

Tel: **01352 781168** or **07773 718758**

## AOB – a forum for woodworking matters

It's a pleasure for us here at *The Woodworker* to present this growing guide to timber suppliers in the UK. Remember, it's in all our interests to have such a resource at our fingertips, so if you know of any good suppliers of any kind of useful timber near you, then please get in touch and share it with all of your woodworking

colleagues. Who knows, you could be making a big difference to someone's special project! Just drop me an email if you'd like us to include anything in the magazine.

*Mark* [mark.cass@mytimemedia.com](mailto:mark.cass@mytimemedia.com)

### THE WOODWORKER TIMBER SUPPLIERS DIRECTORY, FEBRUARY 2016

**Adhectic Ltd**

**Tel:** 01235 520 738  
**Web:** [www.adhectic.co.uk](http://www.adhectic.co.uk)  
(Abingdon)

**A Harrison**

**Tel:** 01536 725 192  
**Web:** [www.aharrisonwoodturning.co.uk](http://www.aharrisonwoodturning.co.uk)  
(Northants)

**Bennetts Timber**

**Tel:** 01472 350 151  
**Web:** [www.bennettstimber.co.uk](http://www.bennettstimber.co.uk)  
(Lincolnshire)

**Black Isle Woodturning**

**Tel:** 07842 189 743  
**Web:** [www.blackislewoodturning.com](http://www.blackislewoodturning.com)  
(Scotland)

**Brodies Timber**

**Tel:** 01350 727 723  
**Web:** [www.brodiestimber.co.uk](http://www.brodiestimber.co.uk)  
(Perthshire)

**Brooks Brothers Timber**

**Tel:** 01621 877 400  
**Web:** [www.brookstimber.co.uk](http://www.brookstimber.co.uk)  
(Essex)

**D Emmerson Timber**

**Tel:** 01507 524 728  
**Web:** [www.emmersontimber.co.uk](http://www.emmersontimber.co.uk)  
(Lincolnshire)

**Earlswood Interiors**

**Tel:** 01564 703 706  
**Web:** [www.earlswoodinteriors.co.uk](http://www.earlswoodinteriors.co.uk)  
(Solihull)

**English Woodlands Timber**

**Tel:** 01730 816 941  
**Web:** [www.englishwoodlandstimber.co.uk](http://www.englishwoodlandstimber.co.uk)  
(West Sussex)

**Exotic Hardwoods**

**Tel:** 01732 355 626  
**Web:** [www.exotichardwoods.co.uk](http://www.exotichardwoods.co.uk)  
(Kent)

**EO Burton, Thorndon Sawmills**

**Tel:** 01277 260 810  
**Web:** [www.eoburton.com](http://www.eoburton.com)  
(Essex)

**Eynsham Park Sawmill**

**Tel:** 01993 881 391  
**Web:** [www.eynshamparksawmill.co.uk](http://www.eynshamparksawmill.co.uk)  
(Oxfordshire)

**FH Ives**

**Tel:** 01268 732 373  
**Web:** [www.fhives.com](http://www.fhives.com)  
(Essex)

**Fulham Timber**

**Tel:** 0208 685 5340  
**Web:** [www.fulhamtimber.co.uk](http://www.fulhamtimber.co.uk)  
(London)

**G&S Specialist Timber**

**Tel:** 01768 891 445  
**Web:** [www.toolsandtimber.co.uk](http://www.toolsandtimber.co.uk)  
(Cumbria)

**Good Timber**

**Tel:** 01327 344 550  
**Web:** [www.goodtimber.com](http://www.goodtimber.com)  
(Northamptonshire)

**Interesting Timbers**

**Tel:** 01761 241 333  
**Web:** [www.interestingtimbers.co.uk](http://www.interestingtimbers.co.uk)  
(Emborough)

**John Davis Woodturning Centre**

**Tel:** 01264 811 070  
**Web:** [www.johndaviswoodturning.com](http://www.johndaviswoodturning.com)  
(Hampshire)

**Joyce Timber**

**Tel:** 0208 883 1610  
**Web:** [www.joycetimber.co.uk](http://www.joycetimber.co.uk)  
(London)

**Lincolnshire Woodcraft**

**Tel:** 01780 757 825  
**Web:** [www.lincolnshirewoodcraft.co.uk](http://www.lincolnshirewoodcraft.co.uk)  
(Stamford)

**Ockenden Timber**

**Tel:** 01588 620 884  
**Web:** [www.ockenden-timber.co.uk](http://www.ockenden-timber.co.uk)  
(Powys)

**Olivers Woodturning**

**Tel:** 01622 370 280  
**Web:** [www.oliverswoodturning.co.uk](http://www.oliverswoodturning.co.uk)  
(Kent)

**Oxford Wood Recycling**

**Tel:** 01235 861 228  
**Web:** [www.owr.org.uk](http://www.owr.org.uk)  
(Abingdon)

**Stiles & Bates**

**Tel:** 01304 366 360  
**Web:** [www.stilesandbates.co.uk](http://www.stilesandbates.co.uk)  
(Kent)

**Scadding Timber**

**Tel:** 01179 556 032  
**Web:** [www.scadding-son-ltd.co.uk](http://www.scadding-son-ltd.co.uk)  
(Bristol)

**St. Andrews Timber & Building Supplies**

**Tel:** 01316 611 333  
**Web:** [www.standrewstimbersupplies.co.uk](http://www.standrewstimbersupplies.co.uk)  
(Scotland)

**Surrey Timbers Ltd**

**Tel:** 01483 457 826  
**Web:** [www.surreytimbers.co.uk](http://www.surreytimbers.co.uk)  
(Guildford)

**Sykes Timber**

**Tel:** 01827 718 951  
**Web:** [www.sykestimber.co.uk](http://www.sykestimber.co.uk)  
(Warwickshire)

**The Timber Mill**

**Tel:** 07966 396 419  
**Web:** [www.thetimbermill.com](http://www.thetimbermill.com)  
(Cornwall)

**The Wood Recycling Store**

**Tel:** 01273 570 500  
**Web:** [www.woodrecycling.org.uk](http://www.woodrecycling.org.uk)  
(East Sussex)

**Thorogood Timber Ltd**

**Tel:** 01206 233 100  
**Web:** [www.thorogood.co.uk](http://www.thorogood.co.uk)  
(Essex)

**Timberman**

**Tel:** 01267 232 621  
**Web:** [www.timberman.co.uk](http://www.timberman.co.uk)  
(Carmarthenshire)

**Waterloo Timber Ltd**

**Tel:** 01200 423 263  
**Web:** No website  
(Lancs)

**Wenban Smith**

**Tel:** 01903 230 311  
**Web:** [www.wenbans.com](http://www.wenbans.com)  
(Worthing)

**W L West & Sons Ltd**

**Tel:** 01798 861 611  
**Web:** [www.wlwest.co.uk](http://www.wlwest.co.uk)  
(Surrey)

**Yandle & Sons Ltd**

**Tel:** 01935 822 207  
**Web:** [www.yandles.co.uk](http://www.yandles.co.uk)  
(Somerset)

**IronmongeryDirect**
**MASTERS OF OUR TRADE**
**ORDER BY 8PM  
GET IT NEXT DAY!**
**FREE CATALOGUE Visit [IronmongeryDirect.com](http://IronmongeryDirect.com)**



TURNERS TOOL BOX  
DAVID MARTIN



# CREATIVE WELSH WOODTURNING LTD.

Turners Tool Box.Com

WOODTURNING – WOODWORKING – WOODCARVING  
TOOLS & ACCESSORIES

LOG ON TO:

[www.turnerstoolbox.com](http://www.turnerstoolbox.com)



Woodturning Chucks including the:  
Robert Sorby Patriot Woodturning Chuck  
Axminster Evolution SK114 Woodturning Chuck  
All with additional accessories making your time at the  
lather a more pleasurable experience



New  
Pen Mandrel Support



New

Bolt Action & Bullet Pen Kits  
In a variety of different metal finish's  
Including the required sized  
Drill bits & the bushing sets



Colt MaxiCut® Forstner Bits:  
Metric & Imperial Sizes



Colt HSS-M2 150mm Pen Drill Bits  
Sizes from 7mm upwards



DELIVERED WORLD WIDE

For more information Visit: [www.turnerstoolbox.com](http://www.turnerstoolbox.com)

Order online Open 24hrs – All at the click of a button and delivered straight to your door

Email: [info@turnerstoolbox.com](mailto:info@turnerstoolbox.com) – Tel: 01873 831 589 – Mobile: 07931 405 131



## The Rocking Horse Shop

Make a Unique Traditional Rocking Horse, 17 Superb Designs



Plans, books, DVD's,  
timber packs, accessories & fittings.

### Carving Courses

Whether you are an experienced carver  
or have never carved before, you will  
benefit enormously from one of our  
courses.



[www.rockinghorse.co.uk](http://www.rockinghorse.co.uk)

Tel: 0800 7315418

Fangfoss, YORK YO41 5JH



The puzzle also doubles up as a serviceable trivet for hot pans and plates



BY TONY SCOTT

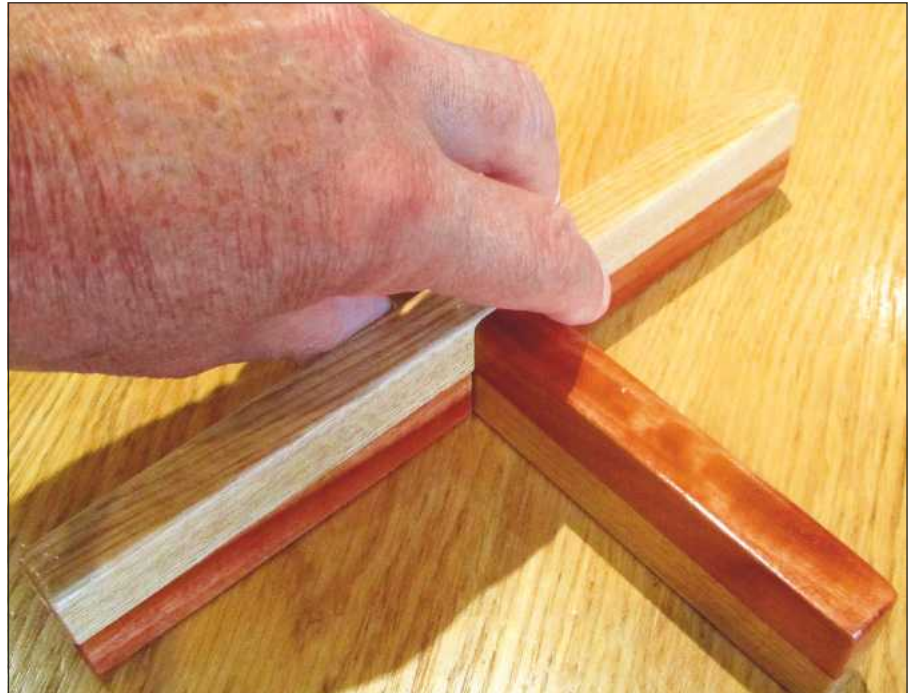

Centrifugal force releases the two halves without effort

# Child's play

Tony 'Bodger' Scott makes a puzzle for kids that baffles grown-ups

**L**ike all the best puzzles, this one is absurdly simple once you know the trick of it. It's also, with a little care, easy to make. And when you don't need a puzzle, you can use it as a trivet – a stand to protect your table or kitchen worktop from hot plates and pans.

## Preparation

Start by preparing strips of wood about 12mm square. From them cut four lengths of about 200mm each. The precise dimensions are not important, but it is helpful to have all four lengths the same. Trim 12mm off two of the lengths and cut the shortened lengths in half.

**1**  
Assembly is easier if all the lengths start out the same, but they don't have to be the same wood. My puzzle is made from offcuts of sweet chestnut and eucalyptus

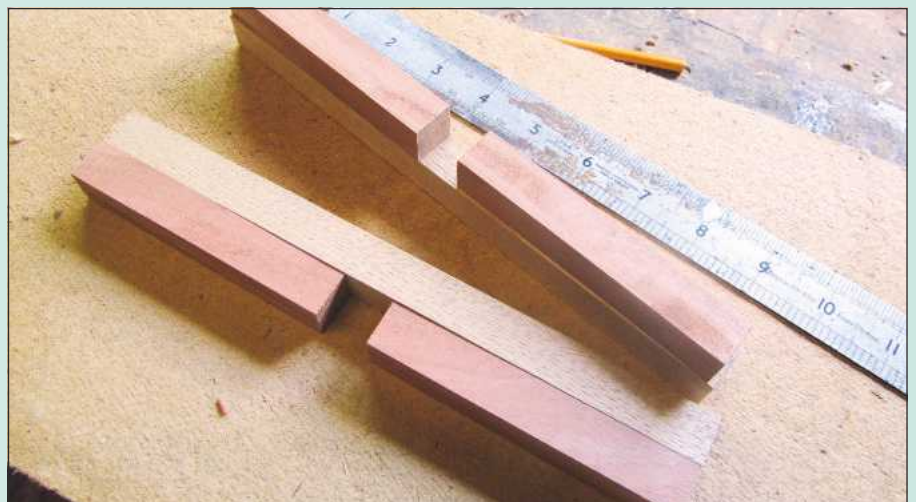



**2**  
A simple right-angled jig holds each strip reliably vertical

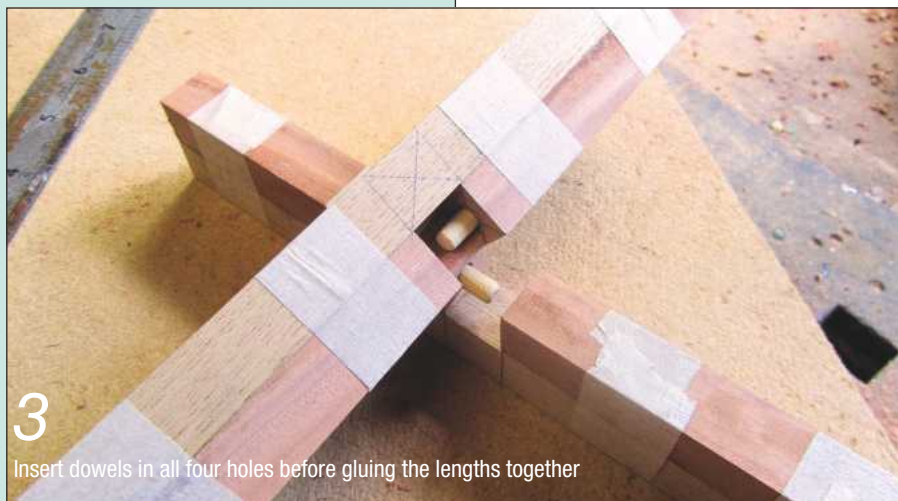

**3**  
Insert dowels in all four holes before gluing the lengths together



**4**  
Squares of masking tape protect the dowels from seepage



**5**  
Taken apart, the two halves can be kept in a drawer



**6**  
Each 50mm dowel needs to slide completely into its hole

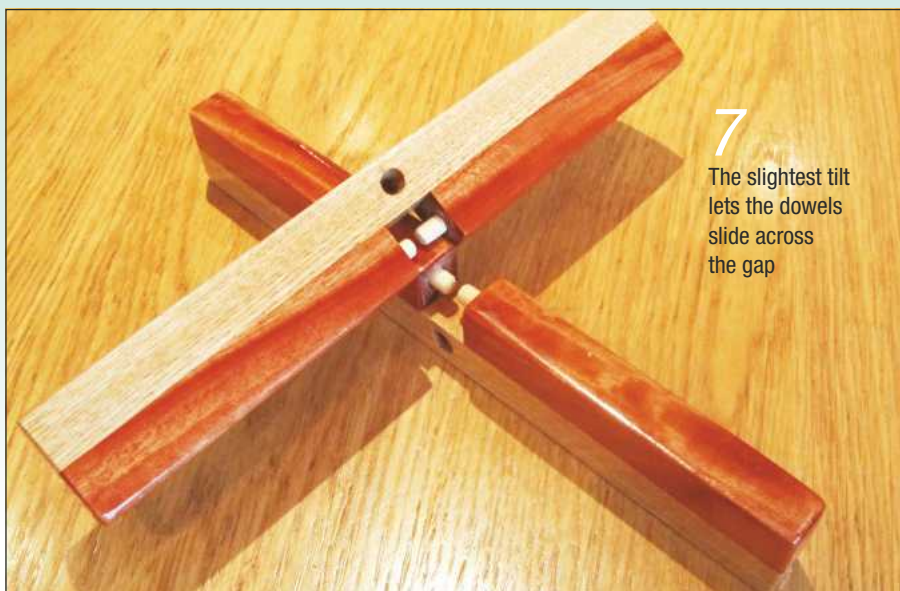

**7**  
The slightest tilt lets the dowels slide across the gap

Next, find or make some slim smooth dowel rod, and cut four 50mm long pieces from it.

### Drilling

Now for the stage that needs a little care. Using a drill bit fractionally larger than the dowels, drill holes into one end of each of your four shortened lengths. The holes need to be in the exact centre of each end and a millimetre or so deeper than each piece of dowel. The easiest way to get it right is to set up a tall fence and a depth stop on a pillar drill. Then, drop a dowel into each hole. Make sure it slides in and out freely and that its end sits inside the mouth of the hole.

Position the shortened lengths – 12mm apart and with the drilled ends facing each other – on to the uncut 200mm lengths. You should have, in effect, what looks like the two pieces of a halving joint.

### Assembly

Assemble the joint and mark the crossing points. Find the centre of each crossing – the spot in line with the dowel holes – and use the same drill bit as before to drill a hole right through. Make sure the dowels can slide freely into and through the central holes.

When you're happy that the holes align, and that the dowels slide freely and accurately across the gaps, drop the four dowels into their holes, glue the lengths into place, sand and finish.

### Solving the puzzle

To prepare the puzzle, push each dowel all the way into its hole, fit the two halves together and shake the assembly so that the sliding dowels lock the halves in place. Offer the assembled puzzle to friends and invite them to take it apart without force. No amount of tipping or tapping will solve the problem. But if you put the joint on to a smooth surface and spin it, centrifugal force will drive the four dowels out into their holes, and the two halves can be lifted apart without effort. As the meerkats say: 'simples!' 

# CMT ORANGE TOOLS™

Saw blades



Hole saws



Jig saw blades

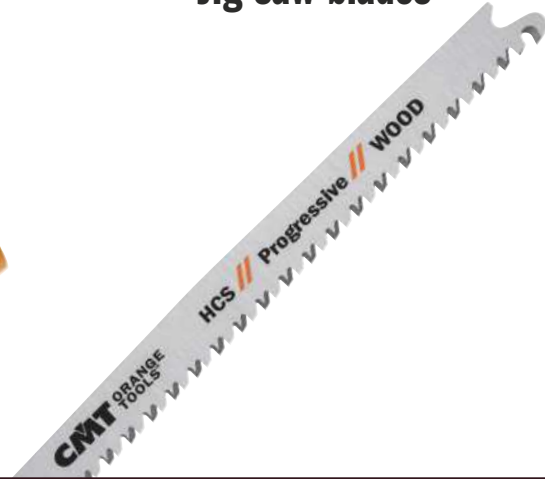

Sabre saw blades



Tools with bore & knives



Router bits & sets



## THE WIDEST TOOLING RANGE



For more information and to find your nearest stockist  
please visit [www.tomaco.co.uk](http://www.tomaco.co.uk)

# In brief...

## DIARY

### FEBRUARY

- 15** Pen making
- 18–19** Beginners' routing \*
- 24** Kitchen door/jointing
- 24–25** Beginners' woodturning (2 days)
- 25–26** Beginners' routing
- 26** Sharpening with Tormek woodturning \*
- 27** Fine-tuning hand tools \*
- 29** Turned boxes

\* Course held in Sittingbourne, Kent

Axminster Tools & Machinery  
Unit 10 Weycroft Avenue,  
Axminster  
Devon EX13 5PH

**Tel:** 08009 751 905

**Web:** [www.axminster.co.uk](http://www.axminster.co.uk)

**19–21** Make a step-up stool with Mark Cass

**21–24** Carving in wood – creative development for artists and makers

West Dean College  
West Dean, near Chichester  
West Sussex PO18 0QZ

**Tel:** 01243 811 30

**Web:** [www.westdean.org.uk](http://www.westdean.org.uk)

### MARCH

**1** Pyrography – Ben Beddows

**3–4** Beginners' woodturning (2 days)

**3–4** Introduction to milling

**4** Introduction to Leigh jigs

**7** Bandsaws

**17–18** Introduction to the small lathe

\* Course held in Sittingbourne, Kent

Axminster Tools & Machinery  
Unit 10 Weycroft Avenue,  
Axminster  
Devon EX13 5PH

**Tel:** 08009 751 905

**Web:** [www.axminster.co.uk](http://www.axminster.co.uk)

**19–20** Sussex Trug

making workshop

Weald & Downland

Open Air Museum

Singleton, Chichester,

West Sussex

PO18 0EU

**Tel:** 01243 811 363

**Web:** [www.wealddown.co.uk](http://www.wealddown.co.uk)

### MAKITA'S NEW CXT RANGE

Makita has launched a fresh 'CXT' range of 10.8V tools featuring a new slide battery as an addition to their current 10.8V tools featuring the cluster style batteries. The new 10.8V Lithium-ion slide battery, similar to the market leading 18V Li-ion battery used in the heavier tool range, has multi-contact terminals to ensure stable contact even under extreme work vibration conditions. The slide battery fits easily into the tools and new chargers and has the same high level of structural strength as well as having built-in protection to prevent overload or over discharging.

The tools are supplied with 2.0Ah batteries with a 4.0Ah version available as an optional accessory purchase. These new slide batteries have protection overload circuitry, will operate down to -20°C and have a four-stage LED fuel gauge indicator. Complete tools are delivered with the standard DC10WC charger while from the accessory range the DC10SA charger has a fan cooling system that cuts charging time to just 30 minutes for the 2.0Ah battery. The new 10.8V slide battery is fitted to the latest 'CXT' range of tools, which includes a combi drill, drill driver, impact driver, reciprocating saw and 85mm circular saw.

### DF031D drill driver

The new DF031D drill driver is a two-speed drill capable of driving a 10mm bit through steel and a 21mm bit in wood. The DF031D will run up to 1,700rpm, has 18 torque settings for fixing in addition to drilling; variable-speed control trigger and electric brake. The 1/4in hex chuck simply slides back to fit and lock the bit. Weighing 1.1kg with ergonomic soft grip, LED job light and belt clip, this compact but powerful drill driver is ideal for installation and precise assembly operations.

### TD110D 10.8V CXT impact driver

The new TD110D 10.8V CXT impact driver, now with 110Nm, has 20% more torque than its



predecessor and up to 3,500 impacts per minute, capable of driving an M10 high-tensile bolt. This outstanding power output can be attributed to the new motor design and also the direct drive from motor to chuck in this powerful tool. Weighing 1.2kg, and with similar features to the drill driver, all of the new 10.8V slide battery machines have full battery protection circuitry to protect the battery and the machine from overload stress.

### JR103D & JR105D reciprocating saws

The JR103D has tool-less blade change while the JR105D has screw fixing for the blade, which enables the jigsaw blades to be used. Both have 13mm length of stroke and run up to 3,300 strokes per minute enabling cutting of 50mm diameter pipe or 50mm-thick wood. All 10.8V tools are supplied with the new slide-type 2.0Ah batteries or as body-only units.

### HS301D CXT 85mm circular saw

The new Makita HS301D CXT 85mm circular saw can cut to 25.5mm deep, or to 16.5mm, at maximum 45° blade angle, which will run up to 1,500rpm. With narrow motor body and robust base frame this is a well balanced cordless circular saw ideal for all installation operations.

The latest two-piece 10.8V kits feature the impact driver paired with either the drill driver or combi drill, supplied together in a Makpac case with charger and two 2.0Ah batteries.

Prices start at £172, see

[www.makita.com](http://www.makita.com).

### KEEP RUST AT BAY

Developed by Boeing Aerospace to provide superior lubrication and rust protection in even the harshest environments, Boeshield T-9 Rust & Corrosion Protection Waterproof Lubrication spray is guaranteed to improve machine function while preventing rust on all bare metal surfaces. Because Boeshield T9 doesn't leave an oily film while providing lubrication for bare metal surfaces, it's ideal for use on lathe bed ways, table saws, drill press tables and jointer beds, just to name a few applications.

Protects all types of metal for months and is ideal for use on cast-iron equipment. It is also safe on paints, plastics, vinyls and contains no flouorocarbons, MEK, silicone, Teflon or Acetone. Prices start from £7 per can, see [www.woodturnerscatalog.com](http://www.woodturnerscatalog.com).





### KSS Circular Saw Series

The most comprehensive crosscut saw range in the world

Mafell AG have a full range of their Multi Function 5 in 1 saw systems to suit all requirements. From the KSS300 which is ideally suited to the flooring industry to the KSS60 & KSS80 which have a bigger depth of cut and are ideal for roofing and cutting Jack Rafter's easily & accurately.

All saws will allow the user to perform Cross-cuts, Mitres, Compound Mitres, Plunge cuts and Rip cuts.

Three models are also available as cordless versions.



The smart stop and adjustable fence allow the saw to be used for angle cuts from -60° to +60°



The highly graduated scale permits very precise angle settings



Model	Crosscut at 90°	Cutting depth at 90°	Cutting depth at 45°	Angle cuts	Available in Cordless
KSS300	300mm	40mm	27mm	-45° to +60°	Yes (18v)
KSS400	400mm	49.5mm	38mm	-60° to +60°	Yes (36v)
KSS60	408mm	61mm	47mm	-60° to +60°	Yes (36v)
KSS80	370mm	82mm	55.5mm	-60° to +50°	No

# A home for feathered friends

**John English shows you how to make an easy-clean home for birds using small scraps and offcuts**

**M**y workshop generates a fair number of small scraps, and using them to build birdhouses is a lot of fun. I use standard 110mm plastic sewer pipe for the body of the house, because it's impervious to weather and organic waste. In my design, when the perch is pulled out the body drops down for easy cleaning. The plastic pipe is just a hair shorter than the distance between the front and back of the birdhouse; this allows for venting, and also prevents binding. To mount the house, simply remove the pipe insert and screw the back to a wall, tree or post. One could add hook eyes and chains to the roof, too, but the wind would then rock it.

Building these wonderful little houses lets a woodworker create gifts with production line efficiency, while simultaneously cleaning out your workshop scrap bin.

## The front and back

Begin by making a template for each part, so that you can build as many birdhouses as you wish. Make a photocopy of the full-size patterns of the front and back panels and stick these to 18mm-thick stock using spray adhesive. You'll notice that the patterns in the photos are in inches, as I'm located in the United States, but the patterns provided here have been converted to millimetres for your convenience.



Bandsaw each panel to shape (**photo 1**), then clean up the curved edges on a drum sander – the ones that chuck into the drill press work well if a stand-alone oscillating version isn't available. Use a belt sander to dress the straight edges.

Chuck a 12mm bit in the drill press to create a perch hole in the front, and also one in the back, at the locations shown (**photo 2**). If the house is to be mounted by screwing it to a wall, tree or post, the hole in the back panel can go all the way through. The wall will act as a stop. If you're going to hang it with hook eyes and chains, only drill about two-thirds of the way through, or the perch might come loose in the wind.

Various bird species like different sized holes. The Royal Society for the Protection of Birds ([www.rspb.org.uk](http://www.rspb.org.uk)) publishes basic guidelines for woodworkers who wish to provide these rent-free homes for feathered friends. Their website also lists most British resident and migratory species, and provides a lot of information about each – including what they like to eat, in case you wish to add a bird feeder.

According to RSPB guidelines, the entrance hole size depends on the species you hope to attract:

- 25mm for blue, coal and marsh tits
- 28mm for great tits, tree sparrows and pied flycatchers
- 32mm for house sparrows and nuthatches
- 45mm for starlings

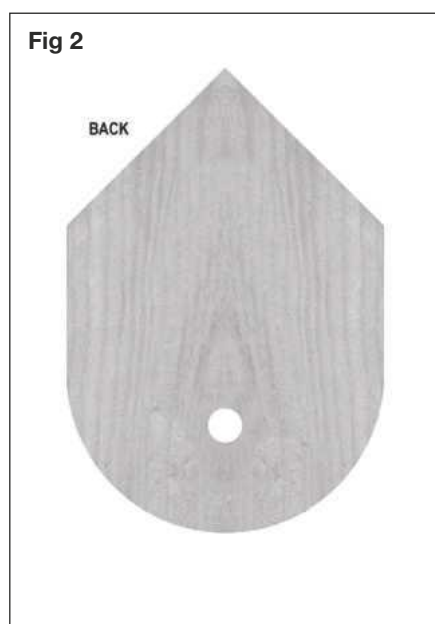
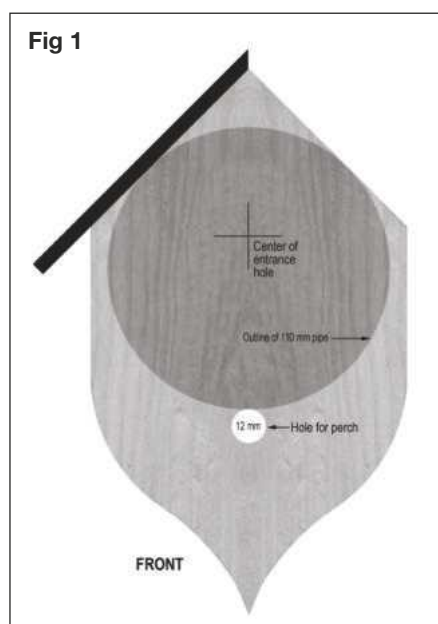



adhesive. When your fronts are all sanded (**photo 5**), choose a bird species and then chuck the appropriately sized bit in the drill press to bore the entry holes. Apparently, birds prefer that you don't round over the edges of this hole with a router bit, or sand it. Fussy, aren't they?

If you can't find thin stock, then you can re-saw standard boards to 7mm thickness for the roof. I do this safely by running the boards on edge across the table saw in two passes per edge, with the blade centred on the wood and set at about half height on the first pass. On the second pass, the blade height leaves maybe 10mm of material between the cuts (forming an 'H' when you

look at the end of the board). I then make the last little cut on the bandsaw, so the thin parts don't fall into the table saw blade, and clean up those kerfs on the planer/thicknesser or belt sander. Be sure the same face is against the table saw fence on every pass, so the cuts line up.

Cut the roof segments to length on the mitre saw, and switch to a chamfering bit and a router table fence (don't depend on a guide bearing as the edge is too thin) to chamfer one edge of each segment to 45° (**photo 6**). You could do this on the table saw, too. On the router table, be sure the fence is close to the bit (that is, leave a small opening), as the thin chamfered edge will need as much support as it can get. A plywood auxiliary fence works if your router table fences don't slide together to close the gap.

Next, cut the plastic pipe to length. I find the bandsaw is the quickest method, but a hand saw is probably safer. Draw a pencil line around its girth to guide you.

There are crosshairs on the pattern to centre the entry hole. I drilled the pattern with a small pilot bit (**photo 3**), so that I could use it to transfer the centreline to actual workpieces; this allows me to choose different sized holes and still use only one pattern. You may want to move the centreline up as far as possible for some species. And your PVC pipe may not exactly match the pattern, so be prepared to move the hole for the perch down a little bit if necessary. The fit between the perch and the pipe needs to be snug but not too tight, or it will be difficult to remove the perch when the house needs cleaning.

### Construction

Almost any natural timber species (hardwood or softwood) can be used to make the birdhouses. Some will last longer than others, but as there's no ground contact, almost any wood species will survive several nesting seasons. I would recommend air- or kiln-dried timber over green boards, as the latter have a tendency to warp, especially in sunnier locations. I used Western red cedar only because I had some. I was concerned that some birds might not like aromatic cedar, but they don't seem to mind at all, once it has weathered a little.

Use your pattern to lay out each front and back (**photo 4**), then cut, sand and drill as many fronts and backs as your scrap bin allows. If you're edge-gluing scraps to make boards that are wide enough to accommodate the pattern, use a weatherproof (rather than a water-resistant)

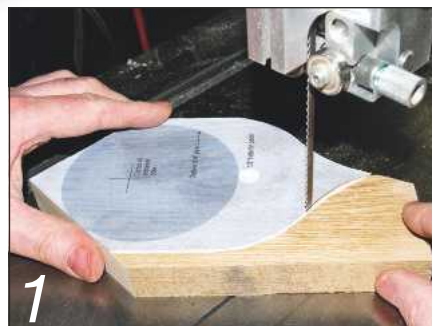

**1** Bandsaw each panel to shape, then clean up the curved edges on a drum sander



**2** Chuck a 12mm bit in the drill press to create a perch hole in the front, and also one in the back



**3** Drill the pattern with a small pilot bit



**4** Use your pattern to lay out each front and back

### BIRDHOUSE CUTTING LIST

All dimensions are in millimetres

Part	Qty	L	W	T
Front panel	1	18	120	206
Back panel	1	18	120	176
Roof segment	1	7	114	254
Pipe body	1	110	175	
Perch	1	12 dia.	254	



5 Next, choose a bird species and then chuck a bit in the drill press to bore the entry holes



6 Cut the roof segments to length, then chamfer one edge of each segment to 45°



7 Nail the first roof segment in place, aligning it with the rear edge of the back panel



8 Nail along the chamfered edge of the second roof section



9 Apply a little masking tape to the joint, just to hold things aligned until the front panel is installed



10 Lay the three washers inside and rest the plastic pipe on these



11 Nail the front panel in place



12 The completed birdhouse from the front...



...and the side view

## Assembly

Turn on the compressor, oil the brad nailer if it needs it, and load the gun with 35mm galvanised brads. If you're using a hammer and galvanised finish nails, have them ready. You should also have three large washers (all the same thickness) handy. Gently secure the back panel in a bench vice, and spread some waterproof glue on one of the top mitred edges. Nail the first roof segment in place, aligning it with the rear edge of the back panel (**photo 7**). Make sure the chamfered edge lines up with the top of the mitred edges. Just two nails will hold everything in place until the glue dries. Wipe off the excess glue, and then spread glue on the second mitred edge of the back panel, and also along the chamfered edge of the second roof section. Nail this in place, too (**photo 8**), then apply a little masking tape to the joint, just to hold things aligned until the front panel is installed (**photo 9**).

Remove the assembly from the vice and place it back-panel-down on the workbench. Lay the three washers inside and rest the plastic pipe on these (**photo 10**). Spread glue on the two mitred edges of the front panel and place this on top of the plastic pipe. Nail it in place (**photo 11**), and then immediately remove the pipe and washers – you don't want them to get glued in place.

Clean up any excess glue with a damp rag (don't forget to check the pipe, too). After the glue cures, sand the outside of the birdhouse but not the entry hole. No finish is actually necessary, but RSPB advises that softwood boxes can be treated with selected water-based preservatives that are known to be safe for animals, such as Sadolin ([www.sadolin.co.uk](http://www.sadolin.co.uk)). Apply it only to the outside of the box, and not around the entrance hole. Allow the finish to dry thoroughly before hanging the house, as the fumes may not be good for your new tenants.

Install the house by screwing the back to a building, tree or post. The latter is the best choice if dangerous critters such as cats are a problem, as a guard can be placed on the post to deter them. Pop the plastic pipe body in place, secure it with a length of dowel, and you're ready to run a 'for rent' ad in the local paper...

Many bird lovers warn against perches, while others think they're necessary to attract certain species. If you think they offer predators a podium, then simply make the exposed portion of your perch no more than a few millimetres long. This is too short for bullies to stand upon, but is still long enough for you to grasp when the house needs to be cleaned at the end of each nesting season. [www.getwoodworking.com](http://www.getwoodworking.com)



# Plana 3.1c • 4.1c • 6.1c Professional Planer / Thicknessers

## With optional slot mortising attachment

Scheppach have been manufacturing combined planer/thicknessers for more than fifty years! Scheppach Plana 3.1c (247x180mm) / Plana 4.1c (308x220mm) / Plana 6.1c (408x230mm) surface planing & thickening machines with optional mortising attachment continue the Scheppach tradition of offering many features which will guarantee the best finish of any similar machine including the patented feed system which eliminates indentation marks from the feed rollers.

Order any Plana Series machine specified below by close of business on 30th April 2016 and get a Scheppach Woova 3.0 FREE OF CHARGE (Woova 4.0 with Plana 6.1c) ensuring maximum extraction performance and a clean workshop environment in addition to superb planing efficiency.



Plana 4.1c shown with optional slot mortising att



**Woova 3.0 FREE**  
with Plana 3.1c & 4.1c  
RRP £399.00 inc VAT

**Woova 4.0 FREE**  
with Plana 6.1c  
RRP £750.00  
inc VAT



Woova 3.0 Extractor



Plana 3.1c shown with optional slot mortising attachment



Plana 6.1c shown in planing mode (with optional mortising att)



Plana 6.1c shown in thickening mode



Woova 4.0 extractor

Model	Planing / Thicknessing capacity mm	Price EXC/INC VAT Price includes extractor
Plana 3.1c Basic Machine + Woova 3.0 Extractor	247 x 180 mm	£1,291.67 / £1,550.00
Plana 4.1c Basic Machine + Woova 3.0 Extractor	308 x 220 mm	£1,745.83 / £2,095.00
Plana 6.1c Basic Machine + Woova 4.0 Ectractor	408 x 230 mm	£2,600.00 / £3,120.00
Slot Mortising Attachment for Plana 3.1c & 4.1c	N/A	£204.16 / £244.99
Slot Mortising Attachment for Plana 6.1c	N/A	£230.00 / £276.00

Scheppach planing machines have been sold and serviced in the UK by NMA since 1972. Go to [nmatools.co.uk](http://nmatools.co.uk) and see what users say about NMA unprecedented service. All prices Ex works, carriage extra. WE ARE MOVING. See below for our new address.



[www.nmatools.co.uk](http://www.nmatools.co.uk)  
Unit 1, Brookfoot Business Park, Brighouse, HD6 2SD

Phone: 01484 400 488  
Email: [sales@nmauk.com](mailto:sales@nmauk.com)

**FREE**  
160 page  
Catalogue.  
Available on  
request.



BY GORDON WARR

# Sunday best on show

Gordon Warr shows you an easy and effective means of displaying your favourite mugs and plates



**1** The full-size template

**T**here cannot be many households in the country in which one or more of the family is not a collector. Most of us have what is almost an instinct to pursue this pastime as a hobby with the nature of the objects collected being without limit. Judging by the number of dealers and auctions of old tools, this is one area of collecting where many woodworkers have a natural interest. But the hobby does not have to be confined to items from a bygone age; products of the present time are just as popular among collectors.

This display unit is designed to hold half

a dozen decorative plates of around 200mm in diameter, and the same number of mugs. If plates of 150mm diameter are displayed, then the unit will hold eight of this size. I used pine for the one described here, but was careful to choose prime quality virtually free of any knots. The white

faced hardboard used for the back helps to emphasise what is on display.

## The template

Start this project by making a full-size template of an end, using 6mm birch ply (**photo 1**). The template will be used for the actual profiling of the ends using the bandsaw and the router, and birch ply is ideal for this purpose. First, cut the ply to length and width, then mark on the positions of the four cross members. Lastly, draw in the curves, all using a pencil. It is important that the template is accurate in every way, with the curves being smooth and even (**photo 2**).

All the components for this project are 18mm-thick, with the widths varying. Note that the bottom shelf is 3mm wider than the other two; this allows for the rebate for the hardboard back. Next, hold the four cross members together in the vice, and mark to length (**photo 3**). This method ensures that they will all be the same. The fence on my bench saw does not cater for pre-set cross cutting above around 600mm, so I would have to mark out my curves later.

The two ends are likewise held together in the vice; these can be largely marked with the aid of the template. As well as the lengths, the centres for the kerfs for the biscuits can also be indicated (**photo 5**),

## PLATE RACK CUTTING LIST

All dimensions are in millimetres

Part	Qty	L	W	T
Ends	2	700	100	18
Top rail	1	710	80	18
Mid shelves	2	710	112	18
Lower shelf	1	710	115	18
Back	1	710	560	3

Widths and thicknesses are NET. An allowance has been added to the lengths. White faced hardboard or similar is required for the back

**Also required:** Two hanging plates, 25mm diameter

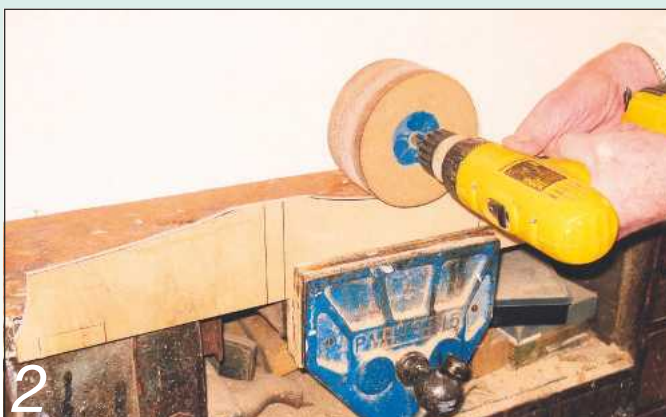

2

Smoothing the concave edges of the template



3

Marking out the length of all cross members while held in the vice



4 Transferring the shelf positions from the template to the ends



5 Cutting the slots for the biscuits



6 Forming kerfs for the biscuits in the ends of the cross members



7 Bandsawing the end components with the template and the bandsawing jig



8 With the template still in place, the edge is trimmed on the router table



9 Sanding the shaped edge of an end



10 Boring the top rail for the hanging plate



11 Forming a small cove cut to the edges



12 Holes for hanging plates completed and the bits used

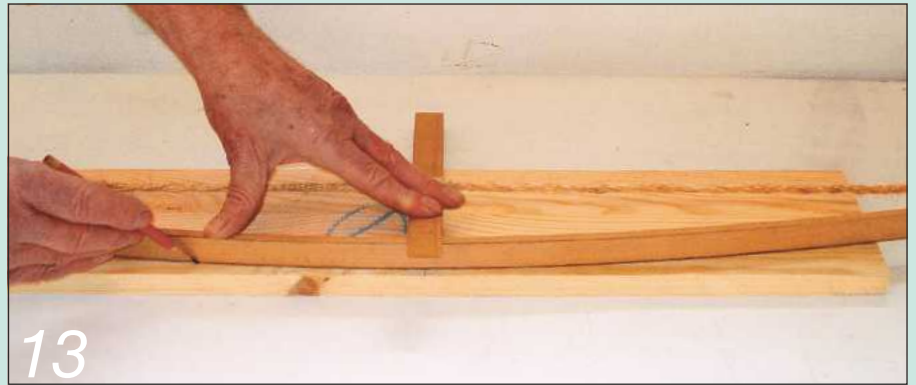

13 Using the tourniquet bow to mark the convex front edges of the shelves



14 Smoothing sawn edges of all three shelves using a compass plane



15 The cove cut to two of the shelves is also completed on the router table



16 The small coves at the edges are smoothed using a shaped sanding block



17 A corner of the rear rebate before squaring off



18 Trimming a corner of the rebate with a chisel

then the waste at the ends sawn off. The biscuits for the top rail are size 0 because of the restricted width of the ends (photo 5), and these can be formed with the help of the fence on the biscuit. With the remaining six kerfs, though, use a block of MDF cramped to the components to guide the jointer (photo 6). Make these kerfs for size 20 biscuits. You are now ready for forming the profiled front edges to the ends – the template will play a significant part here.

Make screw holes in the template to coincide with the centres of the cross members; these will allow for the template to be secured to the ends but without the

screw holes being visible later. The template now serves a dual purpose: first when sawing the curves to the front edge, then smoothing these sawn edges on the router. This is achieved on the bandsaw (photo 7) by using the sawing guide; this is fully adjustable so that the 'finger' on it is very close to the blade, for a finger which guides the template and thus guides the wood resulting in a uniform amount of waste being left on. This guide is made of metal, but is simple to make and was fully described in the April 2010 issue of *The Woodworker*. I stress, though, that it is not essential but nevertheless has proved to be extremely

useful. It is suitable for bandsaws with the main frame on the left or right. With the template remaining secured to an end, the final trimming of the front edge takes place on the router table using a roller guided straight cutter (photo 8). The template follows the bearing on the cutter and thus controls the final trimming, which will be flush with the edge of the template. Simple and effective, with both the ends being identical and with all edges trimmed. Final smoothing of the edges is completed using various bobbin sanders (photo 9). Because the top edge of the upper rail is shaped in a far simpler way



19 Flattening down between coats using an abrasive pad



20 The back drops into the rebate before being secured with small pins



21 Supported by a temporary pin, the positions of the holes are marked out

than the sides, the curves for these are marked and sawn separately, and also smoothed by bobbin sanders.

## The surfaces

At this stage, form the holes for the hanging plate on the rear surface of the top rail (photo 10). The hangers I used are the key hole type; these allow for hidden securing to a wall. First, bore a hole to match the diameter and thickness of the plates, then

bore overlapping holes of 12mm diameter and around 10mm deep within the larger hole to create space for the heads of the screws from which the unit will be suspended. The plates were not secured in place at this point in progress.

The next stage is to mark the curves on the front edges of the three shelves. This is completed using a bow, which can be adjusted for curvature by means of the tourniquet (photo 13). The waste is quickly removed on the bandsaw, then the three

pieces held together in the vice with cramps at the ends. First, use a compass plane to trim the surfaces into a uniform curve (photo 14), then smooth with a belt sander. Carefully allowing the sander to follow the curve is an excellent method of smoothing convex surfaces.



The completed project carrying six decorative plates and six mugs

Now it is back to the router. First, rebates need to be formed on the rear edges, those on the vertical components being stopped at both ends. Then, make cove cuts on the top surfaces of the upper shelves, and finally, make small cove cuts (photo 11) on the front edges of all six components.

## Cleaning up

With all the basic stages completed, you're now ready for cleaning up. For both the large and small coves, use shaped sanding blocks (photo 16) along with a 'flap' sanding drum held in a drill for the concave edges. For the remainder of the cleaning up, use a combination of a belt and orbital sander. At this stage, screw the hanging plates in place.

## Assembly

Now for the assembly, which has to be completed in one stage. Apply glue to all areas which comprise the joints, bring the parts together and apply the cramps. Introduce cramping blocks between the cramps and the work; these not only prevent any damage to the surfaces but also hold the cramps clear of the wood and thus prevent any risk of staining from the cramps. Check the assembly for being square and free of twist, then remove the surplus adhesive with a damp cloth. Once dry and with the cramps removed, trim the corners of the rebates square with a chisel (photo 18), then cut the hardboard for the back and trim to fit the rear of the unit.

## Finishing

A final smoothing with a fine grade of abrasive paper is always worthwhile; this allows for any soiling of the surface to be removed, and also for any sharp corners to be removed. The project is now ready for the finishing stage.

Because of the nature of this project, I advise using a polyurethane varnish. Polyurethane varnish is tough and hard wearing, and has very good 'flow' properties, which mean a uniform coating is readily achieved without any runs. Give it three coats, flattening down the first two (photo 19) but leaving the last straight from the brush. When thoroughly dry, pin the back in place (photo 20).

## Hanging

Just a couple of stages now remain, the first being to hang it to your chosen wall. Straightforward plugging and partial inserting of the screws are all that is required, leaving just one final job to be done. All you have to do now is decide which plates and mugs you want to display. [www](http://www.getwoodworking.com)



# Precisa 6.0VR Professional Precision Sawbench With FREE Patented Pre-Scoring Unit

The Scheppach Precisa 6.0VR precision cutting sawbench is the flagship model of classic circular sawbenches. Combining 110mm depth of cut for normal timbers with 2 metre guide rail to removable sliding table carriage \*\* (1.4mm capacity in front of sawblade); 1100mm width of cut; folding table width extension; patented pre-scoring system with separate motor and adjustable settings to within 1/10th mm accuracy no other sawbench in its class offers all the technological advantages incorporated in this superb sawbench.

Order a standard Precisa 6.0 before close of business 30th April 2016 and get the Precisa 6.0VR specification complete with patented pre-scoring unit. YOU SAVE £360.00 inc VAT



110 mm cutting height

Simply state  
**Order Online**  
Preferred Supplier

Precisa 6.0 complete package including Sliding Table Carriage & Table Width Extension

Precisa 6.0 Package 2 (P2)  
See price list for full details

**£2,590.00** EX VAT  
£3,108.00 INC VAT



### What they say:

"I looked at a number of other machines & seriously considered a \*\* which was £1000.00 cheaper but which is made in China. After considering all the quality & performance issues I chose the Precisa 6.0 & can assure you it is one of the best decisions I have ever made. It is worth every extra penny - and I mean that!"

Mr AC. Wilts.

\*\* Well known respected British brand name quoted but withheld by NMA.

**FREE!**



**Patented Pre-Scoring Unit**  
With integral motor  
**FREE OF CHARGE**  
SAVE £360.00 inc VAT

Offer ends 30th April 2016



Easy access to pre-scoring adjustment



Upgrade to sliding table carriage with articulated arm. Add £300.00 Ex VAT if ordered with the machine.



Micro fence setting scale to within 1/10th mm calibrations.



2 separate hand wheels for precise height & angle settings.

Scheppach circular sawbenches have been sold and serviced in the UK by NMA since 1972. Go to [nmatools.co.uk](http://nmatools.co.uk) and see what users say about NMA unprecedented service. All prices Ex works, carriage extra. WE ARE MOVING. See below for our new address.



[www.nmatools.co.uk](http://www.nmatools.co.uk)  
Unit 1, Brookfoot Business Park, Brighouse, HD6 2SD

Phone: 01484 400 488  
Email: [sales@nmauk.com](mailto:sales@nmauk.com)

**FREE**  
160 page  
Catalogue  
Available on  
request.



t: 01768 899895

# The Wood Workshop

**2016**  
**Course Dates now**  
**on our website!**

## Woodworking Courses in the beautiful Lake District

### Woodwork Course 1 (Tools and Things)

*A self-interest woodwork course where the aim is to give you the confidence and the knowledge to use basic hand tools and some of the more common power tools.*

You will be able to pick from a list of projects before you arrive that I believe you can complete in 5 days or less so that you will go home with one of them and you can proudly say "I made that".

I cover the teaching of how to handle tools by getting you started on your project and, as you need to use a new piece of equipment, I show you how. This means that the instruction is fresh in your mind and you do the task there and then.

On all courses there will only be a maximum of 4 at a time, this will mean that I will be available when you need help and advice.

### Woodwork Course 2 (Wood and Things)

*This is a continuation of course 1 (tools and things) with the emphases on timber, what are acceptable defects in timber and what isn't, how do you write out a cutting list that means something to your supplier, what to look for when buying wood and what to avoid.*

You will ideally have done course 1 (tools and things) or have a good working knowledge of how to use hand tools and have used hand held power tools.

The projects for you to pick from will be more complicated and will involve the use of the more sophisticated hand tools and hand held power tools and will include using some of the static power tools in the workshop. We will also be looking at buying timber, making cutting lists and drawing plans.

### Woodwork Course 3 (Project Days)

*The advanced course is rather different from the previous two.*

To come on this course you will need to have done both the other courses and have used your skill at home on your own projects and be ready to take on something more difficult.

### WoodRat Courses

*This course will teach you all the principles that you need to know!*

Visit our website for more information & updates on 2015/16 course information:

[www.woodworkshop.co.uk](http://www.woodworkshop.co.uk)

t: 01768 899895

e: [enquiries@woodworkshop.co.uk](mailto:enquiries@woodworkshop.co.uk)

**The Wood Workshop**

7-8 Redhills Business Park, Penrith,  
Cumbria CA11 0DT

[www.woodworkshop.co.uk](http://www.woodworkshop.co.uk)

## Distributors of the original RELAX workshop stoves



- Cast iron tops
- Superior air controls
- Unbeatable quality
- Range of 7 stoves
- Best workshop stoves on the market
- Still sold with a personal service

**Phone: 01889 565411**

Dovetails Industrial Estate, Uttoxeter ST14 8GA

Find us on Facebook "thehotspotuk" 

[www.thehotspot.co.uk](http://www.thehotspot.co.uk)





# Turn up your own accessories

**Ian Wilkie shows how you can save some pennies by turning your own regularly used workshop accessories**

If you have a lathe there are plenty of accessories you can make for yourself and this is very satisfying and economical. In this article I will explain how to make some of the items I find particularly useful and use regularly in my workshop. [www](#)

## SANDING DRUMS

### YOU WILL NEED

- Hardwood spindle blanks (beech, for example)
- A length of Pirelli rubber webbing, 50mm wide
- Lengths of 50mm wide (or wider) J-flex abrasive in various grits
- Contact adhesive and Copydex adhesive
- A pen turning mandrel or a home-made equivalent (see drawing)



Although sanding drums are readily available to buy, why not make your own and save some money? If you have a few hours to spare, turn up a batch of drums with a variety of diameters and lengths to suit the work you do and they will be ready to use when you need them. Each sander can have a different grit so that it is not necessary to stop work to put on a new sleeve, and when the abrasive is worn, it can easily be replaced with a new length

## SANDING DRUMS CONTINUED



2

Cut a blank of hardwood to suit the diameter and length of drum you are going to make

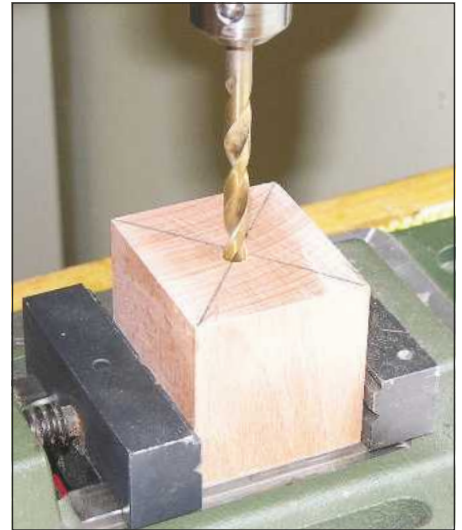

3

Mark the centre and drill a hole to match the diameter of the mandrel you are using. I am using a mandrel from Turners Retreat and this needs a 6.5mm diameter hole



4

The function of the mandrel is to hold the blank securely between centres while it is being turned. This particular mandrel can be extended to any length and then secured by a grub screw



5

Slide the blank on to the rod



6

Tighten the nut and bring up a revolving centre for support. The end of the mandrel rod is centre-popped for this purpose



7

Turn the blank to the diameter you require and check that the cylinder is parallel along its length



8

Remove the work from the lathe. Draw a line down the side of the drum and drill a small hole about one-third of the way in on the top surface. This will stop the wood splitting



9

Saw a slot along the line until it meets the hole



10

Cut a length of rubber webbing to go exactly around the circumference of the drum. This rubber acts as a cushion between the abrasive and the wood and allows a little 'give'. If you cut Pirelli webbing at right angles with sharp scissors, it will not fray. This webbing has a number of uses in the workshop and can be purchased by the metre from online upholstery suppliers. Glue the rubber to the surface of the wood with contact adhesive



11

Measure and cut a length of J-flex abrasive with a little extra so that the ends can be pushed into the slot. Apply Copydex adhesive. The advantage of this glue is that it is easy to peel off the abrasive when it needs replacing without damaging the rubber underneath. J-flex abrasives can be purchased by the metre in a number of grits; the brown is suitable for hardwoods and the yellow for softwoods. I have put coloured dots on the top of each sander so that I can readily identify the size of the grit



12

Cut a slither of wood or plastic, shape it to a wedge and hammer it into the slot to hold the ends of the abrasive firmly in place



13

A sanding drum can be held in the headstock of a lathe for sanding and shaping. Use the pen mandrel to hold the sanding drum in the chuck or make a few of your own as I describe overleaf



14

A drum can also be used in a dedicated drill press or with an electric drill in a stand

## DIY MANDREL

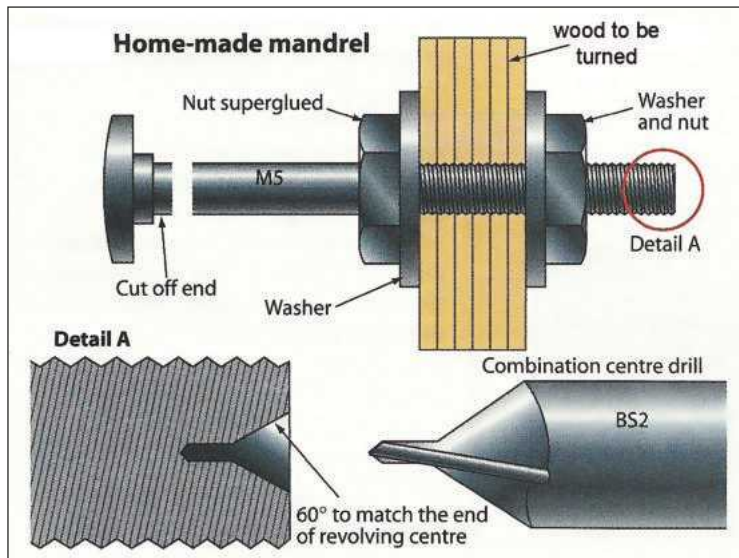

Take a 5mm (M5) coach bolt with a plain shank and threaded end and cut off the head with a small hack saw. Screw on a nut up to where the plain shank starts and glue it into position with CA adhesive. Hold the plain shank end in a drill chuck in the headstock and fit a second drill chuck in the tailstock with a centre drill (BS2). Drill the end of the shank to produce a 60° hole to support the tapered side of a revolving centre. The centre drill produces a 2.2mm pilot hole followed by a countersunk hole. The pilot hole ensures that there will be no damage to the revolving centre point. To use, place a metal washer on the mandrel followed by the blank to be turned and then thread on a second washer and finally a nut to hold the blank firmly. Bring up the tailstock with a revolving centre to support the end of the mandrel shank

## GLUE CHUCKS



Glue chucks are very useful for holding small blanks and for holding short lengths of irregular branchwood. They can be cleaned off and used over and over again. Turn a piece of hardwood to the round between centres and form a spigot to suit the chuck jaws you are going to use or a spigot to fit into a drill chuck. Remount in the chuck and face off the surface to make it true and flat. Work can be attached to a glue chuck

with contact adhesive, hot-melt glue or, for light work, heavy-duty double-sided carpet tape. I particularly favour hot-melt glue because it is very quick to set and three equally spaced small blobs will give a really good grip. It is easy to prise the work off the chuck when it has been turned and any residual glue can be cleaned off so that the glue chuck is ready to be used again



The glue chucking method is particularly suited to small work because the diameter can match the blank and there is good clear access for the turning tool

## THICKNESSING JIG

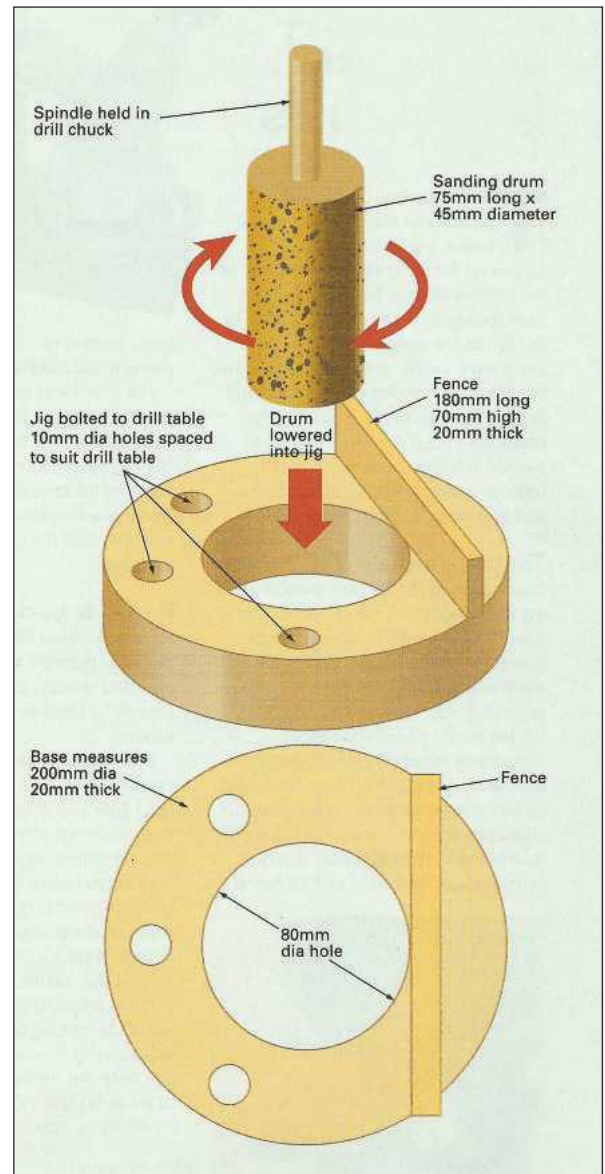

A drum sander mounted in a bench drill used with a home-made jig can offer a very effective and not too expensive way of thicknessing small strips of wood. The sanding drum is held in the bench drill and the wood is passed between the fence on the jig and the sanding drum repeatedly until the required thickness is arrived at. The drawing above gives details for making your own wooden thicknessing jig. The jig is designed to fit any size bench drill and the 10mm diameter holes can be spaced to suit a specific drill table. The distance between the outside of the drum and the fence is adjusted by swivelling the table, while the hole in the centre enables the drum to be lowered slightly below the lever of the jig. Do not press the wood against the drum but let the abrasive do the work and aim to remove only a small amount with each pass. Make sure the piece of wood being put through the sander is at least 300mm long as short pieces are difficult to handle and always check that the permanently fitted fence is at right angles to the base. The jig is most commonly used with a proprietary sanding drum but it will work equally as well with a home-made drum

## SANDING DISCS



For many years I used a disc like this to hone up my small turning tools and it works well

All new lathes come with a small faceplate, which is often put aside and not used very often. It is a simple matter to cut a 125mm diameter disc from thick plywood or MDF, to true up the edge and screw it on to the faceplate. Glue a standard sized 125mm aluminium oxide-type abrasive disc to the surface of the disc using contact adhesive or hold it with double-sided carpet tape. To get the best use out of the sanding disc, make a simple table with a stem to fit in the toolrest holder as shown here. It is an advantage if the stem is made from metal and you will probably find something suitable if, like me, you squirrel away 'useful' things in an odd-box! Take care to make sure the table is at right-angles to the disc so that wood can be trued up accurately. Sanding will produce lots of dust but if you have an extractor, it is not too difficult to make an attachment to remove as much of the dust as possible at source

## PRESSURE PADS

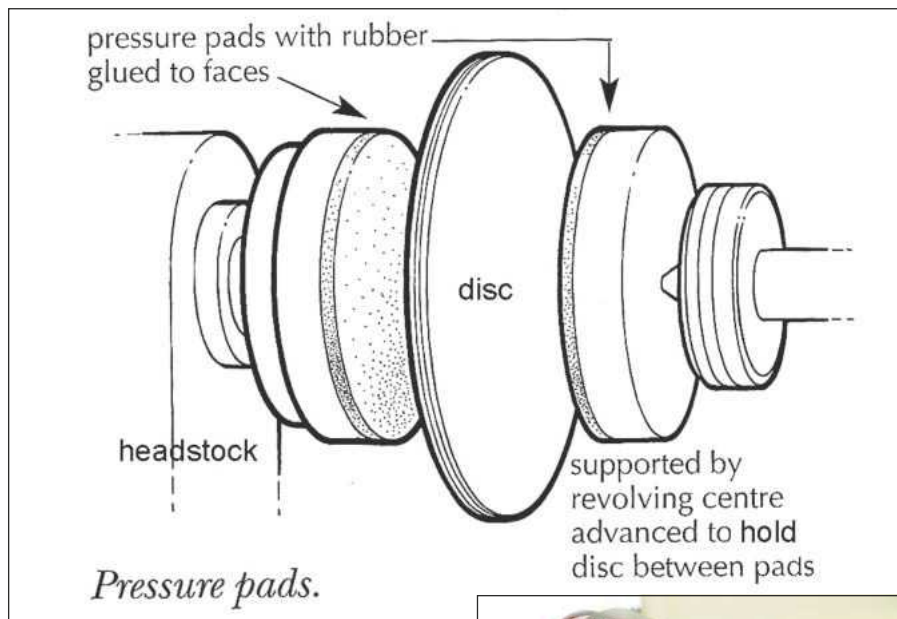

Make two pads from thickened hardwood. Mark out two circles and cut them roughly to the round. Screw the first one to a faceplate and turn it to the diameter required. Glue rubber to the surface; this is another example where Pirelli webbing can come in handy. Take the second blank and centre pop on one side. Countersink the centre pop to match the point of a revolving centre. Position the second blank so that it is in contact with the rubber face of the first blank and bring up the tailstock to hold it firmly in position. Turn the second blank to match the first. Release the tailstock pressure and glue rubber to the un-popped surface



This is a method I frequently use when I want to hold thin discs of plywood or thickened hardwood to turn or tidy up the edge without marking either surface

## A DEDICATED DRILLING JIG



A jig for drilling holes of a specific size round the circumference of a piece of wood can be turned from a cylinder of hardwood with a spigot to suit the toolrest holder. Hold the jig in the lathe to determine where the hole needs to be and drill it accurately. A metal tube tapped over the wooden spigot and a short length of metal tube of the correct diameter inserted in the drilled hole is an advantage for greater accuracy



This jig, used with a small electric drill and an indexing system, can be used for drilling accurately spaced holes



[www.norfolksawservices.co.uk](http://www.norfolksawservices.co.uk)

Visit us on-line or in-store for a comprehensive selection of woodwork machinery, power tools & consumables from all the top brands



[www.facebook.com/norfolksawservices](http://www.facebook.com/norfolksawservices)



@Norfolksaw

Norfolk Saw Services, Dog Lane, Horsford, Norwich NR10 3DH

Tel: 01603 898695 E-mail: [sales@norfolksawservices.co.uk](mailto:sales@norfolksawservices.co.uk)

Protect and enhance the natural beauty of wood with Treatex Hardwax Oil



Table designed and built by Jim Sharples Furniture



  
**treatex**<sup>®</sup>  
Naturally superior wood finishes

### Treatex Hardwax Oil

protects and enhances the appearance of all types of internal wood surfaces including floors, stairs, doors, furniture and worktops. Treatex Hardwax Oil is manufactured on a base of natural sustainable raw materials: jojoba oil, linseed oil, sunflower oil, beeswax, candelilla wax and carnauba wax.

- Brings out the timber grain
- Adds warmth to wood
- Easy to apply
- Quick drying
- No sanding required between coats
- Low odour
- Resistant to spills of water, wine, beer, coffee, tea and fizzy drinks
- Withstands high temperatures
- Very durable
- Easy to clean and maintain
- Spot repairable
- Safe for use on children's toys

tel: 01844 260416  
[www.treatex.co.uk](http://www.treatex.co.uk)

# In your own write...

Here are just a few of the latest letters we've received since the last issue. Drop us a line on paper or via screen and keyboard to add your voice to the woodworking crowd; you might be one of the lucky few who will manage to get their hands on a coveted *Woodworker* badge!

## SNAIL MAIL OR EMAIL?

You can write to us at *The Woodworker*, MyTime Media Ltd, Enterprise House, Enterprise Way, Edenbridge, Kent, TN8 6HF or send an email to [mark.cass@mytimemedia.com](mailto:mark.cass@mytimemedia.com)



## TOOLBOXES

Hi Mark,

I noticed in the article 'get the skills', in the January edition (see *WW* Jan page 17) a reference to: "drawers or pull-outs in such a way to be instantly to hand."

I made my toolbox over 50 years ago while I was a student teacher at Shoreditch College of Education – nothing original or eye catching, simply drop down sides and a single narrow drawer. Recently, I have made four similar boxes for my grandsons, and am saving up to kit out these boxes with tools.

The problem with this design is that many of the larger tools sit on top of one another, and have to be moved to find the chosen one, together with minor damage caused. Perhaps a future article in your excellent magazine could address this problem, and suggest some suitable solutions?

Regards, **Mike F**

Hi Mike,

*I think we all like a toolbox, and I can't remember when we last had one in the mag. I shall see what can be done about this as it's one of my favourite projects, too. And if any other readers out there have their own versions, I'd love to see them. Just email a photo to the usual address.*

*Mark*

## MORE BIER?

Dear Mark,

I read Eric Kwiatkowski's letter (January 2016) with great interest. I have been a long-time friend of Robin Stretton – Dr Samuel Stretton's grandson. He is quite elderly and frail in hospital at present. He has family books that may shed further info, which may be of interest to Eric.

I would be grateful if you could forward this to Eric and ask him to contact me and send me his article on Dr Stretton, which I am sure would be very much appreciated by Robin.

Many thanks, **Chris Burton**

*Consider it done, Chris. We're only too happy to help.* **Mark**

## WHICH BLADE?

Mark,

I'm setting up my workshop and am picking up a new table saw in a few weeks' time. It's a bit of a monster and should last a lifetime, but currently doesn't have a blade. I may have got a bit carried away and can probably only afford one for now so was thinking of a multi purpose 40-ish tooth type.

Any recommendations on which brands I should go for? It's quite a nice machine so seems a shame to put a mediocre blade on it, but I've not really got a clue which one to get.

**Bon Norman**

Hi Bon,

*There are plenty of blades on the market, and fortunately most of them are pretty good, what with improving manufacturing standards and all. Front runners at the moment are IRWIN who have a wide selection for just about any machine you can think of, and they're made in Italy by a long established specialist blade manufacturer.*

*Next time you're at your local tool supplier, they'll be glad to have a chat about them, but often it will be the sizes (blade diameter and bore) you need to fit that will be the limiting factor. It's very important to keep your blades sharp, regardless of quality, so if you can stretch to it, try and get two so you can always have the other one being sharpened.*

*Good luck with it all, and let me know how you get on.* **Mark**



IRWIN offer a comprehensive range of table saw blades, all of which are of excellent quality

## WORKSHOP WILDLIFE

Hello Mark,

I always enjoy receiving my copy of *The Woodworker* and particularly your 'Editorials' – thank you.

When in my workshop, I prefer to work with the door open. A 'friend' also seems to like it that way and takes it as an invitation to pop in and see what I'm up to! See attached photo of my 'friend'.

Kindest regards,

**Norman Gilbert**

*Well that's just great, Norman! The only time I had a bird in my workshop was a panicky fly-through by some kind of sparrow or something. Truly your workshop must be a place of calm and delight. Thanks for sharing it.*

**Mark**

*P.S. If any other reader has a photo of livestock in their workshop, I'd love to see it!*



Norman's workshop helper!

Here at *The Woodworker* we're always pleased to see photos of your work, and we know everyone else is as well! So send them in now and see if you can make the cut.



# The altar of ambition

**A tailor-made bench that suits your needs and preferences, says Tony Sutton, reflects your woodworking aspirations**

**S**ome 20 years ago, when I first became seriously interested in woodworking, I began by making furniture for the house. Money was tight, so I used melamine-covered chipboard held together with dowels and screws, and worked on a cheap copy of the famous Black & Decker workmate in a cold, damp single garage at the end of the garden. My early skills, on the other hand, came from my father, who was a cabinetmaker and later a carpenter too, so my school holidays had been spent helping him in the workshop and on site, where I gradually learned about his craft.

This apprenticeship stood me in good stead, and it wasn't long before I outgrew the folding bench and made my first 'real' workbench: a piece of 19mm MDF that was attached to the garage wall along its back edge, and supported at the front by two pine legs.

Looking back, the things I made may have been pretty poor, but I was very proud of them at the time, and through their making I developed my skills, advanced to using solid woods, and discovered the joys of a well-tuned hand plane, sharp chisels and a reasonable quality handsaw. Another workbench followed, this time made from yellow pine, hinged at the back and with removable front legs so that it could be folded down every evening to make room in the garage for the car!

By the time we moved house last year, my woodworking needs had changed again: I was working almost exclusively with hardwoods, and to a standard that I felt justified the dedication of the new garage to service as a workshop. The heart of any workshop, of course, is the bench. I'd go so far as to say that, in being tailored to your particular needs and preferences, your ideal bench will reflect your woodworking aspirations. My own skills have developed, for instance, to a point where I only use

## SOURCING MATERIALS

Yandles in Martock – [www.yandles.co.uk](http://www.yandles.co.uk) – is my preferred woodyard, as they generally sell wood from sustained and managed forests and their prices are very competitive. They also plane one side of each plank so you know what your finished project will look like. For this project, I bought a nice pile of steamed beech for the top, and enough air-dried English oak for the trestle. The wood I used is plain-sawn stock; quartersawn would have been preferable but, being a relatively wasteful cut, it's more expensive



When I started working almost exclusively with hardwoods and hand tools, I felt the need for a new workbench that would suit my needs and practises. The result was this oak and beech bench with its custom-made tail vice

I found to my pleasant surprise that the bench top only needed a couple of passes with the plane to make it flat. It's finished with boiled linseed oil

power tools for rough dimensioning; the majority of my joinery and all my finishing is done with hand tools. This approach calls for a strong flat datum surface on which to work. With the acquisition of my new workshop, then, came the need for a new bench.

### Design considerations

I decided to build the bench from beech and oak in the common European form, not least because the mass afforded by this design is optimal for using hand tools. I also followed tradition in positioning a face vice on the left-hand of the bench, and having a tail vice to hold stock flat against the top to facilitate hand planing. In the past, I'd found having a face vice mounted on the end of the bench to be an unsatisfactory arrangement. However, as I was undecided whether to use a traditional European style L-shaped tail vice or Veritas' twin-screw type, I elected to build the bench and decide on the tail clamping method later!

The key areas in which I chose to deviate from the traditional design were the front apron, the tool tray, and the bracing of the trestle. The front apron of the bench is

90mm deep and 90mm wide to provide a very solid and rigid work area for chiselling and sawing; it also offers a wide surface area onto which work can be clamped. The bottom of the tool tray, meanwhile, lifts out in four sections to facilitate easy rear clamping of workpieces, too.

As my new workshop is essentially a single garage, space is at a premium, so I need to be able to store tools under the bench. Thus the rear of the trestle has two rails, while the front has only an upper rail, allowing portable machinery to be fitted underneath when not in use. I can't see that I'll be moving any time soon, so I decided to make the construction of the trestle using traditional joinery techniques rather than knock-down methods. As a result, all joints are wedged mortises; several also use draw-bored dowels (see page 14) to provide additional rigidity and stability.

Footprint aside, perhaps the most critical dimension in a bench is the working height. Research revealed that while the tops of most proprietary benches are between 830 and 970mm high, in order to hand plane



The substantial boards for the bench top were glued and cramped...



...and a tenon was formed on either end using a router and guide



The front left-hand corner of the apron was reinforced using dovetail joints



A beech offcut was used to make the face for the face vice



The construction of the tail vice laid bare



Clean up the shoulders and faces using a shoulder plane and rabbet plane

boards comfortably, my 5ft 8in frame calls for a working height of just 870mm.

## Construction: sizing up

To start with, all the boards were run through the planer/thicknesser to take them close to their final dimensions. I took care to remove the same amount of material from both sides of all boards to avoid movement after machining, and removed very little material from the 55mm-thick beech boards so as to retain as much thickness as possible for the top. With the machining out of the way, I planed all surfaces square with a jointer (mine is fitted with a fence), and then smoothed all surfaces using a No.4½ smoothing plane.

## The bench top

As the wood had been lying in the workshop for a couple of weeks since machining to dimension, I hand planed the sides square and also planed a little hollow along their length to allow for future shrinkage as the wood dries out over the years. The boards were then glued up and clamped. Once dry, I ran a 12.7mm router against a clamp guide across the top and bottom of each end to form a tenon; the overhang at the ends was then removed with a circular saw.

The boards for the apron were cut to length, and slots were routed in the end pieces to receive the tenons on the bench

ends; a set of asymmetrical dovetails were also cut to join the front and the left-hand side piece, giving extra strength to the wide apron. The front was then glued to the bench top, while the side pieces were bolted in place using 8mm coach screws rather than glue so as to allow for movement in the timber across the bench's width. With the apron in place, I fitted the face vice to a block of beech that was glued and screwed to the underside of the bench top.

## The tool tray

To form the ends of the tool tray recess, I cut two lengths of 50 × 155mm beech at 45° on one end, and glued them to the rear of the bench top. I then glued a 25 × 100mm plank of beech across these blocks to form the rear of the tool tray; two pieces of 20 × 10mm beech fitted under the top on either side of the recess provided a lip to support the tray's 4mm MDF bottom.

The underside of the bench was now pre-finished with a couple of coats of linseed oil; once dry, the top was fitted to the trestles using eight 8mm coach screws driven through the upper cross-brace at either end. Believe it or not, flattening the bench top took just a couple of passes with a jointer plane. The top was then finished with five coats of boiled linseed oil, though for water-resistance Danish oil might have been better.

## BENCH DOGS

After finishing the top, I drilled holes for bench dogs using a portable drill stand that was clamped in place. The advantage of round holes is that the dogs can rotate to sit squarely against board ends, whatever their angle. The dogs themselves are made of wood to protect my plane blades in the event of accidental strikes, and are quickly turned up on the lathe; their 40mm square tops provide good support for the workpiece, and are made in a variety of thicknesses to suit different jobs



I also fitted a pair of recessed metal dogs at one end of the bench for extra versatility

The wooden jaw for the face vice was made from a piece of beech 50 × 155mm, with a routed recess in the back made using the vice itself as a template; this was simply secured using a couple of screws.

### The tail vice

During the build I'd settled on a traditional tail vice for the right-hand end of the bench, and had ordered the hardware from Axminster for the princely sum of £12 plus postage.

The jaw runs in a guide that was made by routing a slot in an offcut of beech, which was then screwed onto the face of the bench top recess. The jaw itself was roughly cut to shape from a 50mm-thick piece of beech and then fine-tuned using hand planes and chisels. The aim here was for a close sliding fit between the small tenon and the slot in the bench top as any play here will be exaggerated in the final vice. The remaining tail vice parts were cut from the remains of the 50mm beech, and joined at either end using dovetails of the same pattern used on the apron. Once assembled, I cut a slot in the vice face piece that sits under the bench top so that it could ride along a plywood guide piece. The vice hardware, meanwhile, was mounted by drilling a clearance hole in the rear of the vice and through the right-hand side of the apron.

The total cost of materials for this bench was under £200, including the two vices; the build time came to just 10 days. To buy a bench of comparable size might have cost anything from £800-£1,800, so I made



The tapers in the upper cross-brace mortises were cut with the help of an angled guide...



...that were driven in and trimmed back once dry



... while the tenons were cut ready for the mahogany wedges...



The lower cross-brace used draw-boring to ensure a tight joint

a saving, and have a bench that I can really call my own.

### The trestle

My design called for a lower cross-brace between the front and rear legs at the floor. As the garage floor surface is uneven concrete, however, I raised this brace by making some feet from a 25mm-thick oak board cut at 45° on the inner end. These were glued, clamped to the brace and left to dry.

The upper and lower cross-braces were mortised using a hollow chisel mortiser and a 12.7mm mortise chisel for cleaning up. The tenons on either end of the legs, meanwhile, were marked out and the shoulder cuts made using the sliding table on my Kity table saw; the face cuts were made slightly over-size using the bandsaw. The shoulders and faces were then cleaned up and trimmed individually using a shoulder plane and a rabbet plane to fit their respective mortises.

The next step was to cut the sides of the mortises in the upper cross-brace with a 5° taper that sloped away from the tenon faces. This taper would allow the tenon sides to open out when I secured them using mahogany wedges during construction. To cut the taper, I made an angled guide block, which was clamped in place to

support the chisel's back during the cut. A simple hand-sawn kerf around 10mm in from either side of the tenons is enough to accept the wedge. As an engineer, I think that stress relief's good; I drilled a 4mm hole at the bottom of each cut.

For the lower joints, I felt that wedging the tenons was unsuitable; instead, I opted for draw-boring, ensuring a very tight fitting shoulder on the tenon, and a very strong joint. To this end, I drilled a 12mm-diameter hole through the cross-brace, located centrally in the mortise sides. A similar hole was drilled in the tenons, offset towards their faces by a couple of millimetres so as to pull the tenon tight against the cross-brace when a 12mm dowel was driven through.

The legs were now cut with the mortises for the longitudinal braces, and some mahogany wedges prepared. A liberal coating of glue was then applied around the tenons. The wedges were driven home and the whole assembly was left to dry – no clamps required! Once cured, the protruding parts of the wedges were cleaned off.

The longitudinal braces were cut to length, and wedged tenons were prepared on their ends. These were then glued into the legs and, owing to its size, the assembly was clamped up until dry. Once again, the ends of the wedges were trimmed with the smoothing plane. [www.getwoodworking.com](http://www.getwoodworking.com)



The tool tray

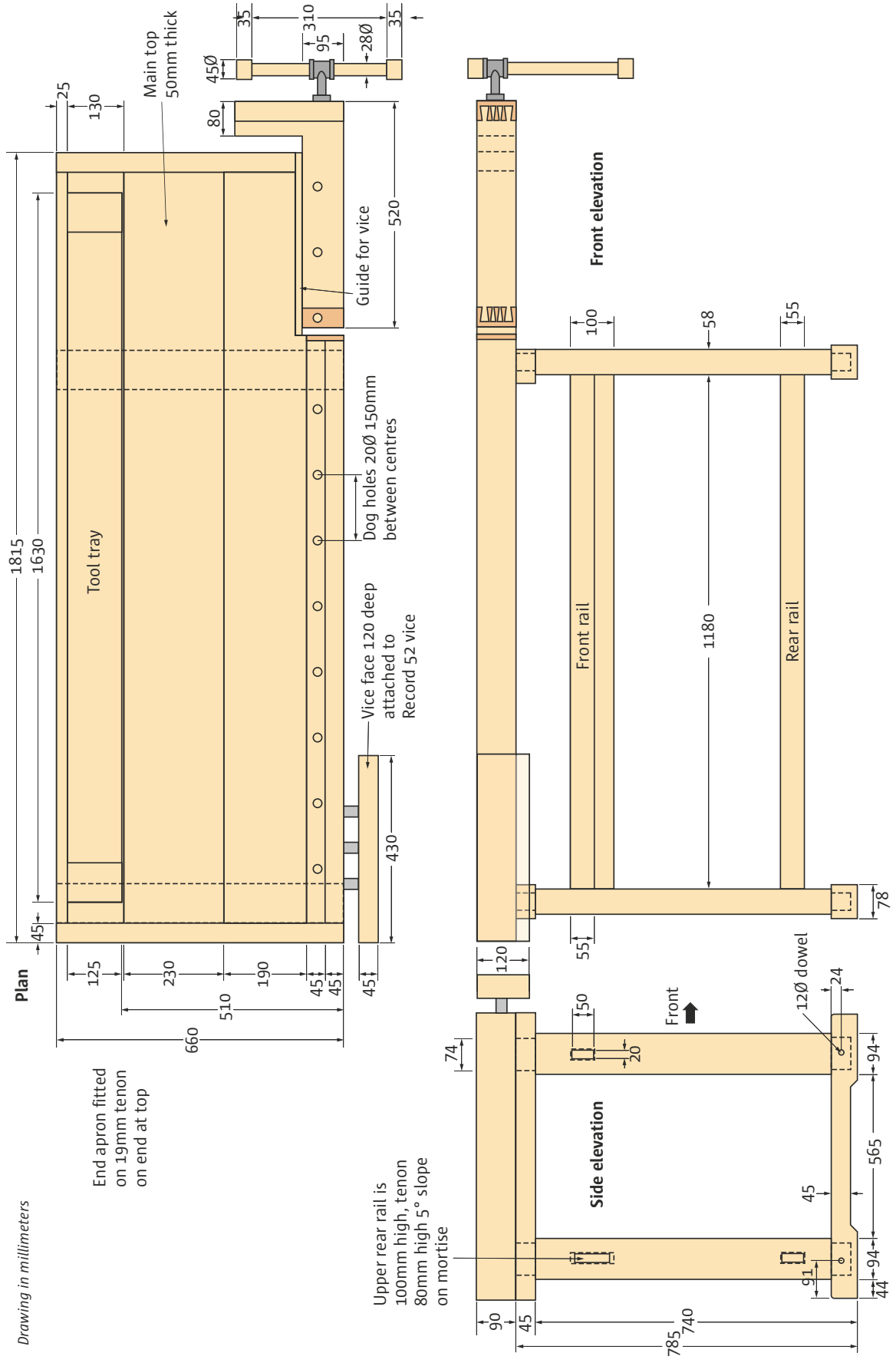

Drawing in millimeters

**Details**

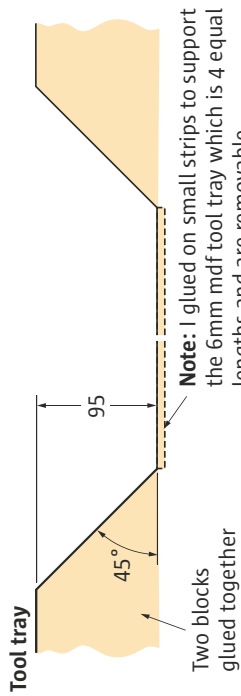

**Note:** I glued on small strips to support the 6mm mdf tool tray which is 4 equal lengths and are removable. The tray also sits on top the cross brace on legs

**Guide for tail vice**

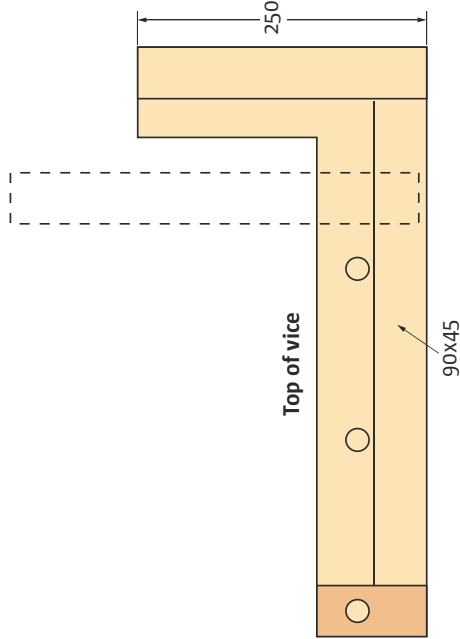
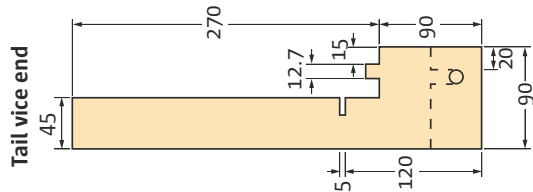
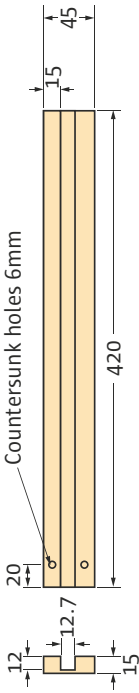

**Dove tails on bench and tail vice**

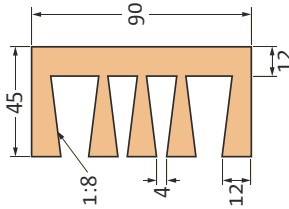

**Legs**

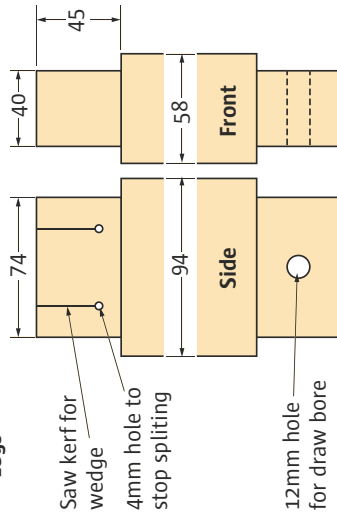

**Note:** Mortise sides 5° for wedges to open tenon

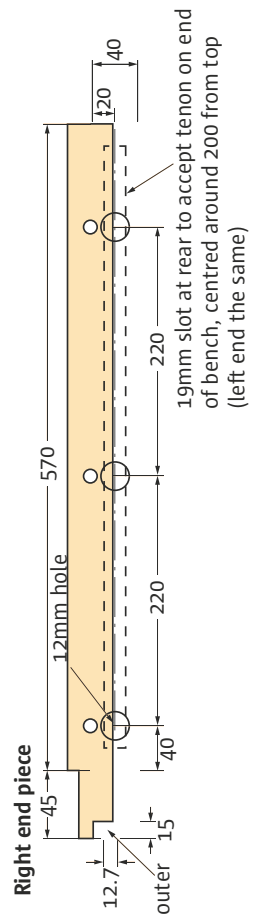

**Note:** Rides in slot in outer piece of tail vice

# John Davis Woodturning Centre

... a working woodturning centre run by Woodturners for Woodturners

not just a shop

*Robert Sorby Day*

**Fri. March 4th 2016**

**10 am to 4 pm**

Come along to the shop and see demonstrations and products from the extensive Sorby range of tools. Talk to the specialists, receive discounts on the day on your Sorby and timber purchases.

**Free parking \* Free entry**



**The Old Stables, Chilbolton Down Farm, Stockbridge, Hampshire SO20 6BU**

email: [admin@johndaviswoodturning.com](mailto:admin@johndaviswoodturning.com)

Shop Open: Mon - Sat 10am - 5pm, Sun 10am - 2pm

[www.johndaviswoodturning.com](http://www.johndaviswoodturning.com)

**Tel: 01264 811070**

## hand tools and wood chisels specialist

Ashley Iles - Henry Taylor - Robert Sorby - Joseph Marples  
Veritas - Clifton - Thomas Flinn - Flexcut - Ice Bear...

*All items in stock, ready for dispatch..*  
\*unless marked otherwise all prices inclusive of VAT



saw horses

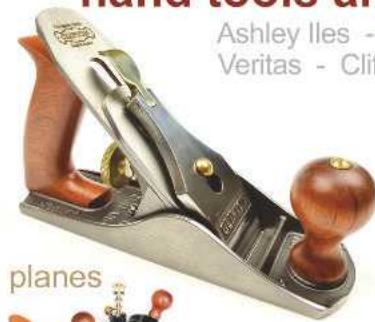

planes



sharpening stones and tools

chisels

drilling

measuring and marking



Order online today at  
**[www.toolnut.co.uk](http://www.toolnut.co.uk)**

or call to order on 01424 224269



tool storage

punches



# In brief...

## FROM FIREWOOD TO SCULPTURE

We couldn't help but feature these stunning sculptures made from discarded wood, which are lovingly crafted by South Korean artist Jae-Hyo Lee. This master of manipulation takes unwanted pieces of wood and turns them into three-dimensional sculptural pieces that are both elegant and functional.

In terms of the process he uses, Jae-Hyo Lee assembles various chunks of wood, then burns them before carefully polishing them to create visual contrast and a smooth surface.

As he explains: "I want to express the wood's natural characteristics without adding my intentions. I like to make the most of the material's inherent feeling. Little things add up to transmit a stronger power, greater energy; that is why I have quite a lot of large pieces."

Having worked with other mediums in the past, Jae-Hyo Lee made the decision to turn his hand to more natural materials and the result is these wonderful sculptures, many of which are now displayed in hotels and other busy locations. The beauty of his work is that unlike pieces in galleries, Jae-Hyo Lee's work is surrounded by people every day.

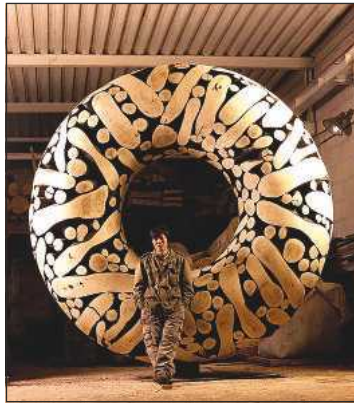

## SOMETHING FOR EVERYONE

This year's 'Midlands Woodworking & Power Tool' show takes place at the Newark Showground, Nottingham from 18–19 March. Now in its third year, this show is one of the most popular events on the woodworking calendar.

There really is something for everyone at the show – turners including Andrew Hall, Mick Hanbury, Jennie Starbuck, Tony Wilson and Simon Hope; carvers including Michael Painter and Emma Cook; furniture making with Peter Sefton and Peter Tree; sharpening with Nic Westermann; Colin Hickman will be demonstrating 'stick making' and Wayne Mack will be demonstrating the scrollsaw.

A visit to the 'Midlands Woodworking & Power Tool' show is probably one of the best days out you could have this year. Advance tickets, which save money and queuing, are now available by either calling the ticket hotline – 01474 536 535 – or visiting the show website: [www.nelton.co.uk](http://www.nelton.co.uk).



## GET INTO GEAR

Brand new from Turners Retreat is this range of Gearshift pen kits, which would make an ideal gift for any car enthusiast. The mechanism design is based on a five-speed 'H' pattern shifter and can be shifted just like the real thing! The cap features a car tyre with a true to life tread and hubcap; the tip features the same tyre tread as the cap. The shifter handle includes an etched five-speed pattern and the industrialised crowbar clip attached to the body with two small screws rounds out the design. Easy to make with a single tube. Refill fully advances at the front of the shifter and fully retracts at the back of the shifter. The pen uses a popular Parker-style refill.

Other kits available include 'Antique Pewter' and 'Antique Brass'. Prices start from £16.99 – see [www.turners-retreat.co.uk](http://www.turners-retreat.co.uk) for more information.



## ARCHITECTURE MEETS NATURE

The Norwegian composer and musician, Håvard Lund has embarked upon an innovative project to create an artist's retreat on Northern Norway's beautiful and dramatic coastline. The retreat is named Fordypningsrommet, the Norwegian word for 'room for deeper studies', as Lund aims at inspiring artists to return to nature and deepen their creative pursuits.

The project consists of six small mono-functional houses with a uniquely playful design and clad in Kebony. The houses include a sauna, sleeping house, kitchen house, studio, the so called "tower for big thoughts", and a bath-house. These dwellings are built on top of angled steel feet and anchored with bolts and concrete to create visually striking angles. Situated in the Arctic Circle, in Fleinvær Archipelago, the buildings have been carefully designed to give stunning views of the distinctive mountains and peaks of the adjacent islands of Lofoten. In summer 2016, the Fordypningsrommet will open to the public.

The serene environment serves as a blank canvas for the creative minds of those who will stay there, providing a quiet retreat from the hustle and bustle of busy urban life. The remote location of Fleinvær means that there are no cars or shops; by stripping away many of the distractions of modern life it is hoped that artists can focus their minds and fully immerse themselves in their projects. The surrounding nature offers unusual high skies and long sights and horizons, which will help artists to work in a focused and effective way. Besides studies, the place will offer concerts, talks, and previews of acts for audiences.

# TOMACO

## THE TOOL MARKETING COMPANY

### DISTRIBUTORS OF QUALITY PRODUCTS



Chisel and plane iron sharpener - take anywhere and sharpen in seconds.

# narex<sup>®</sup>

Quality range of woodworking hand tools made in Europe.

# COLT<sup>®</sup>

PROFESSIONAL TOOLS

A quality range of professional Drill bits and accessories from Germany.

# T TOMAHAWK TOOLS

A quality range of professional tools and accessories.

# VETO PRO PAC<sup>®</sup>

TOOL BAGS THAT WORK

Range of the toughest tool bags with a 5 year downtime warranty.

# CMT ORANGE TOOLS<sup>™</sup>

Quality cutting tool range which includes Router cutters, Spindle Moulding, saw blades, holesaws and many more from Italy.

FOR YOUR NEAREST STOCKIST VISIT

[www.tomaco.co.uk](http://www.tomaco.co.uk)



BY COLIN SIMPSON

# Offset elegance

**Colin Simpson goes back to box making this month and shares an idea for incorporating a graceful curve**

I have shown you how to make boxes before but this one is slightly different as it has an offset lid. Making boxes is a good way of testing your turning skill as they require a little accuracy to make the lid fit well and, because they are small, they can often be made from offcuts of wood, making them very economical. Above all, they are great fun to make.

The offset lid is accentuated by the graceful curve of the whole piece. It would not have looked as good had the sides been straight. I started with a piece of olive ash measuring 125mm long by 85mm square, but you can, of course, make yours any size and from any wood. The main criteria is that the wood must be dry and stable. [www](http://www.getwoodworking.com)



1 Start by mounting the blank between centres and turn to a cylinder using a spindle roughing gouge



2 Square off and cut a spigot to fit your chuck on both ends of the blank



3 Mount the blank in your chuck and turn the cylinder to a flowing curve or cove

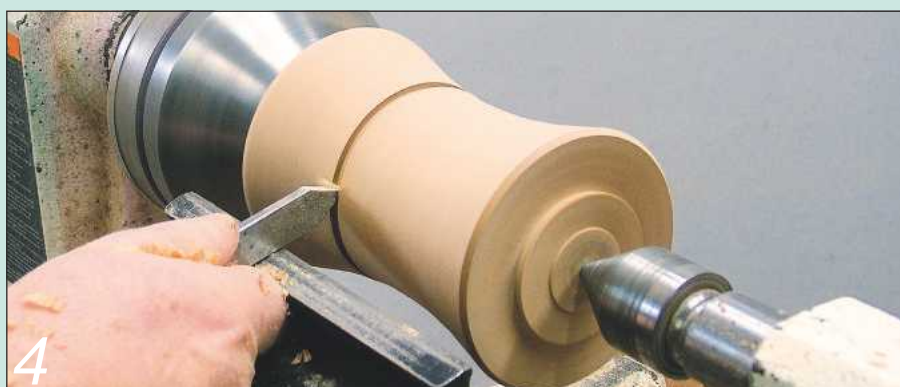

4 Measure approximately 40mm in from the headstock end and cut an 8mm wide groove about 8mm deep, using a parting tool



5 Before parting off, completely mark a witness line on both sides of the groove; this will help line up the grain



6 Use a narrow parting tool to part the blank into two. This will leave a tenon to the right of the cut; this will become the lip of the base



7 If you don't like the idea of parting through completely, then stop the lathe and cut the lid from the base with a saw. The piece that is left in the chuck will be the lid



8 Measure the diameter of the tenon on the base using Vernier callipers...

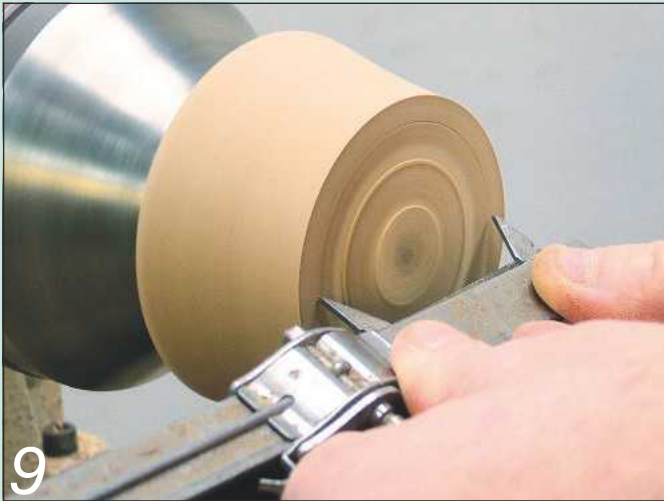

... and transfer this measurement to the lid



Use a spindle gouge to hollow the lid to about 20mm, leaving the lid quite thick. If you wish, turn a couple of decorative beads on the inside of the lid



Use a skew chisel on its side to cut a straight-sided recess on the marked line. This should be about 6mm deep



It is important that the side of this recess is parallel. Check it with inside callipers and correct if necessary



Sand and polish the inside of the lid, being careful not to damage the parallel-sided recess



Remove the lid and mount the base. Drill a hole down the centre of the base using a spindle gouge



The hole can now be widened using the 10mm spindle gouge. Start the cut with the tool in the hole and the flute pointing towards 10 o'clock, then swing the handle away from you. Continue to hollow the box in this manner until you reach the bottom of the drilled hole



When you've hollowed as much as you can with the spindle gouge, use a skew to cut down the side wall and then across the bottom of the box



17 Sand the inside. When sanding the inside of a hollow, use only one finger like this and do not wrap the abrasive around the finger. Polish the inside



18 Use a skew chisel to cut a small chamfer on the tenon...



19 ... and offer up the lid. The lid should fit somewhere on the chamfer and if the lathe is running as you do this...



20 ... then the lid should leave a light burnish mark



21 Reduce the size of the tenon to this burnish mark and, in theory, the lid should be a good fit. Aim for a tight fit at this stage – it can be eased later



22 Fit the lid and re-shape the outside cove, blending the lid to the base



23 My lid was a good, tight fit but it is vital that the lid does not move during the next process. Use masking tape here to help keep it in place



24 Mount the lid and base between centres, again with the lid at the tailstock end. Offset the centre of the lid by about 20mm



25 I used a Robert Sorby Steb centre in the headstock, but because only a few teeth are biting into the wood, use hot-melt glue to help secure it



Use a spindle gouge to turn the top of the lid to a dome shape. Because it's spinning off its true centre, this is a difficult cut as you are initially cutting more air than wood. Take light, gentle cuts here



Aim for something like this, leaving a small stub at the revolving centre, which can be sanded off by hand. Aim to blend this into the curve of the lid



Mount the box on the spigot at the base to give it a final sand and polish



Remove the lid and reverse chuck the base onto a small dolly. Bring the tailstock up to hold it in place and turn away the spigot on the bottom of the base. Aim to slightly concave the base, leaving a small stub for the revolving centre. Remove this by hand, off the lathe



**30**

Finally, I like to buff small pieces like this using my Beall buffing system



So what do you think of the finished box?



DIGITAL  
SUBSCRIPTIONS  
AVAILABLE ONLINE!

# Receive a **FREE** Set of Pica Marker Products\* when you subscribe today

**WORTH £20**

**“Very handy and  
convenient for  
any woodworker**

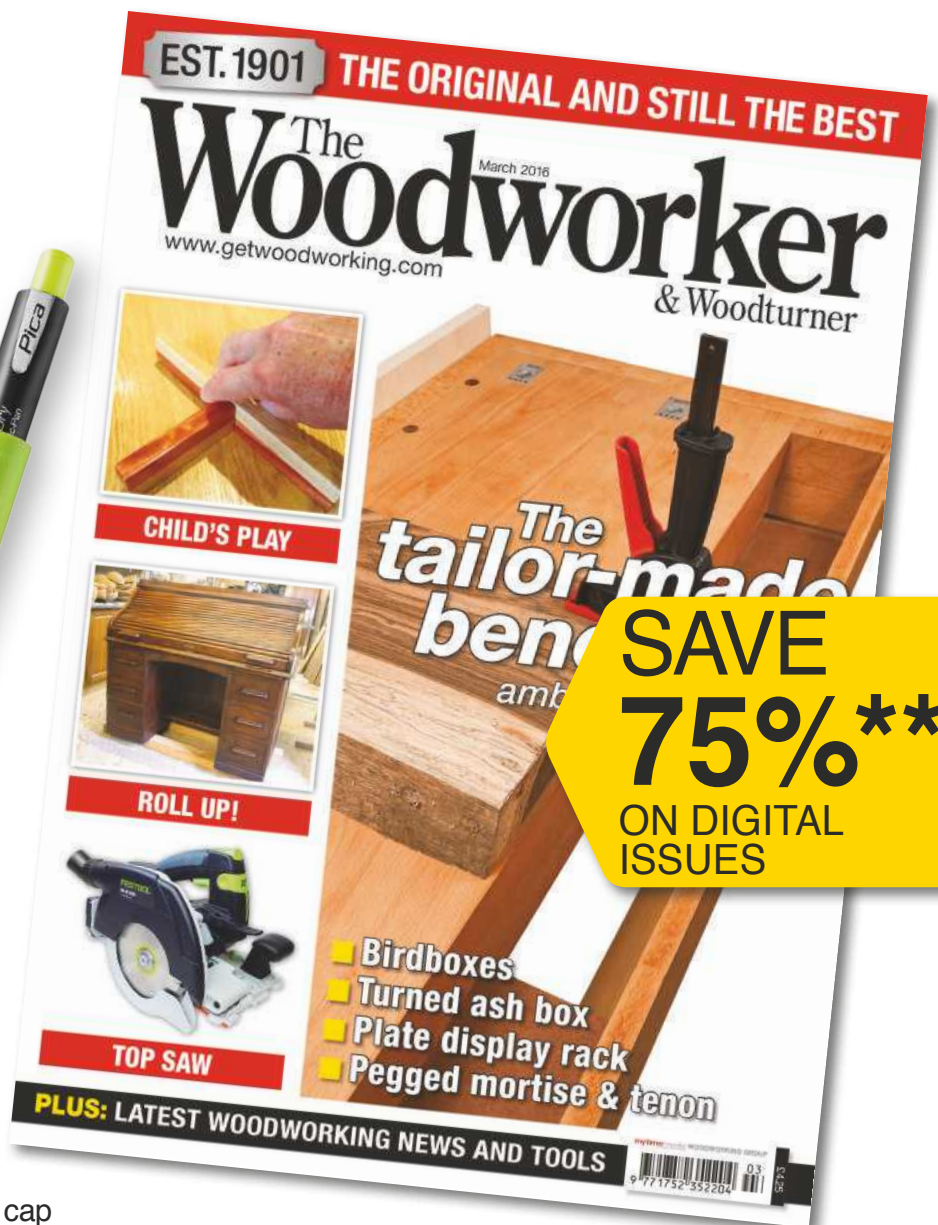

The **Pica-Dry** marks and writes on all material surfaces – even on dusty, raw, oily, wet and dark surfaces. It features an automatic lead support, a stainless steel tube, a built-in sharpener on the front of the cap as well as a convenient quiver cap with special clip

The **Pica POCKET** features a belt or pocket-mounted protective scabbard and can either hold the Classic 540 pencil or the Classic 541 version, which features an ultra-hard 10H lead. A stainless steel blade is also built in for sharpening the pencil.

TERMS & CONDITIONS: Offer ends 11th March 2016. \*FREE Gift for UK subscribers only, while stocks last. \*\* This digital discount is only available when you subscribe to the 'Print + Digital' package. You can still get a great discount on the digital package, please visit the URL stated below for more information. Please see [www.mytimemedia.co.uk/terms](http://www.mytimemedia.co.uk/terms) for full terms & conditions.

# NOW AVAILABLE IN THE UK **EXCLUSIVELY** FROM THE TURNER'S WORKSHOP

\*Wholesale Inquiries Welcome



[www.theturnersworkshop.co.uk](http://www.theturnersworkshop.co.uk)  
[mail@theturnersworkshop.co.uk](mailto:mail@theturnersworkshop.co.uk)



Fast-Drying • Chemical & Impact Resistant • Easy To Apply • Low Odor  
Non-Flammable • Water Cleanup • Can Be Applied While Turning • Low VOC

Welcome to  
**THE TURNERS  
WORKSHOP**  
*The Company  
with Traditional Values*

Our aim is to provide  
quality items at a fair price.

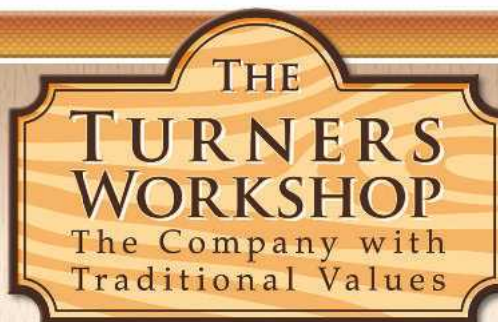

*In the hussle-bussle  
and impersonal world we  
live in today, I want to turn  
back the clock and provide  
a good old fashioned,  
personal, professional and  
friendly service to all my  
customers.*

*Vincent Coates - proprietor*

- Pen Kits
- Woodturning Tools
- Abrasives • Adhesives
- Bushing Sets
- Finishing Products
- Books & DVDs
- Pen Making Accessories
- Workshop Furniture
- Knife Making Sets
- Turning Projects



*The Turners Workshop will appeal to all Woodturners, Pen Makers,  
Pen Collectors, Craftsmen and Craft-ladies! Visit our comprehensive shop at:*

[www.theturnersworkshop.co.uk](http://www.theturnersworkshop.co.uk) • Tel: 07870 587615 • email: [mail@theturnersworkshop.co.uk](mailto:mail@theturnersworkshop.co.uk)

WAREHOUSE/VISITING - UNIT 13, MORGAN BUSINESS PARK, MYLORD CRES,  
CAMPERDOWN IND. EST, NEWCASTLE UPON TYNE, NE12 5UJ



Visitors by prior appointment to our warehouse

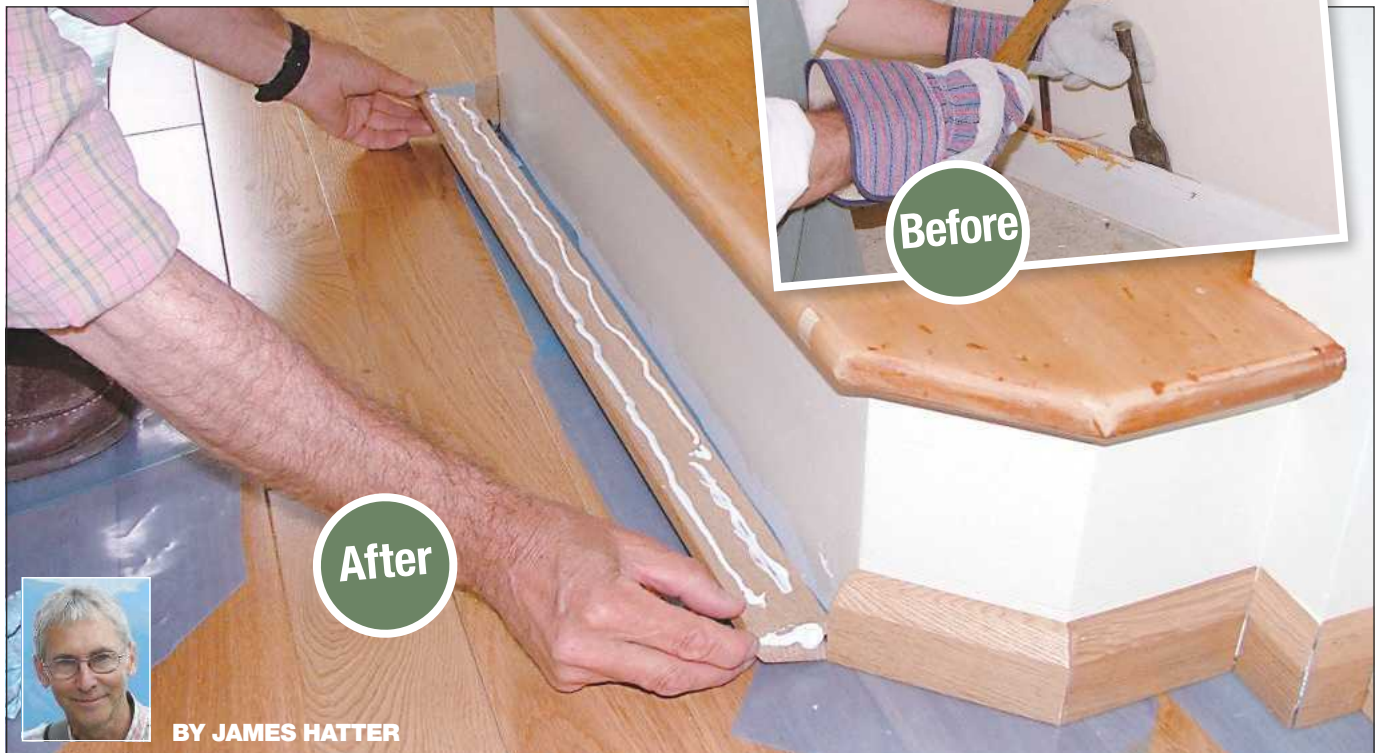

BY JAMES HATTER

# Skirting round the details

Even simple skirting can provide a decorative feature, as James Hatter shows you here

## Tools you'll need

Measuring tape, square, table saw or circular saw, mitre saw, router (preferably table-mounted), router cutters, sealant gun, hammer, bolster chisel and safety gear

**A**s I'm sure you're well aware, the bottom edge of the wall that meets the floor is traditionally finished using some form of skirting. This provides both protection for the plastered wall and a decorative feature. If you need to fit or replace skirting you could choose from a wide range of mouldings made from solid timber and MDF, but why not make your own?

MDF is a useful material for skirting because it can be cut and shaped easily, is free of the usual surface imperfections of real timber, and is relatively stable. It does need to be sealed well, though, and may not be suitable for moisture-prone areas, although moisture-resistant grades are available.

Simple but effective skirting can be made by cutting a sheet of 12mm-thick MDF into

70mm-wide strips moulding the top outer edge with a 6mm round-over cutter and a router. More elaborate designs can be produced depending upon your range of tools. With more tools and a little imagination, however, you can come up with other, more elaborate designs. One type I have made consists of 145mm-wide strips of 18mm-thick MDF. I cut a decorative moulding along the top edge using an ogee cutter and a V-cutter in a table-mounted router. By taking account of the positions of the door surrounds, I was able to stop the decorative moulding short of the door architrave; cutting away the bottom 145mm of the architrave then allowed me to let the new skirting boards into the door surround. The same principle could be used with solid

decorative timbers such as ash or oak.

If you are replacing existing skirting boards, then you can remove the old skirting with a bolster chisel and hammer. It is likely that some of the nails (often cut-clasp types) holding the original skirting will remain after you've pulled it away. To remove them, strike the head of the nail with a hammer to bend it, then use the claw to lever it out; stubborn nails can be broken off flush with the wall by knocking the nail from side to side until it snaps.

Make a sketch of the floor plan and measure the lengths of skirting required. Cut the pieces to length. Long runs of skirting can be made by joining shorter lengths together using jointing biscuits and adhesive, while the corners should be joined with mitres. Inside skirting corner



You can cut MDF into strips to use for skirting easily and efficiently with a table saw

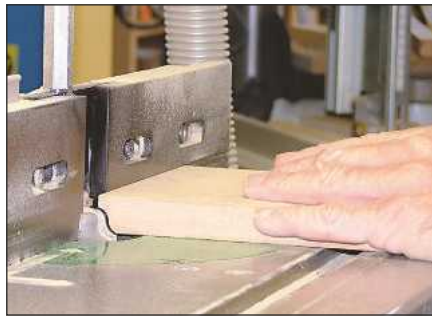

A table-mounted router is ideal for moulding the top edge simple skirting



This moulding was stopped short so that it could be run underneath a door architrave



Use a bolster chisel and hammer to prise old skirting, floor coverings and gripper rods



Trim to exact sizes as required



Fitting the skirting below a vertical architrave...



When all the lengths are cut to size, apply primer, undercoat and the required finish



...is a tidy solution



Apply gap-filling adhesive to the rear of each length of skirting in turn and press them into position

joints are often scribed to overcome the problem of the joint opening up with temperature and humidity changes. This is less of a problem if you're using MDF, of course, so straightforward mitre joints can be used. A powered mitre saw will give quick and accurate results.

After sanding any cut edges, it's best to prime and paint all the skirting boards prior to fixing them. Apply an MDF sealer first, followed by two coats of quick-drying primer/undercoat, and a quick-drying topcoat. These can be applied with a synthetic bristle paintbrush or a small flock roller. More decorative timbers could receive three coats of a clear quick-drying varnish. It's a good idea to use a top coat of clear varnish to help protect painted skirting in vulnerable areas, too.

A convenient and effective way of attaching skirting boards is to use a strong gap-filling adhesive – I prefer the solvent-free version. Apply a continuous bead of adhesive about 10mm from the top inside edge of the skirting and another about 30mm up from the bottom edge. Put a further bead between the two and on the joint with the next board, then press the board into place and wipe away any extra adhesive. If the walls are at all bowed, then you may need to apply pressure to the skirting so that it conforms to the shape. If you are replacing the skirting after laying a new floor, then protect the flooring with a polythene sheet to avoid marking it and to prevent the gap-filling adhesive sticking the bottom of the skirting to the flooring; this is especially important with floating floor coverings. After the adhesive has cured, use a polymer sealant to fill in any minor visible gaps. [www](http://www.getwoodworking.com)

## FURTHER INFORMATION

### Materials

- A standard 1,220 × 2,440mm sheet of 12mm MDF will produce about 38m of 12 × 70mm skirting in 2,440mm lengths at a cost of approximately 32p per metre

### Suppliers

- Wickes Building Supplies
- 0800 106 068
- [www.wickes.co.uk](http://www.wickes.co.uk)
- Screwfix Direct
- 0500 414 141
- [www.screwfix.com](http://www.screwfix.com)
- Crown Decorating Products
- 08702 401 127
- [www.crownpaints.co.uk](http://www.crownpaints.co.uk)
- Ronseal
- [www.ronseal.co.uk](http://www.ronseal.co.uk)



Continue working around the walls, remembering that...



...you may need to bend the skirting to shape if the wall is uneven



Clamps and a piece of timber can be used to hold the skirting in place



For long runs, join the skirting with biscuits and adhesive



Apply a polymer sealant to make an effective and neat seal



See! Even simple skirting can provide a decorative feature

# In brief...

## 3D TALES IN WOOD

Inspired by the relics of his parents' past as Czech publishers and book smugglers, Martin Tomsky produces laser-cut illustrations that introduce depth with several layers of plywood in varying tones. Originally immersed in drawing detailed scenes on paper, Tomsky transferred his skills to the 3D, creating stories that seem tangled in lore and feature the outlines of animal skeletons, dense forestry, and mythical beasts.

The London-based artist aims to create work that speaks to craft, illustration, and sculpture, each piece serving as both a decorative object and wall-mounted story. Although many of his works are large and intricate productions, he also works small, singling out animal characters such as owls, rabbits and badgers in necklace pendants and brooches. You can see more of Tomsky's laser-cut tales on his Etsy page:

[www.etsy.com/TomskyStore](http://www.etsy.com/TomskyStore).



## COMBINED IS BEST

The 10.5mm Star-M HSS screw drill and plug cutter set combines a taper drill, countersink and counterbore to create the perfect starter hole for screws in a single pass. You can alter the shank length with the included Allen key and then simply drill to the appropriate depth depending on whether you want the screw proud, flush, or sunk below the surface.

The matched plug cutter produces an accurate, concentric plug that fits the counterbored hole perfectly.

There are cheap versions of this type of tool on the market, but Workshop Heaven has gone for the top spec Japanese high-speed steel option. This gives maximum service life and no problems if you work with hard exotics or occasionally need to countersink through an applied brass plate, for example.

Sold as a set priced at £31, 10mm plug cutters are available. See [www.workshopheaven.com](http://www.workshopheaven.com).

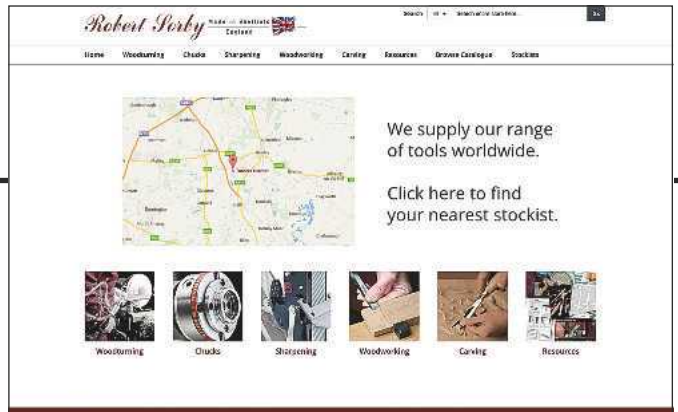

## SHEFFIELD'S BEST LAUNCHES NEW WEBSITE

Woodworkers have a new and exciting resource at their disposal after Robert Sorby announced the launch of its new website. The website has been built using the latest in responsive design making it easy to use on all computer devices and Smart phones.

As well as in-depth product information on a huge array of Robert Sorby woodworking tools and accessories, the new site offers the opportunity to download product instructions, view engaging and informative films, win fantastic prizes and gives users the chance to provide advice and opinion on its online forum.

The site also boasts an interactive flip-through digital catalogue, allowing browsers to click-through from links in the catalogue pages to website pages, where further information and engaging content is available at the click of a mouse.

Woodworkers wanting to locate a stockist can easily find directions through Google Maps and a handy link under each stockist's contact details takes the browser straight to their preferred stockist's Robert Sorby pages.

Visit the 'Resources' menu for a range of additional exciting features including the 'Tools' and 'Techniques' pages where some of the world's best known woodturners let you into their secrets.

Future plans include having an online review section where users can rate tools and a Robert Sorby tools users' gallery where woodworkers will be invited to send in photos of their work and what tools they used to complete it.

To see it for yourselves, visit [www.robert-sorby.co.uk](http://www.robert-sorby.co.uk).

## HAIL THAT CAB!

Makita has teamed up with specialist decorators merchant, Leyland SDM, to showcase the brand partnership and two London cabs are now in circulation carrying the joint branding. The famous London black cabs are often far from black, being covered in attractive advertising graphics for brands and businesses that value the moving billboard opportunities to reach people in London any time of the day or night.

Leyland SDM has 17 branches across London, see [www.leylandsgm.co.uk](http://www.leylandsgm.co.uk), and to find out more about Makita products, visit [www.makita.com](http://www.makita.com).



# Thomas Flinn & Co.

Saw & Hand Tool Manufacturer  
Sheffield, England



The UK's last remaining traditional saw manufacturers.  
**Now also manufacturing Clifton Planes  
including a NEW Block Plane!**

*Garlick*  
MADE IN SHEFFIELD  
ESTABLISHED 1858

**E.T. ROBERTS  
& LEE**

**PAX**  
ESTABLISHED 1776

**CLIFTON**

[www.flinn-garlick-saws.co.uk](http://www.flinn-garlick-saws.co.uk)  
[orderonline@flinn-garlick-saws.co.uk](mailto:orderonline@flinn-garlick-saws.co.uk)  
Tel: 0114 2725387



[www.routercutter.co.uk](http://www.routercutter.co.uk)

your online mechanism for resourcing quality tooling  
specializing in 'industrial grade savvy'

**Contact**

Website: <https://routercutter.co.uk>

Email: [sales@routercutter.co.uk](mailto:sales@routercutter.co.uk)

Office address: ROUTERCUTTER.CO.UK

South Point / Old Brighton Road

Lowfield Heath / Crawley

West Sussex / RH11 0PR / UK

Our online stocks are genuine and all goods are mailed from the UK.

**Whiteside** have been manufacturing quality industrial grade router bits for more than 30 years. Proudly made in North Carolina USA. Router bits designed & engineered for the Woodworker.

We now also stock **Southeast Tool Inc.** router bits and accessories. Tools from the smiley people. Made in USA.



**IN STOCK NOW:**

**The "ULTIMATE"**

**PATTERN & FLUSH TRIM BITS**

**2+2 Compression Technology**

Bearing guided for every workshop

UDP9112 Pattern Bit

UDFT9112 Flush Trim Bit

UDC9112 Combination Bit

by **WHITESIDE**

**ALSO NOW IN STOCK:**

**2 flute spiral bits with metric "D"**

1/4" shank, 5mm cutting diameter

1/4" shank, 6mm cutting diameter

1/2" shank, 8mm cutting diameter

1/2" shank, 10mm cutting diameter

1/2" shank, 12mm cutting diameter

Custom made in the USA by **WHITESIDE**

Special price on **WHITESIDE RD5200A**

1/2" shank, down cut spiral

D = 12mm; c/l = 50.8mm; o/a = 101.6mm

**GBP 35.00 per piece**



**WHITESIDE MACHINE COMPANY**

Nominated in both categories by Fine Woodworking Magazine June 2007 - in an 18 bit road-test evaluation

Author's Choice - BEST OVERALL / Author's Choice - BEST VALUE

# Flexidisc Sander/Grinder

The Flexidisc sander gives a superb finish on wood, metal, fibreglass, car body filler and all hard materials.

Its fast rotation speed achieves sensational results in a fraction of the time normally taken by conventional sanders.

This versatile tool also sharpens chisels, plane blades, lathe tools, axes and garden tools without the rapid overheating of normal abrasive wheels.

This is the ideal tool to prepare your timber prior to varnishing with Le Tonkinois varnish.

[www.flexidiscsander.co.uk](http://www.flexidiscsander.co.uk)

Tel: 01628 548840



# Le Tonkinois Varnish

Le Tonkinois is a natural oil based yacht varnish.

Perfect for outdoor, indoor and marine use. With Le Tonkinois varnish the options really are endless.

Combining unrivalled protection on materials including cork flooring, stone, metal and wood and brilliant permanent penetration, Le Tonkinois varnish leaves absolutely no brush marks and will restore the natural beauty of timber whilst removing your brush marks.

Flexible enough to move with the timber and able to withstand abrasion and impact, Le Tonkinois varnish is resistant to boiling water, UV, petrol, diesel and sea water. It won't crack, chip or peel off, making it perfect for all outside purposes as well as indoor.



[www.letonkinoisvarnish.co.uk](http://www.letonkinoisvarnish.co.uk)

Tel: 01628 548840

Unguided edge tool: from wasting to delicate shaping, the drawknife can be made a jack of many trades



# Weapon of choice

**Mike Riley's quick on the drawknife's benefits, but there's a shock horror concession, too**

**T**here must have been a time when every woodworker had a drawknife in his toolbox. It's the only way to account for the vast number available today in secondhand tool shops and on eBay; my friend even found one buried in a field recently, and after being cleaned up, he was able to press it back into service. If you don't want to go metal detecting, though, and don't want to buy a secondhand drawknife, Classic Hand Tools or Raylles will sell you a new one, or you could even make your own – old and worn-out files are perfect blade donors.

But there I go again, getting ahead of myself. What is a drawknife, you're wondering, and what's it for? If you've never come across this tool, it's really nothing more than a large blade with two handles,

though there are variations in the design to suit different applications. While it's a simple tool, the drawknife has a large range of uses, from stripping the bark off rough timber, to putting decorative chamfers on the finest furniture. These days, it's most commonly used for rounding turning blanks, though many turners now use a bandsaw for this purpose. You're also likely to see the drawknife in the hands of a traditional green woodworker, or a stick chairmaker. The latter will use it for making the legs, rungs and back posts, and then possibly take up another form of drawknife – the scorp – with which to saddle the seat.

## Tea, talk, tasks

It was the lack of a bandsaw in my workshop, as well as a chat with Bruce



The shavehorse is a good aid when using the drawknife...

Photograph by Paul Felix



...as demonstrated here by Don Williams

Photograph by Paul Felix



The tool can be used to remove timber quickly or make the lightest cuts

Manning, that started me thinking about using a drawknife. Not having a bandsaw limits my ability to cut straight lines, and anything requiring curves has meant breaking out my fretsaw, which I've never managed to master and which seems more inclined to create a pile of snapped blades than curved profiles. A drawknife, on the other hand, can take the heaviest of cuts, wasting away wood quickly to get down to a scribed, curved line.

It was for this reason, then, that I thought I might be able to get by with a drawknife instead of a bandsaw for some tasks. However, after a good deal of practice, I discovered that a drawknife can also take the lightest cuts to chamfer edges or to create delicate curves and rounded sections. From being a replacement for a bandsaw, the drawknife has become my tool of choice for many shaping tasks, even to the exclusion of the spokeshave.

### Pros and cons

Now, brace yourself for a rare admission.

I can't help thinking that although the drawknife can waste wood away from a blank as fast as a bandsaw, if not faster, the result is a pile of waste material, rather than offcuts, which may have had a use other than in the fireplace. In an age of limited and expensive materials, this highly wasteful and probably inappropriate use of resources could be avoided by using a bandsaw. There, I've said it! I've justified powered machinery in the hobbyist's workshop.

The thing that causes me the biggest problem when using a drawknife is also its biggest strength. Although essentially an unguided edge tool like a chisel, I think

it's closer to the plane family of tools, as the blade is drawn along the work to slice it, rather than directed at paring specific areas as you would with a chisel. But of course, it lacks a sole, which means that while it's capable of extremely fine work – the shorter the sole of the plane, the more focused its application can be – you have to be careful that the blade doesn't dive into the wood and rip out large chunks along the grain.



This is very easy to do, ruining hours of work with a moment's inattention: the workmanship of risk again. For this reason I tend to start with bigger stock than I would otherwise use so as to allow myself a chance to rectify mistakes. Of course, this is a flawed kind of logic, as I still have to get to my target dimensions, and the risk of ruination along the way exists until the moment I stop cutting. And if anything, starting with stock that is too oversized is just as wasteful.

With any tool work, good workholding is essential, but in this case it isn't just a matter of keeping the work from moving. Usually, I clamp my work either in my bench end vice or in an old Record vice on the bench top, depending on how big it is. When using a drawknife, however, you need the work to be easily movable so that you can reposition the piece frequently and accurately. You also need to be able to reapply secure clamping after each movement. If you can't, not only does this make working with the drawknife unnecessarily fiddly and time-consuming, but I think it tends to encourage you to work too long in the same spot and so lose track of the overall target shape. I'm always aware that I spend too long or focus too closely on smoothing out the facets that the tool creates rather than roughing out a shape first and then returning to the finish work at the end, which is how it should be done. This often leads to an imbalance in shaping that it's not always possible to rectify without starting all over again.

### Bring on the shavehorse

The shavehorse is designed specifically for this problem. It consists of a three-legged bench on which the user sits with a clamping arrangement; this is locked and released by foot power, holding the work stationary for shaving but also allowing for quick-release and repositioning. One of the main benefits of the shavehorse is its portability, as it can be set up wherever you need it. This might mean, as it once did, that it's carried into woodland to the material, or simply into the back garden in summer months. My experience thus far with the drawknife tells me that a shavehorse is essential, and I will be building one.

The alternative is something known as a shaving pony, which is essentially the same quick-release clamping device, but held in the bench vice. One downside is that the operator must work standing on one foot, as the other foot is used to operate the clamp. This is not only tiring, but also potentially dangerous to both woodworker and work, and it means that you're anchored to the bench rather than positioned comfortably.

### Breast bibs?

Another means of holding work when using the drawknife is one which I have also used with smaller pieces: the breast bib. This is just a squarish scrap of wood – I used 10mm plywood for mine, with two small holes drilled in adjacent corners, through



In appearance, the drawknife is essentially a chisel with two handles; it's perhaps better likened to a plane without a sole

which a length of twine is threaded. The breast bib hangs around the neck and sits on the chest like a baby's bib, not only keeping your lunch off your workshop apron or shirt, but also giving you a thick, solid surface to pinch the workpiece against without impaling yourself on the end of the wood. It can also act as a kind of woodworking Kevlar in the eventuality that you get carried away with the drawknife; but you'd have to be extremely clumsy to draw the blade into your body, as it requires that your shoulders, elbows and wrists are all behind your point of contact. I personally find that quite an effort to do on purpose, let alone by accident, although it's possible that my difficulty is just a sign of incipient old age.

### Practice makes projects

I can see that it's possible to achieve great things and fine work with a drawknife, although it's definitely a tool which requires, and rewards, practice; it won't give instantly

useful results. This is perhaps one reason why they were once so prevalent in the toolbox, but less so now. Once I've fully got to grips with the tool, however, there is a long list of projects where I can see it being useful. Most of these call for a shaping tool, which is where I think the drawknife can excel, at least in hands more skilled than my own.

While I still think that a drawknife can be used instead of a bandsaw for rough ripping and shaping of stock, I do think this is a wasteful and avoidable process. Therefore, I have to admit that there is a plausible case for machinery here. In fact, I can see that a bandsaw might have a useful and economical application for the workshop of the small-scale professional or hobbyist. [www](http://www.classichandtools.com)

### FURTHER INFORMATION

■ To buy a drawknife of your own, visit [www.classichandtools.com](http://www.classichandtools.com), or [www.oldtools.free-online.co.uk](http://www.oldtools.free-online.co.uk)



The drawknife is now my shaping tool of choice. It's what enabled me to create my elegant wooden spoons

THE UK'S PREMIER BRANDED HAND, POWER TOOLS & MACHINERY EVENT



# 'THE' TOOL SHOW '16

WWW.THETOOLSHOW.COM

FREE ENTRY • FREE PARKING • FREE SHOW GUIDE • FREE MASTERCLASSES  
LATEST PRODUCTS • EXCLUSIVE SHOW OFFERS • DEMONSTRATIONS • BIG SAVINGS



**FREE ENTRY & PARKING!**

**PUT THE DATE IN YOUR DIARY!**

**VISIT STANDS STAFFED BY THE MAJOR BRANDS INCLUDING:**



**THIS YEAR'S BIGGEST & BEST ANNUAL TOOL SHOW**

# 7th-9th OCTOBER 2016

**FRI-SAT 10am – 5pm • SUN 10am – 4pm**

**KEMPTON PARK RACECOURSE • SUNBURY-ON-THAMES • TW16 5AQ**

**D&M TOOLS, TWICKENHAM • 020 8892 3813 • WWW.DM-TOOLS.CO.UK**

# Great Big Scroll Saw<sup>®</sup>

*Ideal for internal cuts in thick timber*



**As seen on  
YouTube**

**CUTS 3" AND THICKER TIMBER**

**QUIETER • SAFER**

**NO ELECTRICITY REQUIRED • LESS INTIMIDATING**

**VERY CONTROLLABLE • GOOD EXERCISE**

*For parts and instructions visit our website*  
***[www.greatbigscrollsaw.com](http://www.greatbigscrollsaw.com)***

*Solid, comfortable and with a low centre of gravity, the Festool HK 55 EQ is a pleasure to use*

# Festool HK 55 EQ saw with FSK 420 rail

This truly is a golden era for power tools; never have they performed so well nor suited user requirements so completely. The new rail saw from renowned German specialists Festool is a case in point. Designed purely with the on-site carpenter in mind, the combination of a robust and reliable plunge saw with the versatile accuracy of a lightweight rail is an irresistible solution. Proving the worth of lengthy research, stringent quality control and a loyal workforce, Festool have upped the stakes again in the worldwide quest for improved performance and constant precision. That's not to say it's perfect, mind, but this particular sawing system is definitely heading in the right direction.

## Solid and comfortable

It's a solid and comfortable fit in the hand and, although designed primarily for right-handers, it's not as cumbersome to use for lefties as some power tools can be. If anything, the improved view of the blade could be considered an advantage by some of this particular minority. It shares most of the features common to a hand-held circular saw, and there's nothing to stop you using it freehand if you so wish; it functions just as well as a regular circ. Sharing a feature with a few other design-conscious manufacturers in the market, the user interactive elements of the tool are cast in the company's trade mark lime green colour (RAL 6018), and clearly identify all of the controls and adjusters.

## Plunge facility

There's a standard soft grip handle from which the thumb slide can be reached and enables the trigger to be pulled. This activates a short slow start for the motor, the running speed of which can be readily set prior to operations courtesy of a rolling switch nearby. Speeds vary from very slow indeed to the familiar brisk rate to be found on most other similar machines. It's a comfortable saw to use, especially with the forward mounted handle or tote, and its weight and balance inspire confidence right from the start. This model is the 55, this being the maximum depth of cut from the blade (without the rail). The cutting depth can be set from the start

by means of a sprung lever, a clear scale, and a positive adjustment action. The saw also has a plunge facility, useful for piercing cuts as might be found on a kitchen worktop, for example. The saw is first set to depth then, on releasing the plunge lever, the body of the saw lifts off from the base from whence it can be readily plunged into the workpiece.

## The rail

The rail, available in three different lengths, features a sliding stop on one side, which enables the user to make a variety of angled cuts (on either hand) and sets the whole system up as a serious rival to a portable chop saw. Common to this type of saw, there's a plastic strip at the cutting edge of the rail which is lightly trimmed on setting up for the first time; from then on the blade will give the cleanest of cuts and with no break out on cross-grain work.

Blade guards on hand-held circular saws can often prove troublesome, frequently getting snagged on even the smallest of obstructions. You definitely don't want to be employing excessive force when using a power saw (and don't even think about taking the blade guard or riving knife off!) so it's always necessary to stop and attend to the problem. Most saws only have a tab on the actual guard itself, but the Festool saw boasts a geared lever, which flips the guard out of the way from the safety and comfort of the handle. Top stuff.

## Saw and rail connection

One feature I wasn't sure of at first is the way the saw and rail stay connected throughout; after each cut the rail springs softly back



The Festool HK 55 features a solid and comfortable build format with a low centre of gravity

Depth adjustment is precise and with an easy-to-read scale



This lever controls the blade guard and will flip it back with ease





**£387**

### SPECIFICATION

POWER	1,200W
IDLE SPEED	2,000-5,200rpm
BLADE DIAMETER	160mm
ANGULAR RANGE	0-50°
CUTTING DEPTH	0°/90°-0-55mm
WEIGHT	4.4kg

### VERDICT

Although a pricey setup, this is a fantastic cutting system which is built to last

- PROS**
- Accurate
  - Efficient
  - Versatile

- CONS**
- The plastic edge strip on the rail could be better adhered

**VALUE FOR MONEY PERFORMANCE**

### FURTHER INFORMATION

- Festool Tools
- [www.festool.co.uk](http://www.festool.co.uk)

into place in readiness for the next job. This conjoining soon grew on me throughout the day on site, however, and I realised it was actually a boon for awkward repeat cuts or when you can't spare another hand.

#### In summary

A terrific cutting system; after the initial shock of parting with the money wears off you'll never regret buying one. *MC*



On site the saw really proved its worth, and was judged indispensable. It saved me having to drag my chop saw along too



The hex key for changing the fine-kerfed blade is tucked away in the handle



The guiderrail, showing the plastic edge strip – a darker colour would have shown up better



Speed control. At its fastest, it remains un-scary

Robust in use with rugged comfort, this combi drill driver from Triton also benefits from a long runtime

# Triton T20 combi hammer drill

## 20V 4.0AH T20CH



There's always something special about a new drill. It's the first power tool on the list for anyone starting out, or if you just need to do a few jobs around the house.

The Triton combination drill featured here is a good example of keeping it simple and doing things well.

### In use

Some 18V power tools are badged as 20V these days; it's mostly a marketing device which, although technically accurate, is slightly confusing for the buyer. Not to worry, though – of greater significance on this one are the 4Ah batteries, which denote a longer potential runtime than most others. I have to confess to paying little heed to these numbers, however, and judge each tool on its performance alone.

Certainly the Triton did all I asked of it when tasked with a number of IKEA-related home improvements. Regular brick and block posed little in the way of obstructions (a fresh masonry bit makes all the

difference), but I found it a struggle to make much headway in engineering brick and cast concrete. You really need an SDS for this sort of work, but for anything else, a drill like the Triton T20 should be ample.

The T20 handled nicely, a combination of size, weight and soft grip all meant for a comfortable user experience, but I felt the controls could have been easier to operate – the selector rings and chuck all worked better with a pair of work gloves on.

The batteries charged up fairly quickly, but I found the system of light indicators a bit confusing. Flashing red light? You'd think trouble wouldn't you? Yes, but not really; the instruction table lists a variety of possible causes and in the end I just ignored everything until I saw a steady green lamp, the signal for 'fully charged and good to go' – just one more supporting reason for product standardisation.

### In summary

All things considered, this is a good, robust, workaday drill driver. **MC**

### SPECIFICATION

<b>PRODUCT WEIGHT</b>	1.9kg
<b>VOLTAGE</b>	20V
<b>SPEED</b>	0-450, 600rpm
<b>BATTERIES</b>	2
<b>BATTERY TYPE</b>	4Ah Li-ion Samsung (SDI INR18650-20R cell)
<b>BELT CLIP</b>	Yes
<b>CHUCK TYPE</b>	Keyless
<b>CAPACITY</b>	1.5-13mm
<b>VARIABLE SPEED</b>	Yes
<b>MAX TORQUE</b>	60Nm

### VERDICT

**PROS** ■ Rugged comfort  
■ Long runtime

**CONS** ■ Chuck could be easier to tighten

**VALUE FOR MONEY** ■■■■■■  
**PERFORMANCE** ■■■■■■

### FURTHER INFORMATION

■ Triton Tools  
■ [www.tritontools.com](http://www.tritontools.com)



A 4Ah battery on charge showing green for 'go'



The well-placed work lamp – a bright LED



The two selector rings: one on 'drill', the other on 'max torque'



The complete kit, with capacious tool bag

Smart is making big inroads into the market of compatible blades for multi-tools

# Smart SMTX Multi-Fit blades

From  
£7



The SMTX Multi-Fit design covers all the major manufacturers' retention systems for a 'one blade fits all' option, giving you an alternative to own-brand designs that can be limited and expensive.

Smart also offers alternative profiles to the SMTX if you do own a more obscure or older machine as well as the newer DeWalt design with the clipped rear opening slide-on style. This DeWalt style uses the same SMTX profile to cover the majority of models, but my test blades were the fully enclosed type.

## A wide range

The massive range covers scraping, cutting metal, ceramics, and of course, wood as well as sanding so I looked at the more basic Piranha and Nail Buster Extreme.

The Piranha has a heat-treated blade, much the same as a hardpoint hand saw,

but is still prone to damage if it comes into contact with metal or masonry. However, it works well across hard- and softwoods and on plastics such as waste and down pipe.

I found the blade to be durable, very sharp and fast-cutting in timber, even with its fine-tooth pattern, retaining its edge well.

For increased durability the Nail Buster blade has a wavy-set hack saw profile with a titanium coating. It can be used on fibreglass, gypsum and non-ferrous metals and of course, as the name suggests, nails. For reclaimed timber or cutting into work already in situ, it's an ideal choice. I used it to cut some skirting back after a new fireplace was installed, cutting cleanly through the timber and into the plaster behind without dulling. However, I found that even as durable and hard as these Nail Busters are, the newer hardened screws can still take the edge off of them so mild steel and softer

metals are its forte if it is to last.

It also has a finer tooth pattern than the purely wood-only styles so the cut, while clean, was marginally slower. The range includes some very affordable blade options from 10-63mm wide and 42-67mm depth as well as some pricier specialist ones, including diamond-coated for tiles and glass.

## In summary

With such a wide range and quality, Smart has certainly made life easier, covering pretty well every model of machine out there into the bargain. **AK**



The Multifix head is designed to fit pretty well every manufacturers' machines

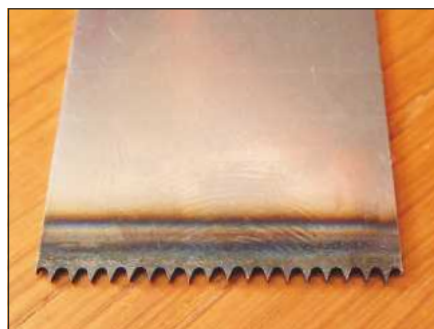

The Piranha blade has sharp hardpoint teeth, ideal for hard- and softwoods



Using the Nail Buster blade allows plunging cuts through into the plaster below



It's easy to make long freehand cuts with the Smart blades



The resulting finish is clean and smooth

## SPECIFICATION

### BLADE CUTTING TYPES

hardpoint, metal, diamond, ceramic, scrapers

**BLADE WIDTHS** 10-63mm

### BLADE STYLES

straight, cranked fan, crescent

## VERDICT

A great range of multi-tool blades at a reasonable price

**PROS** ■ Fast cutting  
■ Different blades for different materials

**CONS** ■ Can be expensive  
■ Some blades can be easily damaged on some materials

**VALUE FOR MONEY** ■■■■■■

**PERFORMANCE** ■■■■■■

## FURTHER INFORMATION

- SMART Tool Group
- 01245 216 540
- [www.smart-toolgroup.com](http://www.smart-toolgroup.com)

Think Black & Decker Workmate and then some because this little workstation is a bit special

# Kennedy Benchtop Workstation



£41.99



The main tray slides out from the back of the table

## SPECIFICATION

Includes two trays to store tools and small parts. Full graduated working surface with channelled chuck block guides. Includes four adjustable chuck blocks and profile adaptor blocks. Mounting holes in the feet of the workstation allow it to be fitted to a workbench if required

## VERDICT

Compact, portable with carry handle and easy to store

- PROS**
- Compact but with decent storage and capacity
  - Double storage areas

- CONS**
- Needs some care not to over-tighten the vice jaws

**VALUE FOR MONEY** ■■■■■■  
**PERFORMANCE** ■■■■■■

## FURTHER INFORMATION

- Cromwell Tools
- [www.cromwell.co.uk](http://www.cromwell.co.uk)

I guess you could say the Kennedy Benchtop Workstation doffs its cap in the general direction of the Black and Decker Workmate as B&D has had its own similar benchtop model at some stage, but this Kennedy model goes that bit further and in turn becomes a pretty decent little work aid.

It does a good job of securing work in the jaws or the clamping blocks without ramping the pressure excessively.

The melamine-coated MDF top has various dimensions and angles marked on as well as a pair of T slots routed and screwed into each jaw to house the adjustable clamping blocks for securing wider work. Round pieces can be secured vertically or horizontally using the V profile and removable shoes.

You do have to be aware that the handles for the main jaws can impart a lot of clamping pressure that could easily damage these blocks or the T slots so you have to take things a little steady here and realise that this isn't a trade or professional piece of kit. Taken steadily,

however, it secures very well within the jaws, and under nipping load the surface clamps hold well enough without slippage.

## Storage solutions

But what sets it apart are the built-in neat storage solutions. Pulling out from the rear is a drawer complete with a steel lidded compartment for storing the clamping blocks, that is of decent enough size to hold a small set of hand tools in the main area.

A further compartment is deep enough to hold a 10.8V battery drill, its charger and a few accessories. The rubber feet rotate away to allow it to drop out from below for easy access and to prevent it filling with debris as you work with the vice jaws. And it makes a pretty decent sawing platform too.

## Summing up

This is a very useful little aid, especially around the home, as it will keep a decent set of basic kit to hand as well as holding the work while you use it, making it pretty versatile as well as transportable. **AK**



A small storage compartment holds the clamping pads



Rotating the feet outwards reveals fixing holes if required



It also allows the work surface to be lifted away to access the lower storage



Slide-on shoes allow round work to be held

This is a great little bench for keeping in the van, and it's up in no time

# Keter Folding Workbench

Although constructed mainly from plastic, this bench is incredibly sturdy once it's locked out to its working position and will hold up to 453kg on its surface. Assembly takes less than 30 seconds, with no fitting of parts because everything is built in.

The two red buttons inboard of the grips are pulled in with the thumbs, allowing the legs to drop while at the same time the top concertinas open. The centre web section doubles up as a carrying handle in the closed position, and is then lifted and pushed forwards to lock the side webs and work surface firmly for a solid workbench.

The concertina design also gives the bench a lower shelf area to put tools on as you work as well as housing two very useful quick-release, fast-adjusting clamps.

With a 300mm capacity, these can be used in slots on the top of the bench as solid securing points for workpieces, to free up both hands for cutting, drilling and shaping work. They can also be used separately as standalone clamps. The work area is a pretty impressive 850

× 550mm with a working height of 755mm, and with the splayed leg design, it's a very stable platform for any work.

## In use

I found this to be the case for planing and cutting work, and with such a decent work area, it gives great support for sheet stock, although the top is a little low for planing flat stock on the top over extended periods, but then this isn't a joinery bench.

Resetting the workbench back to its closed position is a breeze too. The centre web is pulled back down and the outer ones pushed in to begin the collapse of the concertina movement, then by lifting the bench from the lower base shelf part of the bench it all folds back in; the tubular steel legs tuck up inside the base. The centre web now becomes the carry handle.

## Summing up

This little bench takes up very little room when folded, making it ideal for working around the home or keeping in the van. **AK**



£75



The leg assembly folds up inside the worktop when stored

The legs are released by two small levers; pull them both at the same time to release the leg frame



This hinged centre web clicks into place to lock the worktop rigidly



It also clicks into the side webs to ensure it stays locked



Two quick-release clamps are stored on board and are locked into slots in the bench top

## SPECIFICATION

TABLE SIZE	850 × 550mm
TABLE HEIGHT	755mm
MAX WEIGHT CAPACITY	453kg
MAX CLAMP CAPACITY	300mm

## VERDICT

A great compact bench with many uses that is designed to last well

- PROS**
- Fast assembly
  - Stores away neatly
  - Good clamping capabilities

- CONS**
- Maybe a tad low for planing work

**VALUE FOR MONEY PERFORMANCE**

## FURTHER INFORMATION

- Keter
- [www.keter.com](http://www.keter.com)

If you thought that Stubai made only carving tools, then think again...

# Stubai chisels range

**£77.89**  
for a box of six



These handles are not only different from any others I have seen, but so comfortable! Although they have a plastic core and also a plastic striking cap with a rubberised washer below to give them more durability for use with a hammer, what sets them apart is their moulded cork main grips. These seem to be impregnated with a resin for a firm and solid feel but still retain the warmth and comfort of cork and they don't slip in the hand. A couple of flats on either side help keep them from rolling off the bench. Replacement handles are offered but these seem durable enough to last. Stubai has come up trumps with the blades too. There's a polished finish to both the bevel and back faces with no sign of

any grinding marks visible. But the fineness of the lands will be of more interest to those users looking for finer jointing applications, such as dovetailing, and are on a par with the likes of Lie-Nielsen, Veritas, Robert Sorby and Ashley Iles, although the 6mm one has a slightly thicker land compared to the wider ones. This is probably to bolster it up a little as all the blades are slender in their length.

### In summary

Working each blade to check the flatness and ease of initial preparation was a procedure with excellent results; a few strokes on each is enough to get the edge ready for honing, and from there, the edge is perfect.

I mentioned the plastic striking cap, and although it holds up well, the finer style that these chisels have lends them more to bench tools for finer joinery and cabinetry rather than constant heavy hammer striking. Mallet work is where it's at if you need to strike them. Paring work is especially good, and testing them on end-grain oak, maple and ash gave great results. **AK**

## SPECIFICATION

**STEEL ROCKWELL** 62Rc  
**BLADE SIZES** 4-34mm

## VERDICT

Great for paring work and easy to get the perfect edge, although slightly let down by the plastic striking cap

- PROS**
- Fine lands
  - Unique cork handle
  - Replaceable handle

- CONS**
- Plastic striking cap may not hold up under repeated hammer work

**VALUE FOR MONEY**   
**PERFORMANCE**

**FURTHER INFORMATION**

- Johnson Tools
- [www.johnsonstools.co.uk](http://www.johnsonstools.co.uk)



The 6mm chisel (right) has slightly thicker lands than the rest of the set



The plastic striking cap has a rubber shock absorption washer below it



The backs are flat enough to hone quickly straight from the box



End-grain paring on a piece of beech is a cinch with these slender blades

TIMBER SUPPLIES, COURSES & SPECIALIST EQUIPMENT

**Allan Calder's Ltd**  
**Sandpaper Supplies**

Unit 2B, Churnet Works, James Brindley Road, Leek, Staffordshire ST13 8YH.



We are supplying top quality brands of sanding abrasives for all types of Wood Turners, Joiners & Cabinet Makers.

Web: [www.sandpapersupplies.co.uk](http://www.sandpapersupplies.co.uk)

email: [sandpapersupplies@yahoo.co.uk](mailto:sandpapersupplies@yahoo.co.uk)

Tel: **01538 387738**

**Woodturning & Woodworking Courses**

One or two day courses available

**Just Wood Norfolk**

By Tutor with over 30 years experience in wood turning, cabinet making, antique restoration, wood machinery, joinery and the timber industry.

Courses arranged to suit & situated in Norfolk  
Please call for more details.

Telephone Peter on **01493 782408** • e: [luckymayhew@gmail.com](mailto:luckymayhew@gmail.com)  
or see our website: [www.justwoodnorfolk.co.uk](http://www.justwoodnorfolk.co.uk) for more details

**THE CHIPPENDALE INTERNATIONAL SCHOOL OF FURNITURE**



Thirty years teaching furniture design, making and restoration



[www.chippendaleschool.com](http://www.chippendaleschool.com)

**Unloved?  
Unuseable?  
RESTORE IT!**

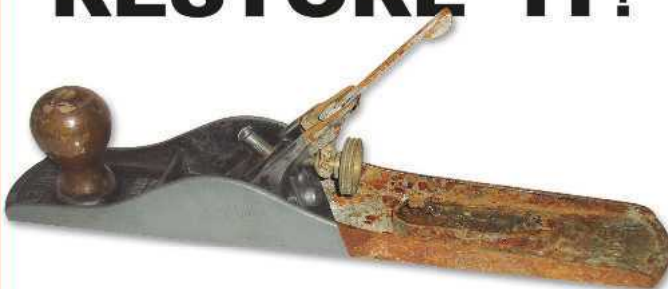

Stanley No.5 'before & after' photo courtesy Peter Hemsley – The ToolPost

**Restore Rust Remover & Restore Rust Remover Gel**

Remove only the rust leaving sound metal unaffected. Cleans and brightens brass and nickel plating. See more stunning 'before & after' examples on our website photo galleries. Find local and international stockists on the website.

Shield Technology Limited.  
Unit 69, Grimsby Business Centre  
King Edward Street,  
Grimsby, DN31 3JH

Tel: +44 (0)1472 360699  
Fax: +44 (0)1472 324685  
Email: [info@shieldtechnology.co.uk](mailto:info@shieldtechnology.co.uk)  
[www.shieldtechnology.co.uk](http://www.shieldtechnology.co.uk)

Distributor enquiries welcome

**SHIELD TECHNOLOGY**  
Guarding Against Corrosion

**SURREY TIMBERS Ltd**

*Your One-Stop Wood Shop*

Hardwood Timber Merchant  
stocking local & Imported Timber



Buy one piece or one pack!

Please come & select from our range:

**OAK, YEW, WALNUT, SAPELE, APPLE, MAPLE, SYCAMORE & More!**

All welcome • Woodturners • Joiners, Cabinetmakers  
Call in and see our huge range at: Loseley Park, Guildford GU3 1HS

**01483 457826 or 07795 663792**  
[www.surreytimbers.co.uk](http://www.surreytimbers.co.uk)

## WOOD FINISHES, SPECIALIST TOOLS & EQUIPMENT



### SPRAY-WAX

High quality oil-wax finish - especially developed for professional users!

- > Extremely tough and hardwearing
- > Very water and dirt resistant
- > Suitable for children's toys (EN 71.3)
- > Microporous, breathable finish, which does not crack, peel, flake or blister



Call or visit website for stockists.



+44 (0)1296 481 220  
www.osmouk.com



## TOOLS WANTED

**Top Prices Paid For Quality Hand Tools**  
carving tools, chisels, turning tools  
norris planes (and similar), metal planes  
green tools, any nice old hand tools...

email photos to: [info@oldtools.co.uk](mailto:info@oldtools.co.uk)  
or bring tools to: Bexhill - 01424 217893



## Dowelmax

**The ultimate doweling jig for furniture makers**

**Brings production technology to the small shop**  
*"Fast, accurate and a joy to use, a superb tool"*

Visit: [www.dowelmax.co.uk](http://www.dowelmax.co.uk)

or telephone: **01352781168 • 07773718758**

**Dowelmax Classic Metric and Junior Metric in stock**



## The Wood Veneer Hub

[www.thewoodvenerhub.co.uk](http://www.thewoodvenerhub.co.uk)

We provide the highest quality:

- Decorative, Exotic & Burr Veneers
- Coloured & Smoked Veneers
- Constructional Veneers
- Peel & Stick Veneers
- Tools & Accessories

Visit Us: Unit 4 Eden Court, Eden Way  
Leighton Buzzard, Bedfordshire, LU7 4FY

+44 (0) 1525 851166

[sales@thewoodvenerhub.co.uk](mailto:sales@thewoodvenerhub.co.uk)

## CAST IRON STOVES

**22**  
Great Looking Styles

BUCKINGHAM  
£298.80

Selling Top Quality Stoves in the UK for over 20 years



**Burn Wood or Coal**  
Big Stocks of Flue Pipes & Accessories in-store

All Stoves conform to EN13240



**FIT NOW FOR CHRISTMAS**



WENTWORTH £395.98



REGAL II £442.80



BARREL £250.80

**SEE THE FULL RANGE IN-STORE OR ONLINE**

**65 SUPERSTORES NATIONWIDE**

Mon-Fri 8:30-6:00  
Sat 8:30-5:30  
Sun 10-4

[machinemart.co.uk](http://machinemart.co.uk)  
MAIL ORDER: 0115 956 5555

**Machine Mart**



COURSES, TIMBER SUPPLIES & SPECIALIST EQUIPMENT



The original milk paint, for authentic colour in all your woodworking and restoration projects.

Chemically safe Historic Paints since 1974

Quote 'WWoffer' for 10% off your first order

The Blueberry Store  
New England Interiors  
Folk Art-Americana

[www.blueberrystore.co.uk](http://www.blueberrystore.co.uk)



**House of Brass**  
CLASSIC TO CONTEMPORARY ARCHITECTURAL FITTINGS SPECIALISTS

SHOWROOM: NOTTINGHAM NG1 3NA  
Tel: 0115 947 5430 (24 HRS)  
Web: [www.houseofbrass.co.uk](http://www.houseofbrass.co.uk)  
FREE CATALOGUE OR VIEW ONLINE

# TREE STATION

Quality English Sawn Timber:

- » Rough sawn or planed
- » Wide variety of species and thicknesses
- » Sustainably grown and kilned



Please get in touch or visit our website  
[www.treestation.co.uk](http://www.treestation.co.uk) - 0161 2313333



**Tewkesbury Saw Company Ltd**

## Spindle Moulder Cutters & Limiters

*Made to Order!*

- Quick turnaround
- Able to supply to fit most types of blocks
- Many low priced standards from stock

**Tewkesbury Saw Co. Ltd.**  
Newton Trading Est. Tewkesbury, Glos. GL20 8JG  
Tel: 01684 293092 • Fax: 01684 850628  
[www.tewkesburysaw.co.uk](http://www.tewkesburysaw.co.uk)

## ANDREW CRAWFORD

box making courses in the Shropshire hills ...

"The weekend course I attended was an absolute delight ... Andrew's calm careful explanations and demonstrations made everything seem so easy and logical ..."

- ◆ weekend courses
- ◆ 'gold' 5 day courses
- ◆ one-to-one tuition



◆ 01694 781318  
[www.box-making.com](http://www.box-making.com)

## SHOP GUIDES

**MAIL ORDER  
NARROW BANDSAW  
BLADES  
MANUFACTURED TO  
ANY LENGTH  
PHONE NOW FOR QUOTATION  
OR PRICE LIST**

**TRUCUT**  
Spurside Saw Works, The Downs,  
Ross-On-Wye, Herefordshire HR9 7TJ  
[www.trucutbandsaws.co.uk](http://www.trucutbandsaws.co.uk)  
Tel: 01989 769371  
Fax: 01989 567360

TOP QUALITY - LOW PRICES  
**VSM - VITEX ABRASIVES**

KK532F Starter Pack (4 Metres) £12.95  
inc. VAT and UK post. 1/2 metre each of grits  
80, 120, 150, 180, 240 320, 400, 600

Also the NEW \*GRIP - A - DISC\*  
**Power Sanding/Finishing System**  
Plus lots of Belts, Discs, Stars, Low cost KK114

We also stock WOODTURNERS SUPPLIES  
Timber/Bowl Blanks/Tools/Waxes/Finishes  
Glues/Chucks/Glassware/Cutlery/Sundries.  
SAE FOR CATALOGUE  
*Jill Piers Woodturning Supplies*  
2 Kimberley Villas, Southmill Road,  
BISHOPS STORTFORD, HERTS CM2 3DW  
Tel/Fax: 01279 653760

**BERKSHIRE**

**WOKINGHAM TOOL  
COMPANY LTD**

97-99 Wokingham Road  
Reading, Berkshire RG6 1LH  
Tel: 0118 966 1511  
[www.wokinghamtools.co.uk](http://www.wokinghamtools.co.uk)  
H. P. W. CS. BS. A. D. MO.

**LEEDS**

**D.B. KEIGHLEY  
MACHINERY LTD**  
Vickers Pleace, Stanningley,  
Leeds, LS28 6LZ  
Tel: (0113) 257 4736  
Fax: (0113) 257 4293  
[www.dbkeighley.co.uk](http://www.dbkeighley.co.uk)  
P. A. CS. BC. MO.

**JET** **SI** **SEDGWICK**

*David Charlesworth* Tool tuning and fine furniture making courses

Revolutionise your hand tool skills with David's five day Tool Tuning course; ultimate plane tuning, chisel preparation and planing skills. Subsequent courses cover Dovetailing and Drawer Making/Fitting. Five day courses run from April to August.

**NEW Weekend Courses from September 2014**  
David is a legend of the UK woodworking scene and has a wonderful teaching workshop in an idyllic location in Hartland, North Devon.

See website for full course details & release date of David's New DVD

Contact David on:  
01237 441288 or email: [davidcharl@aol.com](mailto:davidcharl@aol.com)  
[www.davidcharlesworth.co.uk](http://www.davidcharlesworth.co.uk)

## WEB GUIDE

**WEALDEN TOOL COMPANY**

Router cutters  
Spindle tooling  
Bandsaw, jigsaw & circular sawblades

Online catalogue & ordering  
[www.wealdentool.com](http://www.wealdentool.com)

[www.getwoodworking.com](http://www.getwoodworking.com)

## DIAMOND SHARPENING & CHAINSAW DISCS

[www.StarkieSharp.com](http://www.StarkieSharp.com)  
The Diamond Sharpening Specialists

- Better Prices
- More Information
- Visit us at 40+ Shows

**DMT**  
**Diamond Sharpening Perfection!**

Much safer, smoother carving with up to 44 Teeth cutting fast at 10,000+ RPM.

**KING ARTHUR'S TOOLS**  
**KATS**  
Chainsaw Discs

**The Ultimate Power Carving Experience!**

Cut, Carve, Shape, Notch, Trench & Groove in Seconds! Massively increases productivity!

Quote Code SSTWW6 at checkout for FREE Universal Nut worth £6.95

Shown Lancelot & Squire in Tandem  
Richard Starkie Associates,  
Timber Cottage, Wistow, Leicester, LE8 0QF Email: [sales@starkies.com](mailto:sales@starkies.com)  
[www.StarkieSharp.com](http://www.StarkieSharp.com)

## MUSICAL INSTRUMENT MAKERS

Musical Instrument Makers' & Repairers' Supplies

**TOUCHSTONE TONEWOODS**

Largest selection of tonewoods, tools & parts in the country. Visit our website or order our catalogue. Callers welcome

Touchstone Tonewoods, Albert Road/North, Reigate, RH2 9EZ  
Tel: 01737 221064 Fax: 01737 242748  
[www.touchstonetonewoods.co.uk](http://www.touchstonetonewoods.co.uk)

## CLOCKS

**Woodworking Materials**  
*Large selection of products!*

- ✓ Clocks & Accessories (Quartz and Mechanical)
- ✓ Barometers
- ✓ Thermometers
- ✓ Cabinet furniture
- ✓ Screws
- ✓ Plans
- ✓ Kits
- ✓ Polishes
- ✓ Adhesives
- ✓ Abrasives etc.

For FREE catalogue please contact:

**Chris Milner Woodworking Supplies**  
(Dept.TW) Beresford Lane, Woolley Moor, Nr. Alfreton Derbyshire DE55 6FH  
Tel/fax: (01246) 590 062  
Email: [milnerwoodwork@aol.com](mailto:milnerwoodwork@aol.com)

**To advertise here...**  
...call David on **01689 869 867**  
[david.holden@mytimemedia.com](mailto:david.holden@mytimemedia.com)

# MARKETPLACE



Our **FREE** classified advertisement service

## FOR SALE

**Elektra Beckum bandsaw model BAS315-4 GWN55** in excellent condition with Elektra Beckum dust extractor SPA1000 complete with dust bag, hoses, etc. £400  
**01795 873 589 (Kent)**

**Myford wood lathe**, 32in bed on stand, 6in faceplates, box of tools, various turning blanks. Call to make an offer  
**01255 425 058 (Essex)**

**Axminster cast-iron mitre trimmer**, as new; £60. Electric motor, 550W, 240V, 1,400 rpm; £40  
**01162 415 548 (Leics)**

**NuTool HS1500 table saw**; £50  
**01543 424 434 (Staffs)**

**7in woodworking vice** – £55; carpenter's toolbox – £30; skew planes (Record and Stanley) – £230  
**02086 414 238 (Surrey)**

**Scheppach HS100E circular saw bench**. Unused; £120. Buyer collects  
**01233 638 039 (Kent)**

**Incra LS precision routing system**. Positioner, jumbo right angle fence, flipstop and hinge crafter, box jointer router table; £385  
**01777 870 309 (Newark)**

**Jet wetstone grinding system** with extra accessories and special base unit. Buyer collects; phone for details.  
**01844 344 912 (Bucks)**

**Hegner HBD200XL woodturning lathe** with electronic speed, TO 3800 Multistar Duplex chuck, Vicmarc VM90 chuck, live and dead centres; £950. Buyer collects. Call for details  
**01767 316 925 (Beds)**

**Axminster woodturning lathe** (240 × 330mm). Extras include 16 chisels, chuck indexing ring and hole boring kit; £150. Buyer collects  
**01223 503 860 (Cambridge)**

**Multi 9½in planer with thicknesser attachment**, two blade cutterblock, 2HP motor and cast-iron bed, with DeWalt extractor; £250  
**07881 971 737 (Devon)**

**Scheppach Basato 4 bandsaw**, little used with four unused spare blades; £400  
**01912 367 455 (Durham)**

**Bowl-turning blanks** plus a large collection of exotic wood in a variety of sizes. All blanks at least 18 years old. Being sold by a retired turner – phone for list and details  
**01747 838 770 (N. Dorset)**

**Harrison Graduate woodturning lathe**, 54in bed length, 18in over the bed, Speed Genie variable control, centre steady, 12 and 8in faceplates, Axminster Goliath chuck and jaws, four toolsets, four 4in faceplates; £1,500 ONO, buyer collects  
**01772 613 044 (Lancs)**

**Exotic Hardwood**. Short boards, 36in and 24in × 6 × 2, £6 each; part boards £5. Some turning blanks 2 × 2 × 10in. Buyer collects  
**0208 675 0132 (London)**

**Hardback books**. Time Life (Canada and USA), BBC and other assorted Golden Homes magazines. Offers – buyer to collect  
**01912 658 397 (Newcastle)**

**200 × 300m veneers**: six Santos rosewood; six Canadian elm eight crown chestnut; five American cherry. Phone for details  
**01243 552 524 (W. Sussex)**

**Screwfix 305mm combination dovetail jig**. Complete with router bush, cutter and instruction leaflet. Never used; £25  
**07973 698 170 (N. Yorkshire)**

**Scheppach TS2000 table saw** with sliding carriage. Very good condition; £250  
**01443 205 469 (Mid Glamorgan)**

**Record CLI Lathe**. Four-speed belt change, bowl turning attachment, 914mm between centres, solid bed bars, ¾ × 16tpi, 1MT. Includes Supernova chuck ¾ × 16tpi, two sets of jaws, woodworm screw and Multistar micro chuck ¾ × 16tpi. Very good condition; £275 + P&P  
**01482 706 283 (E. Yorkshire)**

**Triton 2000 Workcentre**. Comes with wheel kit and dustbag fitted with

Triton 235mm saw, workshop space needed; £300  
**01908 569 217 (Milton Keynes)**

**Sandpaper and emery cloth**. Various grits, rolls and sheets. Call for further details  
**01613 395 161 (Lancs)**

**Record 405 Multi-plane** with 37 cutters and nosing – hollow and round bases. Excellent condition; £95. Stanley (USA) Compass plane No.20, excellent condition; £60  
**01493 785 575 (W. Sussex)**

## WANTED

**Woodworker magazines**. Pre-1951 plus 1984–1986. Grandfather collecting for cabinetmaker grandson  
**01493 368 180 (Norfolk)**

**Spiers/Norris/Henley planes** wanted by private collector; any quote beaten. Ring Ron Lowe on  
**01530 834 581 (Leics)**

**Woodworking hand tools**, especially old wood and metal planes, wanted by collector. Write to Mr B Jackson, 10 Ayr Close, Stamford PE9 2TS or call **01780 751 768 (Lincs)**

**Woodworking tools**: planes by Norris, Spiers, Mathieson, Preston, Slater, etc. brass braces, interesting rules and spirit levels; top prices paid, auction prices beaten  
**01647 432 841 (Devon)**

## USE THIS FORM TO BOOK YOUR **FREE** AD

**The Woodworker**  
MARKETPLACE

- This space is available only to private individuals wishing to buy or sell woodworking machinery and tools.
- The maximum value of any item for sale must not exceed £500. A small fee is payable for items offered at over £500; please ring 01689 869 852 for details.
- Each coupon is valid for one free insertion in the next available issue.
- The publisher accepts no responsibility for errors or omissions in this section.

Please publish this advertisement in the next available edition of *The Woodworker*. I am a private advertiser and have no trade connections.

PLEASE TICK: FOR SALE  WANTED

**My advertisement (max 20 words please) reads as follows:**

Name \_\_\_\_\_  
Address \_\_\_\_\_  
\_\_\_\_\_  
Postcode \_\_\_\_\_ Daytime tel no. \_\_\_\_\_  
Signature \_\_\_\_\_

\_\_\_\_\_  
\_\_\_\_\_  
\_\_\_\_\_  
\_\_\_\_\_  
\_\_\_\_\_

Please write your advertisement in **BLOCK CAPITALS** and send it to: **The Woodworker Marketplace, MyTime Media Ltd, Enterprise House, Enterprise Way, Edenbridge, Kent TN8 6HF**. You can also email your free ad to: **thewoodworker@mytimemedia.com** **Send/email a photograph of your item and we'll include it with your ad for FREE**

# Inside out

We look at the front cover from the June 1947 issue of *The Woodworker*, a great example of getting value for money by utilising valuable newsprint

good husbandry and woodworking are well suited, the only downside is my reluctance now to throw anything away.)

## Step-by-step

So, there are no photos of what's inside the journal, nor even a few headings as to what else might be covered in this particular issue (as it happens it was pretty standard, and not a cupboard special.) On an information level this cover has a lot going for it, and the actual step-by-step instructions for fitting a pair of cupboard doors are very good indeed, especially the note on the treatment of rebated stiles (figure 8). For the home amateur woodworker – indeed for any woodworker some might say – fitting the doors to a gap of the thickness of brown paper (figure 4) is fairly ambitious, but it just shows the sort of standards that the cabinet trade was working to back then.

## Tight fit

While today's fine furniture makers will work to these sorts of tolerances as a matter of course, I've found that it's a good idea to adopt them when working with softwood that is destined for a modern centrally heated home. The timber shrinkage, especially on doors that meet like the ones illustrated here, can be almost frightening sometimes, so a really tight fit should be aimed for; the doors will inevitably ease in a day or two and be almost too comfortable after a couple of weeks.

## Door experiences

If anyone has had any unusual or unlikely experiences with doors recently, I'd love to hear about it. Just drop me a line on [mark.cass@mytimemedia.com](mailto:mark.cass@mytimemedia.com) and we'll see what's what.

*Mark*



There can't be many magazines on the market today which feature content on the front cover, but perhaps they should consider it? *The Woodworker* is keeping its powder dry on the matter...

While most front covers these days concern themselves with advertising the contents within, this page one copy of *The Woodworker* from June 1947 is a very good

example of getting value for money. In the resource-stretched years after World War II, pretty much everything was in short supply, and newsprint no exception. Making full use of what little was available was something approaching a national pastime during these years, according to my granny who brought us up in this very same tradition (personally I'm grateful for her instruction;

More from *The Woodworker* archive next month...

# FFX TOOL SHOW 2016

## THE UK'S FAVOURITE TOOL SHOW IS BACK.

**LOWEST UK PRICES - GUARANTEED!**

**50,000SQ FT OF THE BEST BRANDS  
UNDER ONE ROOF**

Live demos from industry experts, unbeatable deals,  
competitions, masterclasses *and more!*

**26th Feb | 27th Feb | 28th Feb**

Kent Event Centre, Maidstone, Kent, ME14 3JF

**REGISTER NOW**

**FREE TICKET AT  
FFX.CO.UK**

**REGISTER NOW**

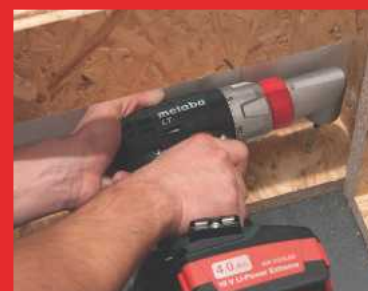

**THE BEST BRANDS UNDER ONE ROOF**

 **BOSCH**  **Makita**  **FESTOOL**  **DEWALT**  **schepach**  **trend**  **AND MORE!**

# Introducing the New Range of Woodturning Chucks and Jaws

We are extremely proud to introduce the new range of Record Power woodturning chucks and jaws. This exclusive range has been developed using Record Power's extensive experience and knowledge of woodturning in conjunction with a group of highly experienced professional and hobby woodturners to bring you the ultimate in quality, versatility and value.



**Precision Engineered Gears**  
Super Geared True-Lock™ technology ensures high levels of accuracy to provide smooth and solid operation.



**Jaw Fixing System**  
The SC3 and SC4 feature a jaw fixing which will not only fit the Record Power series of Jaws but is also fully compatible with Nova and Robert Sorby brand jaws.

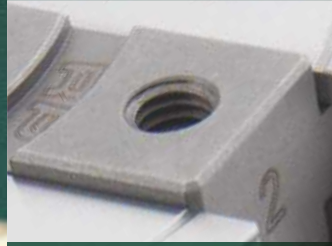

**Heavy Duty Jaw Slides**  
The improved and enlarged jaw slides give unsurpassed holding power and load bearing ability. They are made from high tensile steel, reinforced with nickel and copper and heat-treated to ensure superior strength.



**Sealed Backing Plate with Full Indexing**  
The SC4 features a strong backing plate to protect the gear mechanism from dust and 72-point indexing around the full circumference.

**SC3 Geared Scroll Chuck Package** **Only £99.99**  
Now includes 2" Faceplate

**SC4 Professional Geared Scroll Chuck Package** **Only £129.99**  
Now includes 2" Faceplate

**15% OFF**  
All jaws when 3+ sets bought

Prices valid until 31.8.2016

See online for full details

**RECORD POWER**  
ESTABLISHED 1909®

Over  
**100**  
years  
Experience • Knowledge  
Support • Expertise

**RECORD POWER**  
ESTABLISHED 1909  
**STARTRITE**  
**CORONET**  
**BURGESS**

Incorporating some of the most famous brands in woodworking, Record Power have been manufacturing fine tools & machinery for over 100 years. Built to last we provide support for thousands of machines well over 50 years old, which are still in daily use. Testimony to the sound engineering principles and service support that comes with a Record Power product.

[www.recordpower.co.uk](http://www.recordpower.co.uk) Tel: 01246 571 020