

23 Gorgeous Home Accents You Can Make

SPRING 2017  
ISSUE 66



SCROLLSAW

# WOODWORKING & CRAFTS

## CRAZY FOR CATS

*Fun Feline  
Patterns*

**Whimsical  
Toys & Puzzles  
To Make On Your Saw**

**Quick & Easy  
Air Plant Holders**

**Turn Coloring  
Book Pages into  
Awesome  
Projects  
We Show  
You How**



DISPLAY UNTIL APRIL 17, 2017

\$7.99



FOX CHAPEL  
PUBLICATION

Family Owned and Operated



# THE WOODEN TEDDY BEAR COLLECTION

In Business Since 1995

WORSHIP



- Thousands of Patterns
- New and Discounted Patterns on the Web Site
- Flying Dutchman Scroll Saw Blades (as low as \$29.40 per gross)
- Olson Scroll Saw Blades (as low as \$23.88 per gross)
- Olson Band Saw Blades
- Forstner Bits
- Woodburning Tools
- Clock Fit-Ups
- Acrylic
- Small Wood Parts
- Scroll Saw Tape

## Patterns, Plans, & Supplies for the Woodworker.



**Free Catalog**  
**1-888-762-9149**



[www.woodenteddybear.com](http://www.woodenteddybear.com)

# Seycos

The Scroll Saw Specialists, INC.  
<http://www.seycos.com>

**1-800-462-3353**

**.....The Link Drive Authority**

**"The only company in existence with over 30 years experience representing TOP QUALITY Link Drive Scroll Saws."**



**Excalibur**  
BY GENERAL INTERNATIONAL

**Contact  
 SEYCO  
 for  
 current  
 specials**

**800-462-3353**

**[www.seycos.com](http://www.seycos.com)**

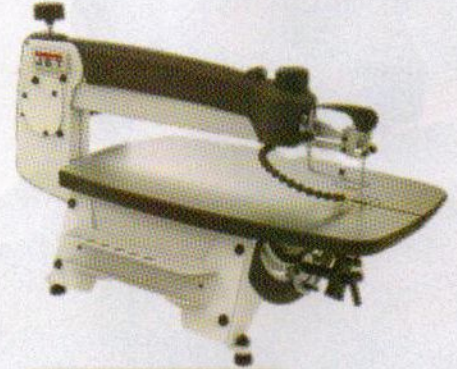

**JET**

**• SEYCO'S UNIQUE Sanding Accessories •**



**DS-01 Flex Drum Kit**  
 (Use on your motor)



**GWSC-10 Dual Flex Drum Sander**



**SFW-06  
 Finger Wheel  
 Finish Sander**

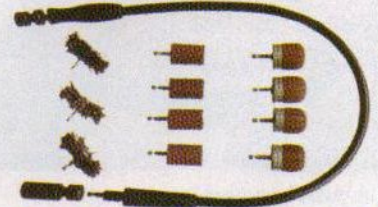

**GWSC-AC Flex Shaft  
 Sanding accessory kit**



**GWSC-ST Stand  
 W/Accessory Tray**

**GWSC-10 Dual Flex Drum Sander . . . . . \$274.95\***  
 Features our 1800 RPM Baldor motor with our custom designed arbors & 1 ea - 80 grit & 120 grit flexible padded sanding sleeves.  
**DS-01 Flex Drum Sander kit . . . . . \$37.95\***  
 Includes a Seyco custom arbor & 1 ea 80 & 120 grit padded sleeves with 5/8" X 1/2" split bushing.  
**GWSC-ST Stand for GWSC-10 . . . . . \$89.95\***  
**SFW-06 Finger Wheel Finish Sander . . . . . \$64.95\***  
 6"D X 2"W features 1/8" strips for a non aggressive finish sand.  
**GWSC-AC Flex Shaft & accessory kit . . . . . \$179.95\***  
 Rugged flex shaft with quick connect adapters; 4 BNS round end flex sanders; 4 mini flex drum sanders - (80; 120; 180 & 220 grits) & 3 mini flutter wheels (120; 180 & 220 grits).  
**10-030 General 1HP Mobile Dust Collector . . . \$325.00\***  
 Complete w/Easy Clean filter. LIMITED SUPPLY AT THIS PRICE!  
 \* PLUS SHIPPING



**10-030 General  
 Mobile Dust  
 Collector**

**VISIT SEYCO'S WEBSITE AT: [www.seycos.com](http://www.seycos.com) or CALL 1-800-462-3353  
 and chat with one of our real people!**



41

## FEATURES

### 24 Creative Cuts

By Kathleen Ryan  
Three-dimensional scroll saw art with a twist by David Hobbs

### 58 Spring Round-up

By Kathleen Ryan  
Inspiration for a bright new season

52



## PROJECTS

### 26 Spring Gathering

By Janette Square  
Design by Bruce Worthington  
Complex intarsia features a variety of beautiful birds

### 36 Woodrow the Woodpecker

By David Wakefield  
Animated avian ascends any wall with ease

### 49 Easy Salt & Pepper Shakers

By Gary MacKay  
Use scrap wood to make these functional dinner table decorations

### 52 Desktop Rockets

By Bob Gilsdorf  
Simple design ignites imagination

### 54 Kitty Basket

By Kathy Wise  
Cute intarsia design introduces a simple way to create a basket-weave effect

### 60 Hamsa Box

By Carole Rothman  
Combine colorful hardwoods and veneer to make a meaningful gift

### 66 Puppy Coin Bank

By Paul Meisel  
Cut this cute project and have the little ones help you assemble it



31

## PATTERNS

### 31 *Fretwork Heart*

By Sue Mey

Make this wall hanging for Mom or customize it for another special person

### 32 *Air Plant Holders*

By Sue Mey

Compound-cut cool cubbies for these popular plants

### 34 *Cat Puzzles*

By Eric Van Malderen

An assortment of designs purr-fect for the feline lovers in your life

### 41 *Nosy Dragon Shelf Sitter*

By Judy and Dave Peterson

Freestanding puzzle watches you work and defends your desk

### 42 *Duck Wall Hanger*

By John A. Nelson

Instant color lets you finish this project in no time

### 44 *GEX (The Anti-Jigsaw Puzzle)*

By Dave Van Ess

Gecko-shaped tessellating tiles are an addictive toy

### 46 *Fierce Felines*

By Charles Dearing

Create your own pride with these three wild portraits



60



66

## TECHNIQUES

### 20 *Creative Projects from Coloring Books*

By Mindy Kinsey

The coloring fad has a side benefit: the designs are great for woodworking, too!

## SCROLLSAWER.COM

#### • Videos

See Woodrow the Woodpecker (pg. 36) and the Desktop Rockets (pg. 52) in action.

#### • Free Downloads

Download and print the coloring pages we used for Creative Projects from Coloring Books (pg. 54). Plus, save a photocopy and simply download the Duck Wall Hanger art (pg. 42).

#### • Vector Pattern

If you have access to a laser, download the vector version of the GEX pattern and design (pg. 44) and save time by etching it onto the wood instead of transferring it by hand.

#### • Newsletter

Get news, patterns, book reviews, show reports, and more! Sign up for our free quarterly e-newsletter, Short Cuts, at [scrollsawer.com/enews](http://scrollsawer.com/enews). Check out the archive at [scrollsawer.com/category/enews-short-cuts](http://scrollsawer.com/category/enews-short-cuts).



Look for Scroll Saw Woodworking & Crafts on Facebook

Follow us on Twitter, [twitter.com/scrollsawer](https://twitter.com/scrollsawer)



## DEPTS.

4 *Editor's Note*

6 *Letters*

8 *Reader Gallery*

12 *Contest Winners*

14 *Product Review*

16 *Tips & Techniques*

70 *Scroll Saw Basics*

71 *Coming Features*

71 *Ad Directory*

72 *Sawdust*

## COVER

*Gorgeous Home Accents ...* 26, 49, 54, 60, 66, 31, 32, 42

*Crazy for Cats ...* 34, 46, 54

*Whimsical Puzzles and Toys ...* 34, 36, 41, 44, 52

*Quick & Easy Air Plant Holders ...* 32

*Turn Coloring Book Pages into Awesome Projects ...* 20

## True Colors

I come from a long line of crafters—we knit, crochet, embroider, sew, etc. We enjoy the activities for their own sakes as well as to have whatever object we're producing, but we're also somewhat compelled to "keep our hands busy." Some people eat popcorn while they watch movies; my mother crochets washcloths and hats. I color, and have since I was a kid.\*

So I was perhaps the only person in America\*\* who wasn't surprised when coloring for adults became a bona fide sensation. Coloring is relaxing and satisfyingly artsy without being difficult, expensive, time consuming, or messy; of course people love it! So much so that a shortage of colored pencils was rumored.

And, it turns out, coloring books also make good woodworking patterns.

My first inkling came a few years back when John Nelson showed us his pre-colored scrolling projects. Many of his designs are charmingly retro, reminiscent of coloring books from my childhood, and I remember thinking that you could color pictures, glue them to wood, and scroll around them. John takes the idea further by providing the colored art and turning it into toys and home accessories; we've included his pegboard hanger on page 42.

Then our parent company, Fox Chapel Publishing, combined two of my childhood favorites, coloring and stickers, in one great series: Color Your Own Stickers. Perfect, I thought—stick 'em on wood and make Christmas ornaments, jewelry ... all kinds of stuff.

The designs in another Fox series, TangleEasy by Ben Kwok, are intended to incorporate coloring and Zentangle drawing, but I saw them as intarsia and chip-carving patterns. Some of our nature coloring books are indistinguishable from relief-carving patterns. Almost any coloring book can be used for pyrography (woodburning).

We worked with a team of artists to combine all of these ideas into "Creative Projects from Coloring Books" (page 20). I hope it will help you see the woodworking potential in coloring books and serve as a springboard for making your own projects. (I know most of you don't carve, but I included the projects here for additional inspiration.) Of course you don't have to use Fox coloring books, although we have lots of good ones and we've included a few designs to get you started, with more on our website. No need to worry about that colored pencil shortage; as long as you have wood, blades, and a saw, you are ready to tackle a coloring book!

*M. Kinsey*  
Mindy Kinsey  
kinsey@FoxChapelPublishing.com

\*OK, I eat popcorn, too.

\*\*Sure, this is an exaggeration, but, judging by the media coverage, most people were dumbfounded.

# SCROLLSAW woodworking & CRAFTS

Printed in the USA

SPRING 2017

Volume 18, Number 1, Issue 66

1970 Broad Street, East Petersburg, PA 17520

Phone: 717-560-4703 Fax: 717-560-4702

Website: www.ScrollSawer.com

### Our Mission:

*To promote scrolling as an artform and an enjoyable pastime—for all ages and all skill levels.*

Publisher .....	Alan Giagnocavo
Editor .....	Mindy Kinsey
Technical Editor .....	Bob Duncan
Editorial Assistant .....	Kristen Scanlan
Art Director .....	Jon Deck
Contributing Photographer .....	Lindsay Garner
Technical Illustrators .....	Jon Deck
.....	Carolyn Mosher

### Customer Service for Subscribers

Visit [www.ScrollSawer.com](http://www.ScrollSawer.com), call 888-840-8590, or write:  
Scroll Saw Woodworking & Crafts, Subscriber Services,  
1970 Broad Street, East Petersburg, PA 17520

Newsstand Distribution: Curtis Circulation Company  
Circulation Consultant: National Publisher Services  
Printed by Fry Communications

©2017 by Fox Chapel Publishing Co. Inc.  
All Rights Reserved. Printed in USA

### Subscription rates in US dollars:

One year .....	\$24.95
Two years .....	\$49.90

### Canada

One year .....	\$29.95
Two years .....	\$59.90

### International

One year .....	\$34.95
Two years .....	\$69.90

### Display Advertising/Classified Ads

For rates and/or a media kit, please  
call Michele Sensenig at 717-286-0090 or 800-457-9112 x104,  
or e-mail [sensenig@FoxChapelPublishing.com](mailto:sensenig@FoxChapelPublishing.com)

### Wholesale/Distribution

Scroll Saw Woodworking & Crafts is available to retailers for resale on advantageous terms. Contact Wendy Calta (ext. 114) for details.

Identification Statement: Scroll Saw Woodworking & Crafts,  
vol. 18, no. 1 (SPRING 2017) (ISSN#1532-5091) is published quarterly by  
Fox Chapel Publishing Co. Inc., 1970 Broad Street, East Petersburg, PA 17520.  
Periodical Postage paid at East Petersburg, PA and additional mailing offices.  
POSTMASTER: Send address changes to Scroll Saw Woodworking & Crafts,  
1970 Broad Street, East Petersburg, PA 17520.

Publication Mail Agreement #40649125  
Return Undeliverable Canadian Addresses to:  
Station A, PO Box 54  
Windsor, ON N9A 6J5  
[Shannon@FoxChapelPublishing.com](mailto:Shannon@FoxChapelPublishing.com)

**Note to Professional Copy Services — The publisher grants you permission to make up to ten copies for any purchaser of this magazine who states the copies are for personal use.**

# Sloan's Woodshop 888-615-9663

Celebrating our 20th Year in Business

SloansWoodshop.com

## OLSON®

### 5" Pin Less Scroll Saw Blades

#### Regular Skip Tooth Blades

# 3/0, 2/0, 0, 2, 4, 5, 7, 9, 11  
\$ 2.30 a Doz - \$23.00 a Gross

#### Double Skip Tooth Blades

# 3/0, 2/0, 1, 3, 5, 7, 9, 12  
\$2.30 a Doz - \$23.00 a Gross

#### Reverse Skip Tooth Blades

#2/0, 2, 5, 7, 9, 12, 420  
\$2.50 a Doz - \$25.00 a Gross

#### Spiral Tooth Blades

# 2/0, 0, 2, 4, 6  
\$2.50 a Doz - \$25.00 a Gross

#### Flat End Spiral

# 2, 4  
\$3.30 a Doz - \$33.00 a Gross

#### Crown Tooth Blades

# 2/0, 2, 3, 5, 7, 9, 12  
\$3.00 a Doz - \$30.00 a Gross

#### Precision Ground Tooth

# 5, 7, 9,  
\$4.50 a Doz - \$45.00 a Gross

#### PGT Double Tooth

# 5, 7, 9,  
\$4.50 a Doz - \$ 45.00 a Gross

#### Mach Speed Reverse Tooth

# 3, 5, 7, 9  
\$3.50 a Doz - \$35.00 a Gross

#### Thick Wood Blades

# 408-TW  
\$ 3.60 a Doz - \$36.00 a Gross

#### Metal Cutting Blades

# 1, 5, 7, 9, 12  
\$3.60 a Doz - \$36.00 a Gross

### One Gross = 12 Dozen Blades

You can Mix or Match the Same Type

of Blades - For Gross Pricing

All the blades above are  
5" Pin-Less OLSON® Blades

#### We Also Stock

3" Pin-end blades - 2 sizes  
5" Pin-end blades - 8 sizes  
6" Pin-less blades - 4 sizes  
5" Pin-less Jewelers Blades

Many other items listed on our Web Site

### Baltic Birch Plywood

The Best Grade Available - B/BB

12"x12" - Good One Side

#101 - 1/8" Baltic Birch - \$1.55  
#102 - 1/4" Baltic Birch - \$2.35  
#104 - 1/2" Baltic Birch - \$3.40  
#105 - 5/8" Baltic Birch - \$4.45

12"x24" - Good One Side

#107 - 1/8" Baltic Birch - \$3.10  
#108 - 1/4" Baltic Birch - \$4.70  
#110 - 1/2" Baltic Birch - \$6.80  
#111 - 5/8" Baltic Birch - \$8.90

### Hardwood Plywood

12"x12" - Good One Side

#200 - 1/4" Red Oak - \$2.50  
#450 - 1/4" Maple - \$2.50  
#250 - 1/4" Cherry - \$3.00  
#275 - 1/4" Mahogany - \$3.00  
#350 - 1/4" Walnut - \$4.00



### Blade Storage Tubes

Clear Plastic  
3/4"x6"  
Hangtab  
Tops

# TUBE  
\$6.95  
Per Dozen



### 2" Square

Keep the Scroll Saw Blade  
Square with your Table

# SQ2 - \$5.95

### 6" Square

Great for Table Saws  
and Band Saws

# SQ6 - \$9.95



## Olson®

### Scroll Saw Files

They easily shape and sand contours eliminating hand sanding. Files have a tempered spring steel core coated with silicon carbide abrasive. Comes in both Pin-less and Pin-end styles

Each Package  
Contains Two Files

Width-.156"  
Thickness -.056"  
Fine Finish

Made In The USA

#42100 Pin-Less  
#42101 Pin-End

\$5.95  
per pack



### 1-7/16" Clock Inserts

Glass Lens, Stainless Back  
No Dreadful Rubber Gaskets

#CK100 - White Arabic

#CK103 - Ivory Arabic

#CK102 - Gold Arabic

Mix or Match Pricing

1 to 9 - \$5.95 each

10 + - \$5.65 each

30 + - \$5.25 each

More Clock Sizes & Styles  
In Stock - 2", 2 3/4", 3 1/2"

1-3/8" Forstner Bit  
To Drill Mounting Hole  
For 1-7/16" Clock & Photo  
Stock # D1010 - \$ 9.95



### 1-7/16" Photo Insert

Glass Lens, Stainless Back  
# PHOTO-1

1 to 9 - \$2.60 each

10 + - \$2.45 each

30 + - \$2.15 each

16-pc Drum Sanding Kit  
Includes - 1/2", 3/4", 1" & 1-1/2" by  
2" long rubber drums 1/4" spindles  
and 3 medium grit sleeves each  
# D3292 - \$ 14.95



### Needle File Sets

12 piece sets in 2 sizes of files.  
Regular - about 6" long & 1/4" wide  
Mini - 4" long - 1/8" & less in width

Reg - #12pcnf - \$12.95

Mini - #12pcmini - \$7.95



Great for cleaning  
up fretwork  
and burn marks

Both Sets  
include a plastic  
storage pouch

### Precision Pin Chuck

Use mini bits in your drill press  
With 3 collets it holds bits #80 - #40

# PC-1 - \$14.95



### Small Drill Bits

1/16", 3/32", 1/8" Bits - \$5.95 per doz

Numbered Mini Drill Bits

#54, #56, #58, #61, #64, #67, #70, #72

\$7.95 per Dozen

The # 67 is equal to a 1/32" drill bit  
(sorry no mixing sizes of drill bits)

### Do you Love Scrolling

### But Hate Scraping The Paper Pattern Off

### Try Our - Removable Adhesive Paper

Copy your pattern to this paper. Then peel off the paper backing. Stick the paper on your wood or other material.

Cut out your pattern - **Then Simply Peel This Paper Off**

No Spray Glue, No Scraping, No Paint Thinner, No Mess

No Problems - Works in copiers & laser or inkjet printers

Each Sheet Measures - 8 1/2" x 11"

#AP10 - 10 Sheets - \$3.95 #AP100 - 100 Sheets - \$30.00

#AP25 - 25 Sheets - \$9.50 #AP250 - 250 Sheets - \$65.00

### Order Toll Free

1-888-615-9663

## Sloan's

## Woodshop

3453 Callis Road

Lebanon, TN

37090

### SHIPPING & HANDLING CHARGES

Applies only to the 48 contiguous states

\$00.00 - \$40.00 add \$ 6.50

\$40.01 - \$60.00 add \$ 8.00

\$60.01 - \$80.00 add \$10.00

\$80.01 - and over add 15%

TN residents add 9.25% Sales Tax

All Prices Subject To Change Without Notice

Have a Question - Give Us a Call !!!

## Customized Truck Puzzle

The article in *Scroll Saw Woodworking & Crafts* Fall 2016 (Issue 64), "A Tribute to Great Trucks," sent me back 48 years. When I was 16, my father and I bought a 1955 Chevrolet half-ton stepside short box two-wheel drive pickup for \$300, just like the one Eric Van Malderen said he couldn't name.

In my haste and excitement I cut out a  $\frac{3}{4}$ "-thick puzzle, copying his pattern. On closer scrutiny, the truck I owned was a bit different, so I changed the pattern to make the front bumper rounder, the rear bumper square, the rear fender and cargo box shorter, a tailgate latch chain was added, and the puzzle knob between the cab and the bed was flip-flopped to accommodate a gas cap.

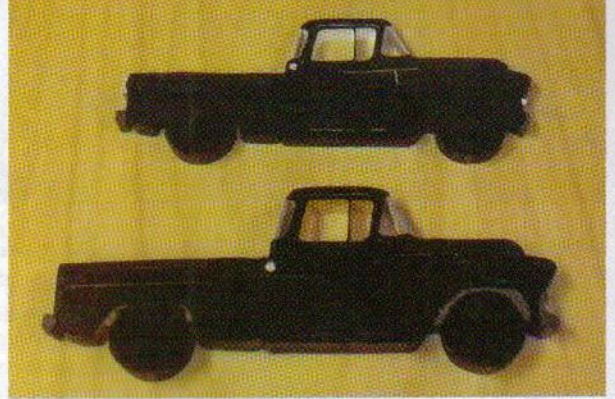

When I customized my original pickup I had its exterior painted black and its interior painted white. Therefore, I painted the redesigned puzzle, cut from  $\frac{1}{2}$ "-thick birch plywood, black and white. I used a #3 crown-tooth blade to tighten the saw kerfs.

**Zed A. Stone**  
Salmon, Idaho

### To Publish or Not to Publish...Toy Guns

We published "Rubber Band Six-Shooter" by Daryl Webb in Fall 2016 (Issue 64). We carefully considered whether to publish the article. In the end, we thought it was an enjoyable way to harken back to a childhood pastime. Here are some responses from our readers:

Regardless of the current events, there are some people that would be opposed to any weapon, including decorative scrolled knives. I think this project falls into the same category as Christmas ornaments. It isn't for everyone, but it makes sense to publish a variety of projects to appeal to a wide variety of interests.

**Randy Gloden**  
Via forum

I believe that encouraging children to play with a toy gun sends the wrong message. We do not want children to think guns are fun or something not to be taken seriously. Also, rubber bands are both a choking hazard to toddlers and can easily be shot at another child's eyes, possibly causing lasting damage.

**David Haugen**  
Downers Grove, Ill.

As a child I had an ivory-handled pistol (which I still have) and a cap gun. However, I really don't believe your magazine should have included the pattern for a realistic-looking gun in this day and age. I think you made a poor choice.

**Joanne Engelhardt**  
Walton, N.Y.

I don't think it was irresponsible to publish the pattern. Whether one chooses to make the gun is a personal decision that I would rather be able to make on my own than have made for me.

**Bill Wilson**  
Via forum



### Fox Hunt

Daniel Bluhm of Zephyrhills, Fla., and James White of International Falls, Minn., were randomly drawn from the participants who located the fox in our last issue (Fall 2016, Issue 64). The fox was hiding on the edge of Paul Meisel's Wooden Advent Wreath on page 56.

Find the fox in this issue, and tell us the page number and location. Two readers randomly selected from all correct replies will receive a \$25 Fox Chapel Publishing gift certificate. Entries must be received by February 23, 2017, to be eligible. *NOTE: The contest fox is an outline drawing that would face left if his feet were on the "ground" (other foxes appearing in SSW&C don't count).*

Send your entry to SSW&C, Attn: Find the Fox, 1970 Broad Street, East Petersburg, PA 17520, or enter online at [www.ScrollSawer.com](http://www.ScrollSawer.com).

### Let's Hear From You

We'd love to hear your thoughts on our projects, ideas for new patterns, scrolling experiences, and woodworking show stories. Write to us at: Letters to the Editor, *Scroll Saw Woodworking & Crafts*, 1970 Broad Street, East Petersburg, Pa., 17520 or e-mail [Editors@ScrollSawer.com](mailto:Editors@ScrollSawer.com).

# MAXIMIZE YOUR ABILITY



## INTRODUCING THE NEW JET® SCROLL SAW

**ONE STEP**  
CLAMPING & TENSIONING

**REMOVABLE**  
LOWER BLADE HOLDER

**ARM TILTS**  
45° RIGHT, 40° LEFT

**LARGE**  
CAST IRON TABLE

SEE MORE AT  
[JETTOOLS.COM/SCROLLSAW](http://JETTOOLS.COM/SCROLLSAW)



727200K

## STAND BEHIND YOUR WORK™



550+ SERVICE CENTERS NATIONWIDE

INDUSTRY-LEADING WARRANTIES

EXPERT TECHNICAL SERVICE



**1. Buck and Doe** Justin Blake of Grant, Mich., was inspired to begin scrolling by his grandfather, Fred Blake. Justin used other people's patterns until he realized that it is easier and cheaper to draw his own. He made *Buck and Doe* from scrap pine and wood stain. View more of Justin's work at [www.facebook.com/BlackBearWoodWorks](http://www.facebook.com/BlackBearWoodWorks).

**2. Gorilla and Baby** John DeFabio of North Massapequa, N.Y., scrolled this intarsia gorilla and baby from a pattern by Robert Hlavacek. It is 2' by 3' and made with various shades of walnut, cypress, and bamboo.

**3. Dog Clock** Christopher Hawkins of Midland, Mich., adapted a pattern by Jeff Zaffino to make this maple and walnut clock.

**4. Peace on Earth** Stephen Garrison of Conyers, Ga., made this punny project after his adult son declared that he wanted "peace on Earth" for Christmas. Stephen glued burl walnut veneer to the back and bottom and then attached the floaters (centers of P, E, and A). Contact Stephen at [fretknott@yahoo.com](mailto:fretknott@yahoo.com).

**Share Your Latest Work!**

Send a slide, professional print, or digital image (300 dpi minimum) with 100 words about you and your piece. Include your hometown, the name of the pattern maker, and a list of wood and materials used. Send to Reader Gallery, Scroll Saw Woodworking & Crafts, 1970 Broad Street, East Petersburg, PA 17520, or e-mail [editors@scrollsawer.com](mailto:editors@scrollsawer.com).

# Your Vision. Our Tools.

*"Any tool that makes sanding and finishing this easy and fool proof should be illegal, or at least a sin!"*

Thomas Haapapuro

Bowl by Thomas Haapapuro  
www.thaapdesigns.com

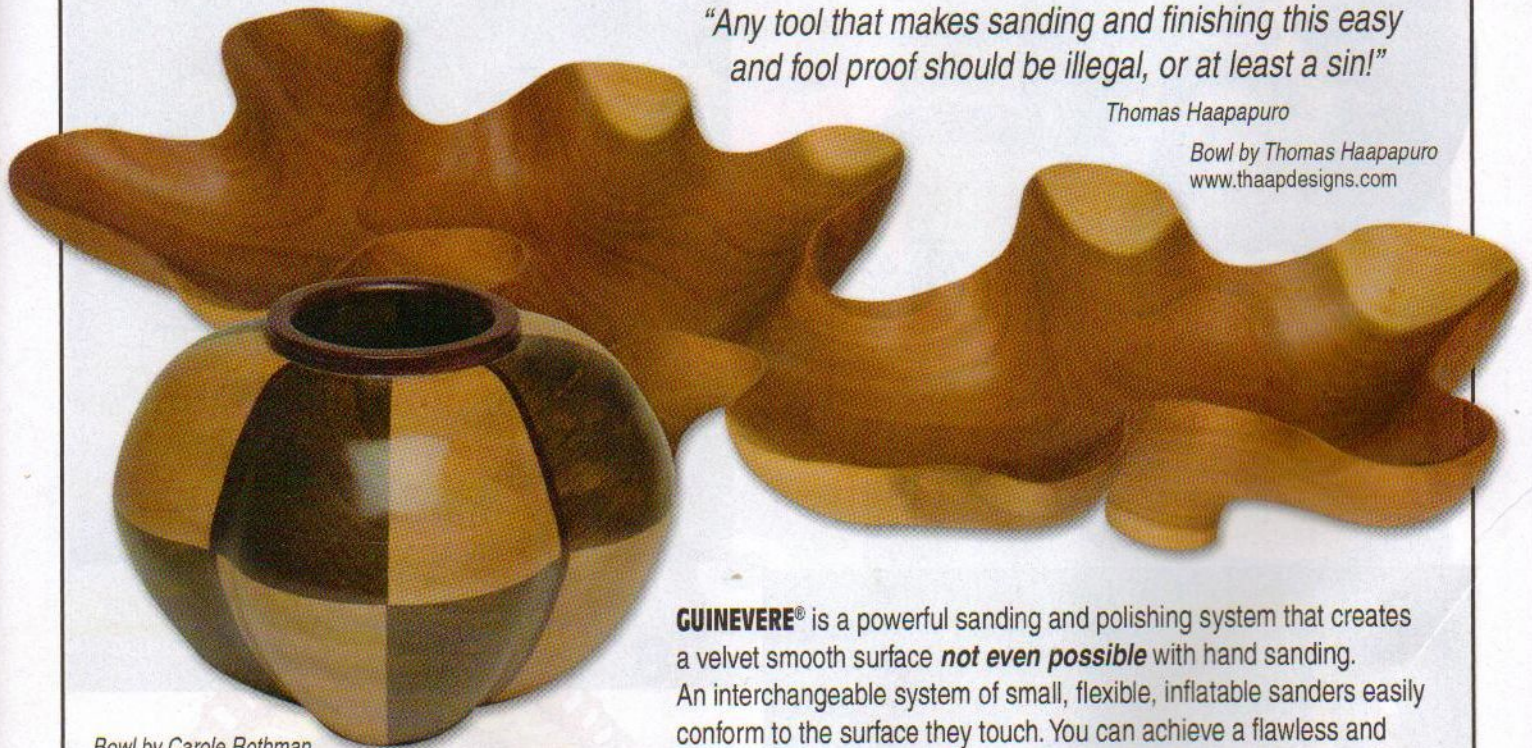

Bowl by Carole Rothman  
www.scrollsawbowls.blogspot.com

**GUINEVERE®** is a powerful sanding and polishing system that creates a velvet smooth surface **not even possible** with hand sanding. An interchangeable system of small, flexible, inflatable sanders easily conform to the surface they touch. You can achieve a flawless and incredibly smooth finish. Experience **your vision** with Guinevere.®



**GUINEVERE®**  
The **FLEXIBLE** Finisher

**GUINEVERE® #11307 TOTAL SYSTEM FOR SANDING INCLUDES:**  
GUINEVERE® 1/2 HP, 110 VOLT, FIXED SPEED 3600 RPM MOTOR WITH 2 STANDARD CHUCKS; 52" FLEXIBLE SHAFT WITH CHUCK, 5 INFLATABLE RUBBER SANDERS; SANDING SLEEVE SETS FOR 5 SANDERS IN 4 GRITS, MICRO HAND PUMP AND CLEANING STICK. CUSTOM MADE IN SWEDEN. MORE ACCESSORIES AVAILABLE.



Tools To Bring Your Vision To Reality

800-942-1300 • [katools.com](http://katools.com)

5



6



7



8



**5. Bonsai** Stephen Bonsib of Little Rock, Ark., created this original design. He cut and carved each 10" tree and inserted it into the opposite piece of wood. He made the frames from padauk and the bases from pink ivory.

**6. Whale** Glenda Richards of Oxnard, Calif., tried intarsia for the first time with this pattern by Judy Gale Roberts. Glenda enlarged the pattern to twice the original size and spent 40 hours making the oak and maple project with the help of her friend Greg Coats.

**7. Wine** Bob Wur of Selkirk, M.B., Canada, made this variation of an intarsia project by Bruce Worthington. Bob combined different SamaN stains to create a variety of shades and hues. He used three shades of red to create the color of the wine. Bob made the project from oak, walnut, aspen, poplar, and cedar.

**8. American Legion** Jim Celius of Cookeville, Tenn., is a Vietnam veteran. He cut this project for his Legion Post, where it is displayed at the front entrance.

# HAWK

Since 1929  
Still made in the USA

Precision Scroll Saws

## Accessories & Gift Ideas



Mini chuck & drill bits



Abrasive cord for precision sanding



Footswitch



Bishop Clamp System



Accessory table



Machinist's square



Mag light



Drip tank



Chair legs

**Call in or  
shop online**

### Bushton Manufacturing, LLC

P.O. Box 127, 319 S Main St. Bushton, KS 67427  
620-562-3557 [www.hawkwoodworkingtools.com](http://www.hawkwoodworkingtools.com)

## Coyote Stencil Shop software

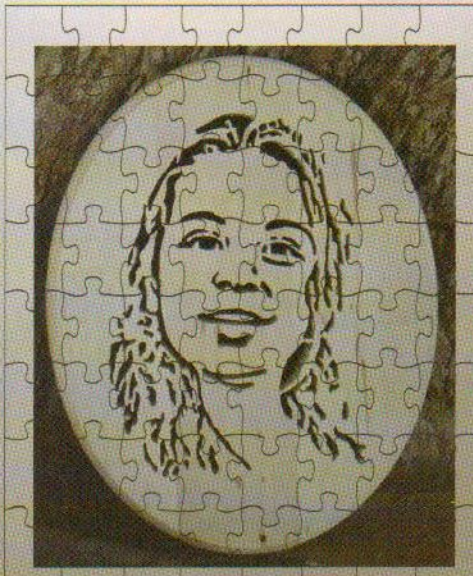

Coyote Stencil Shop comes with a  
**Puzzle Overlay**

- Click to add it
- Position it
- Resize with one-click
- Erase off the excess



**\*Sale Ends Dec. 31, 2016**

**Sale price\***

**\$89.95**  
includes S/H

PC Compatible  
Windows XP Pro - Windows 10

*"Create a Pattern  
from any  
Picture or Photograph"*

*It's easy to use.  
You can do this!*



**CARVING**  
TECHNOLOGIES

*"Linking Images with Imagination"*

PO Box 19053, Lenexa, KS 66285

913 708 8083

[www.carvingtechnologies.com](http://www.carvingtechnologies.com)

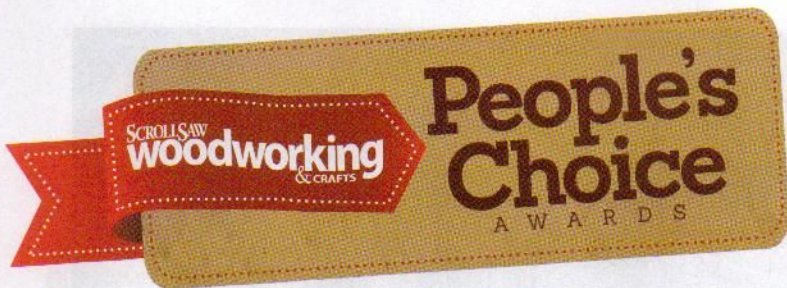

# FUNCTIONAL

## Contest Winners

Meet the winners of the fourth and final 2016 People's Choice Contest

**C**ongratulations to the winners of the fourth 2016 People's Choice Contest!

The category for this contest was Functional. Although there were few entries submitted, we were impressed with the creativity of the projects we received.

We are taking an indefinite break from contests. Thank you to all of those who participated in a contest—we enjoyed seeing what all of you can do. Keep up the good work!

### First Place: Modern Ascension Box

Thomas Haapapuro of Charlotte, N.C., created this box as part of a series he created for his book *Fresh Designs for Woodworking*. The concept was to create unique, organic boxes for the home and office using a scroll saw and power carving tools. This particular box riffs on forms and shapes popular in the mod period of design from the '40s and '50s. The form is repeated vertically to give a striking visual interest, as the box appears to grow from the base much like a blooming plant.

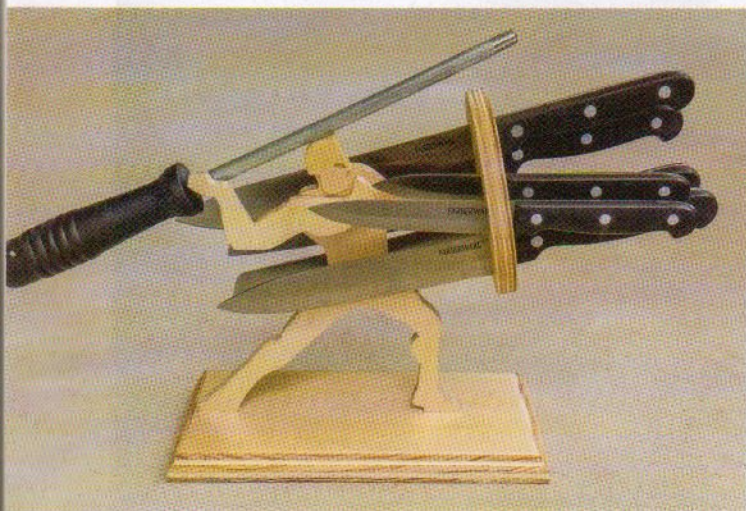

### Second Place: Spartan

Cody Blevins of Aliso Viejo, Calif., was inspired by the movie *300* to create this knife stand. The stand is 6" by 8" by 10" and was made from birch plywood. It was finished with Bulls Eye shellac and can hold up to eight knives.



Superior Quality. Affordable Efficiency.

- 1-3/4 HP TEFC 110V/15A Drive Motor.
- Indexed alignment setting for flawless wide sanding.
- INTELLISAND Technology.
- Easy height adjustment with thrust bearing prevents backlash, slop or creep.
- Drum never goes out of alignment to base.
- Sand as thin as 1/32", as thick as 4", as short as 2-1/4".



Fast Lever makes it easy to change alignment settings for narrow and wide stock.



Easiest access to abrasive fastening system of any drum sander!



25-50 DRUM SANDER



19-38 DRUM SANDER

Please visit SuperMaxTools.com for full specs and distributor locations.

SANDING SIMPLIFIED.

P. 888.454.3401  
F. 651.454.3465

SuperMaxTools.com  
sales@SuperMaxTools.com



Pégas®  
Genuine  
Swiss Quality  
Scroll Saw Blades

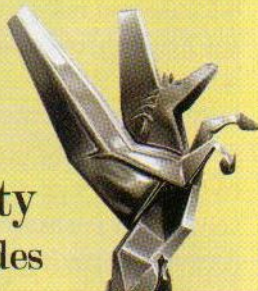

Free Shipping  
on Scroll Saw Blades  
with wood order

www.dndsawbladesonline.com

40 Species of Exotic & Domestic Hardwoods

From 1/16" TO 1-1/2" Thick

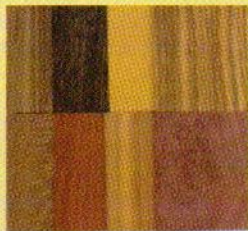

View woods at [www.dndhardwoodsonline.com](http://www.dndhardwoodsonline.com).

12 Species of Plywood. View plywood at [www.dndplywoodonline.com](http://www.dndplywoodonline.com)

FOR PRICE LIST CALL: TOLL FREE: 1-888-751-1400 OR 610-381-2286

FAX: 610-381-5155



D & D Woodcrafts

654 Blue Ridge, Saylorsburg, PA 18353-8138

Work all day on your scroll saw with minimal dust accumulation.

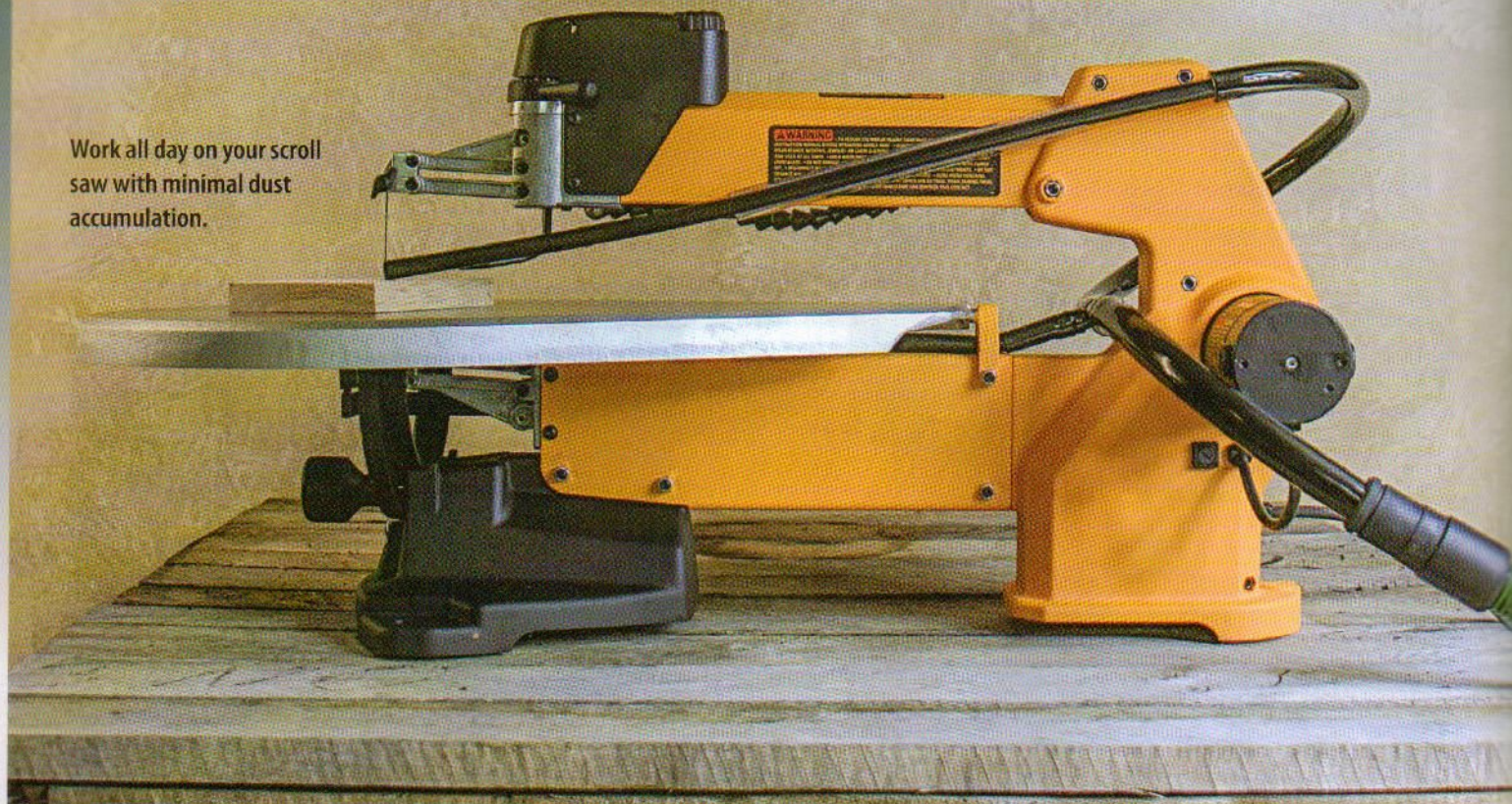

## Scrollnado SCROLL SAW DUST COLLECTOR

The Scrollnado allows you to collect dust above and below the table on the DeWalt 788 and similar scroll saws. The collection of tubes that hooks into a standard shop vac easily captures 95 percent of the dust produced by a scroll saw. The Scrollnado is the ultimate scroll saw dust collector.

Unfortunately, at this time the unit only fits saws similar to the DeWalt 788 (such as the Delta 40-690, Delta 40-694, and Delta 40-695), but the inventor is working to adapt it to other saws. The top tube, which catches the majority of the dust, can be used on most saws. But the bottom tube that the scroll saw blade passes through requires the blade guide under the table of the DeWalt 788 (and similar saws).

No tools are required to install the Scrollnado on a saw; you only need to take the saw table off to install the tube under the table. The lower tube does not effect scrollers who feed the blade up from the bottom of the blank, but it does require scrollers who

feed from the top down to relearn the process, because you need to feed the blade through another hole on its way to the bottom blade clamp.

The top tube attaches to the upper saw arm using a magnet. It's easy to adjust so you can position it close to the blade and also keep it from interfering with your cutting.

With both tubes in use, even after a day of cutting, there was little dust under the saw table. Normally I'd be dusting off my pants each time I stood up, but there was no visible dust on my pants when I was using the Scrollnado.

The Scrollnado can be adapted to fit most shop vacs, but most shop vacs are loud and not intended for use over long periods of time. Using a series of adapters, you can hook the Scrollnado into a standard dust collector. Another option is to look into quiet portable dust collection units, such as those by Festool or Foredom. These dust collection units are more expensive, but they will withstand long periods of use and are much easier on your ears.

*The Scrollnado is available for \$49.95. Order from the inventor through [www.amazon.com](http://www.amazon.com).*

**“The Scrollnado is the ultimate scroll saw dust collector.”**

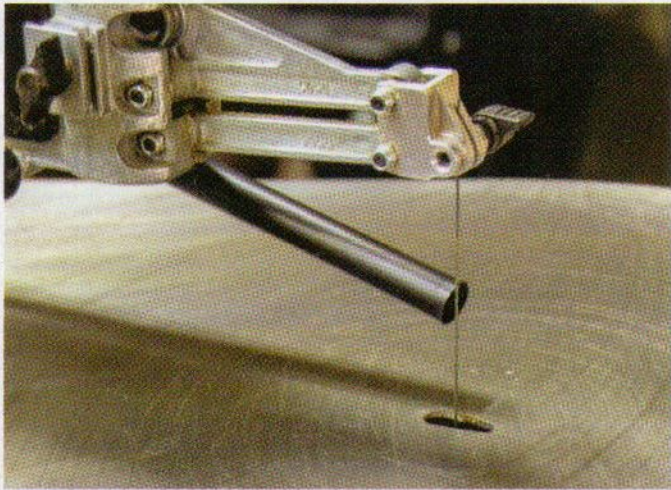

The upper collection hose captures dust from the top of the project, instead of blowing it away.

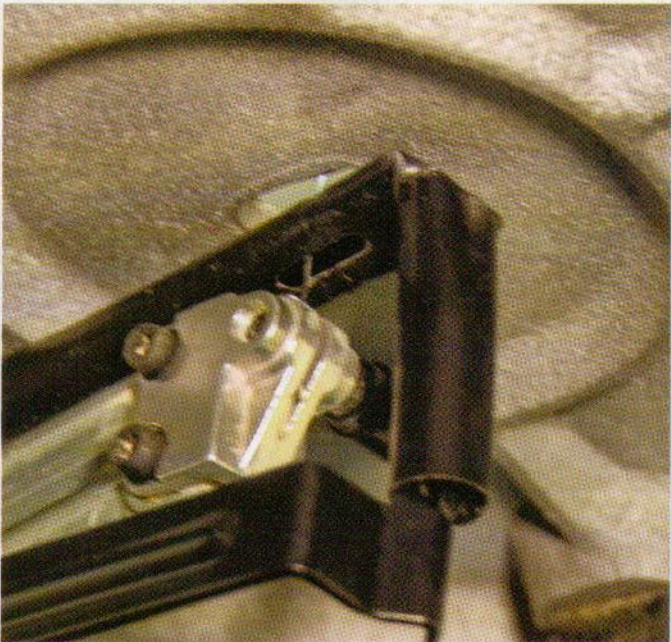

The lower collection hose mounts directly below the cutting area, and the blade actually passes through it.



The flexible vacuum nozzle and magnetic mount let you position the dust collector where you need it.

## SUPER SHARPS™ scroll saw blades

### \*Improve your saw's performance

PS Wood offers scroll saw blades that cut faster, easier, and will not burn the wood!

### \*Exclusive tooth-and-gullet design

Once you try these extraordinary scroll saw blades, you'll be "hooked" forever! Experience smooth, trouble-free cutting through even the thickest of hardwoods, and you'll see why these blades are supreme!

**\*No drifting** - We set our teeth both ways, and insert a raker tooth to ensure perfect tracking and clean cuts every time.

**NEW \*Metal cutting** (2/0M, 2M, 6M) - for cutting ferrous & non-ferrous metals, precious metals and non-metallic materials



Blade #	Width	Thickness	TPI	Use	Price/dz	Price/100
2	.029"	.012"	20	1/4" or less	\$9.95	\$65.00
5	.038"	.016"	12.5	3/4" softwood	\$9.95	\$65.00
7	.045"	.017"	11.5	3/4" to 1 1/2" hardwood	\$9.95	\$65.00
9	.053"	.018"	11.5	1 1/2" to 2 1/2" hardwood	\$9.95	\$65.00
12	.062"	.024"	9.5	straight-line cutting	\$9.95	\$65.00
NEW 2/0M	.022"	.010"	61	up to 1/16" wood & metal	\$9.95	\$65.00
NEW 2M	.028"	.013"	30	up to 1/8" wood & metal	\$9.95	\$65.00
NEW 6M	.039"	.020"	20	up to 3/16" wood & metal	\$9.95	\$65.00

### SUPER SHARPS Variety Packs

257 Variety Pack includes 1/2 dz #2, 1/2 dz #5, 12 dz #7.....\$14.95  
579 Variety Pack includes 1/2 dz #5, 1/2 dz #7, 1/2 dz #9.....\$14.95

**PS Wood Machines** 3832 Industrial Blvd., Bethel Park, PA 15102  
**1-800-939-4414** [www.pswood.com](http://www.pswood.com)



You can do the most intricate **Inlay** that you desire.

## YOU CAN DO THIS!



Enhance your **Scroll Saw** and **Turning** projects.



Hard Steel is no problem!



**Gunstocks** are fun and easy—Fish Scale, Basket Weave, Leaves, whatever you like.

The all metal Shofu Lab Air-Z **OIL FREE** handpiece is the work horse of high speed air tools. At 36,000 rpm, fine detail work is easy and fast—like a pen on paper. We have been creating beautiful art on **wood, metal, glass, gourds, stone, leather, plastic, and more** since 1998.

You can carve a delicate **Goose Egg** without breaking it.



**MANY PEOPLE EARN AN EXTRA INCOME USING THE SHOFU LAB AIR-Z**

## ORDER OUR FREE DVD

[WWW.GRAPHICTRANSFER.NET](http://WWW.GRAPHICTRANSFER.NET) or call us today 928-453-2652

# Chain Support

**TOP TIP** ✓

## Simple hack lets you support any box lid

By Carole Rothman and Joe Ilardo

**J**ewelry boxes with hinged lids often need some way to keep the lid from falling backward when opened. One solution is to attach a lightweight brass chain which is readily available at craft shops. While the chain can sometimes be screwed directly into the side and lid, this is not always possible, as with boxes constructed from a single unit that was cut apart to separate the box body from the frame and panel lid. We developed a simple chain support consisting of two end pieces connected by a piece of chain that holds the lid securely and still allows it to close without interference.

### Materials & Tools

#### Materials:

- Hardwood,  $\frac{3}{8}$ " (10mm) thick: 2 each,  $\frac{1}{2}$ " x  $1\frac{1}{4}$ " (13mm x 32mm)
- Brass chain for crafts: approx. 7" (178mm) long
- Brass escutcheon pins: 2 each,  $\frac{3}{4}$ " (19mm) long
- Glue: quick-setting PVA

#### Tools:

- Scroll saw blades: #3, #12
- Drill bit: #54 wire size
- Tack hammer
- Wire cutter
- Emery board

*The author used these products for the project. Substitute your choice of brands, tools, and materials as desired.*

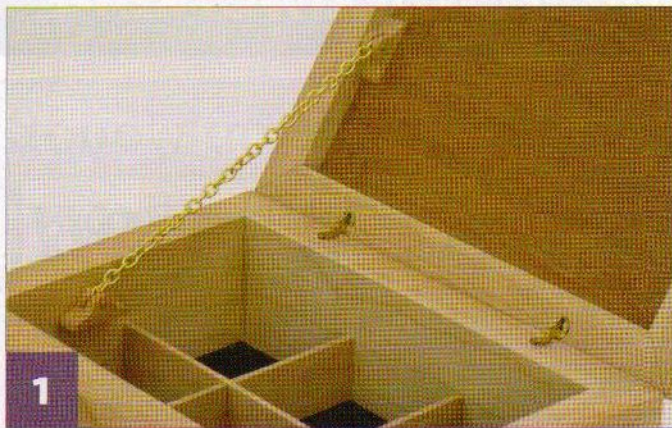

**1 Mark the points of attachment.** The bottom of the chain is attached just forward of the midpoint of the box side, about  $\frac{1}{4}$ " (6mm) down from the top edge. The upper end of the chain is attached to the center of the inside face of the lid frame. Hold the lid in place as you try out different lengths of chain. The chain length determines how far the box lid can open. Mark the link and cut the chain to size.

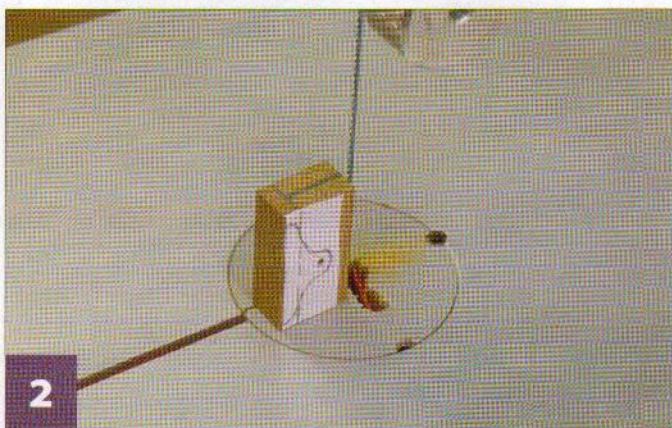

**2 Attach two copies of the pattern to the blanks.** For each blank, drill a through-hole where indicated. Extend the dotted line on the pattern across the side edges and draw a line down the center.

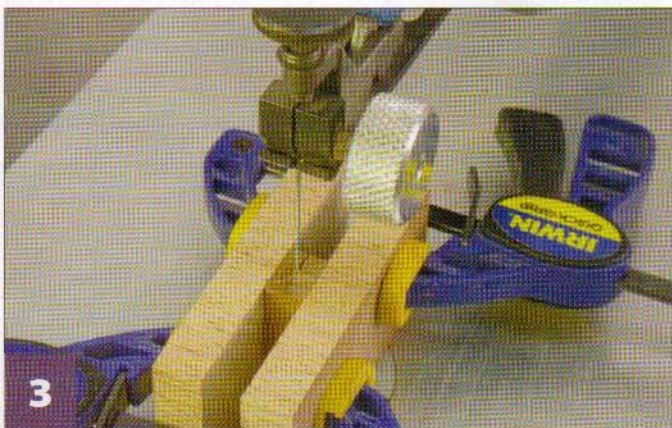

**3 Place the block on its short end.** Position it so the blade will start the cut at the top of the pattern. Secure the block with supports and clamps. Using a #12 blade, cut down the block from the top to the dotted line, cutting just to the left of the centerline. Recut the slot, moving from left to right until it is wide enough for a chain link to fit, about  $\frac{1}{32}$ " (1mm). Cut the profile with a #3 blade and sand the piece smooth, using an emery board for the slot.



**4 Slip each end link into a holder.** Pass an escutcheon pin through the hole to secure the link. Place the holders against the box at the marks made in Step 1 and use a tack hammer to mark where each pin will be driven. Deepen the indentation with a finishing nail or small drill bit. If the pin is too long, snip it to length and re-sharpen the tip with a file. Attach the holders with quick-setting PVA glue, and then drive the escutcheon pins into place. Support the lid until the assembly is fully dry.

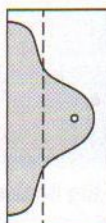

## Chain attachment pattern

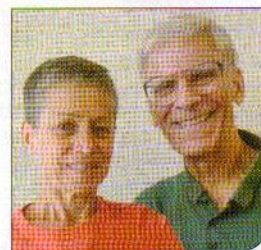

*Carole Rothman and Joe Ilardo are retired college teachers, mental health professionals, and authors. Now enthusiastic woodworkers, they have separate workshops*

*but freely share tools and enjoy collaborating on woodworking projects and instructional videos.*

# Scroll Saw Books for Inspired Woodworking

## Make Magnificent Mechanical Marvels from wood!

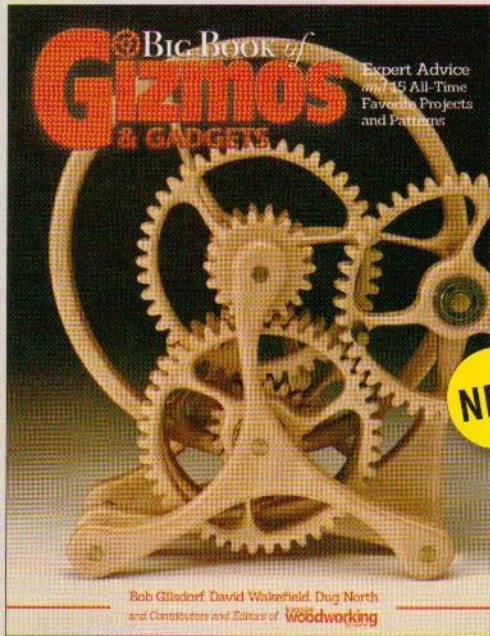

### Big Book of Gizmos & Gadgets

Expert Advice and 15 All-Time Favorite Projects and Patterns

By the editors of *Gizmos and Gadgets*

Start making wildly inspired mechanical marvels from wood with these ingenious plans. Well-illustrated step-by-step projects are arranged by skill level from beginner to advanced. Projects range from a Rapid-Fire Rubber Band Gun and a Kicker Treat Gumball Machine, to whirligigs and classic automatons for cowboys, ballerinas, cats, ships, and more. Create fun games and toys for the whole family, and discover the secrets of kinetic sculpture to build your own interactive wooden gear machine.

Includes full size pattern pack  
\$16.99 • Code: 9012B

**NEW**

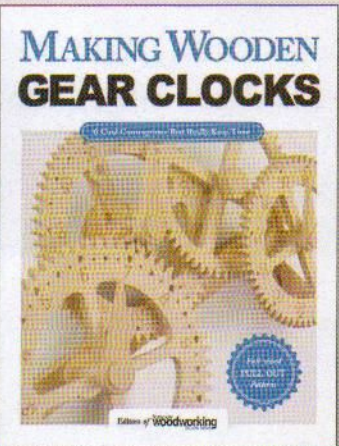

### Making Wooden Gear Clocks

6 Cool Contraptions That Really Keep Time  
By the editors of *Scroll Saw Woodworking & Crafts* magazine

Inside this book you'll find ingenious plans for creating 7 awesome wooden machines that actually move and keep time, with step-by-step projects arranged by skill level.

Includes full size pattern pack  
\$14.99 • Code: 8893M

**Order both *Big Book of Gizmos & Gadgets* and *Making Wooden Gear Clocks*—SAVE 15%!**

**List price: \$31.98 • YOUR PRICE \$27.00**

(Discount applied automatically at checkout)

## Everyone loves a great PUZZLE

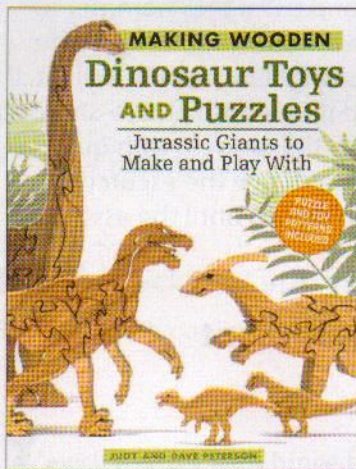

### Making Wooden Dinosaur Toys and Puzzles

Jurassic Giants to Make and Play With

By Judy and Dave Peterson

Create 38 exciting wooden dinosaur puzzles and toys to delight a special child in your life with this ingenious book. Patterns are also provided for easy-to-cut dinosaur toys that are safe for little kids who can't play with small objects.

\$19.99 • Code: 8909M

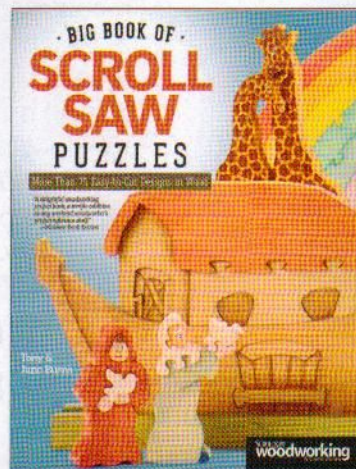

### Big Book of Scroll Saw Puzzles

More Than 75 Easy-to-Cut Designs in Wood

By Tony & June Burns

Make beautiful freestanding art puzzles on your scroll saw, with 75 shop-tested and ready-to-use patterns, plus step-by-step instructions for cutting, staining, and painting.

\$19.99 • Code: 8596

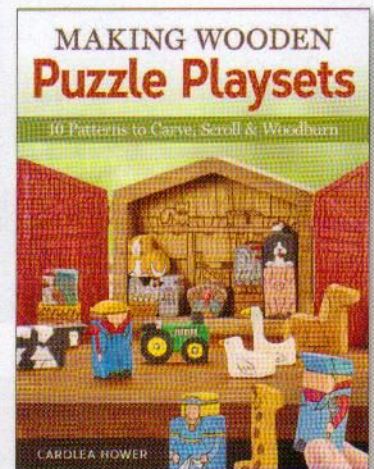

### Making Wooden Puzzle Playsets

10 Patterns to Carve, Scroll & Woodburn

By Carolea Hower

Combine a clever puzzle and a fun playset in one handy self-contained carrying case, with 11 imaginative projects that are sure to captivate and delight everyone who sees them.

\$16.99 • Code: 8664

**Order all three puzzle books above and SAVE 15%! — List price: \$56.97 • YOUR PRICE \$48.00**

(Discount applied automatically at checkout)

**ORDER TODAY! 800-457-9112 • www.FoxChapelPublishing.com**

**FREE SHIPPING on all orders!\***

Scroll something WILD this weekend

## WOODWORKER'S Pattern Book

78 Realistic  
Fretwork Animals

Wayne and Jacob Fowler



### Woodworker's Pattern Book

75 Realistic Fretwork Animals

By Wayne and Jacob Fowler

Use your scroll saw to create realistic wooden animal portraits, from exotic predators to familiar backyard friends. Father and son scroll sawing team Wayne and Jacob Fowler base their patterns on their own extensive photographic studies of live animals, taken on location in the wild, in zoos, and in nature preserves. From jaguars and jackrabbits to rattlesnakes and rhinoceros, each animal can be cut as a single, freestanding piece of wood. A beautiful full color photo gallery will inspire you to make a wide range of impressive wildlife projects.

\$16.99 • Code: 9029

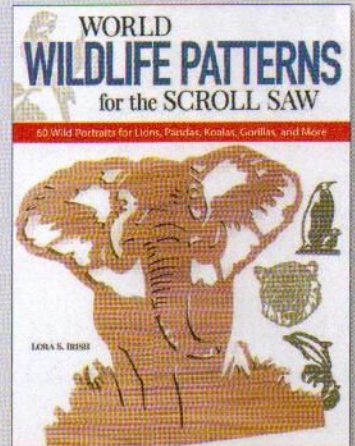
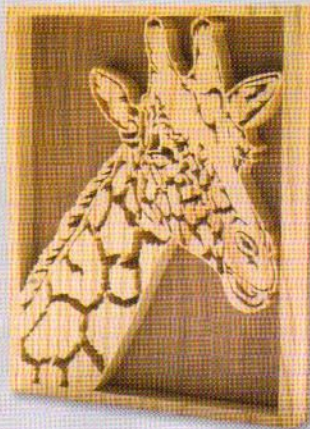

### World Wildlife Patterns for the Scroll Saw

60 Wild Portraits for Lions,  
Pandas, Koalas, Gorillas, and More

By Lora S. Irish

Scroll exotic wild animals from each of the seven continents, with patterns for all of the world's best-known species, from antelopes to zebras.

\$12.95 • Code: 1775

Order both *Woodworker's Pattern Book* and *World Wildlife Patterns for the Scroll Saw*—**SAVE 15%!**

List price: \$29.94 • **YOUR PRICE \$25.00**

(Discount applied automatically at checkout)

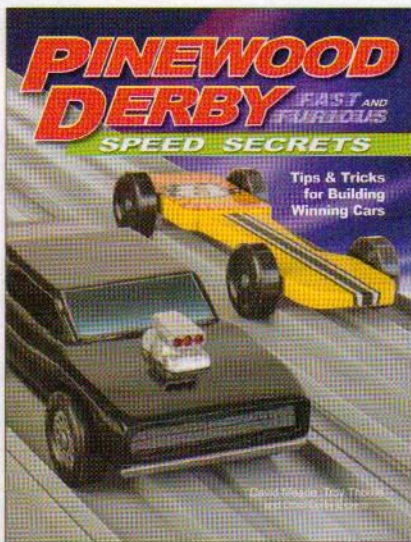

## Build the Fastest Car in the PINewood DERBY®

### Pinewood Derby Fast & Furious Speed Secrets

Tips & Tricks for Building Winning Cars

By David Meade, Troy Thorne, Jon Deck, and Other Derby Experts

Create a sensational racer while building memories that last a lifetime. In this ultimate guide to Pinewood Derby success, derby-winning dads share their tips, techniques, and amazing patterns so that parents and scouts of any skill level can work together to make an awesome, lightning-fast car. This easy-to-use guidebook provides 19 phenomenal designs and inventive ideas for crafting exciting and eye-catching Pinewood Derby cars. You'll learn how to produce the coolest car ever, with original patterns and step-by-step instructions for building a "Diesel" Dodge Charger or a VW Beetle Race Car.

96 pages • Code: 9043 • \$12.99



### 100% SATISFACTION GUARANTEE

If, for any reason, at any time, you are less than satisfied with any Fox Chapel Publishing product, simply return it and we will gladly exchange it or refund the full purchase amount, whichever you prefer.

#### Three Ways to Order:

1. Call toll-free 1-800-457-9112
2. Order online at [www.FoxChapelPublishing.com](http://www.FoxChapelPublishing.com)
3. By mail. Send check or money-order to:  
Fox Chapel Publishing  
1970 Broad Street  
East Petersburg, PA 17520  
Please allow 7-10 business days for order delivery



#### \* FREE SHIPPING with your order!

Regular shipping and handling is FREE for all orders shipped within the USA. Use coupon code SSW66 after placing item in cart or when ordering. Offer expires 4/30/17. For orders shipped outside the USA you will receive a discount equal to the US shipping cost and we will bill you the difference.

  
**FOX CHAPEL**  
PUBLISHING

# Creative Projects

## FROM COLORING BOOKS

**The coloring fad has a side benefit: the designs are great for woodworking, too!**

By Mindy Kinsey

**W**e've all heard the buzz: adults are reclaiming their inner kid by coloring. Thousands of coloring books designed for adults have been released in the past two years, and rumor has it the fad has created a shortage of colored pencils. But even if you're not interested in applying color to page, the books are still valuable: you can use them for woodworking patterns!

We shared samples with a half-dozen woodworkers to see what they would come up with. (Full disclosure: Fox Chapel Publishing, this magazine's parent company, publishes coloring books, so we used our own.)

On the scrolling side, many designs are natural for intarsia, although some simplification may be required. We also had good luck using Color Your Own Stickers to make jewelry. Transforming coloring pages into fretwork patterns is a little more challenging, although two of our test cutters, Dale Helgerson and Bob Duncan, were able to make frames by being selective in their cuts. A few of our books included inspirational sayings that we were able to cut as word art.

For carvers and pyrographers, coloring books are a treasure trove. Many of the designs are perfect for relief and chip carving, as well as woodburning. Creating in-the-round carvings from coloring pages would be more challenging, but with a little imagination, you can sketch the unseen views and make patterns.

We hope our projects will inspire you to take a second look at coloring books. Make a few photocopies, sketch some ideas, and get scrolling! We have included a couple of these patterns on our pullout to get you started and posted a few more on our website. If you try it, send photos! Be sure to tell us which coloring book you used (doesn't have to be ours—pick something that inspires you) and how you adapted the design to make your project.





dream

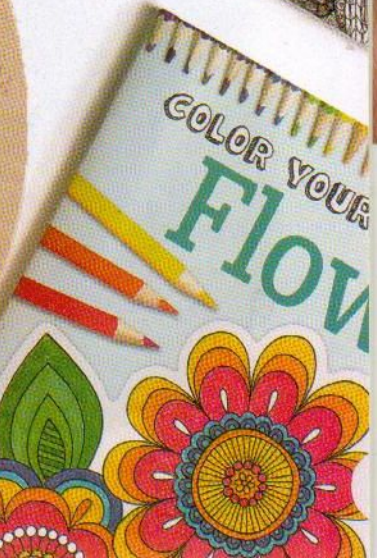
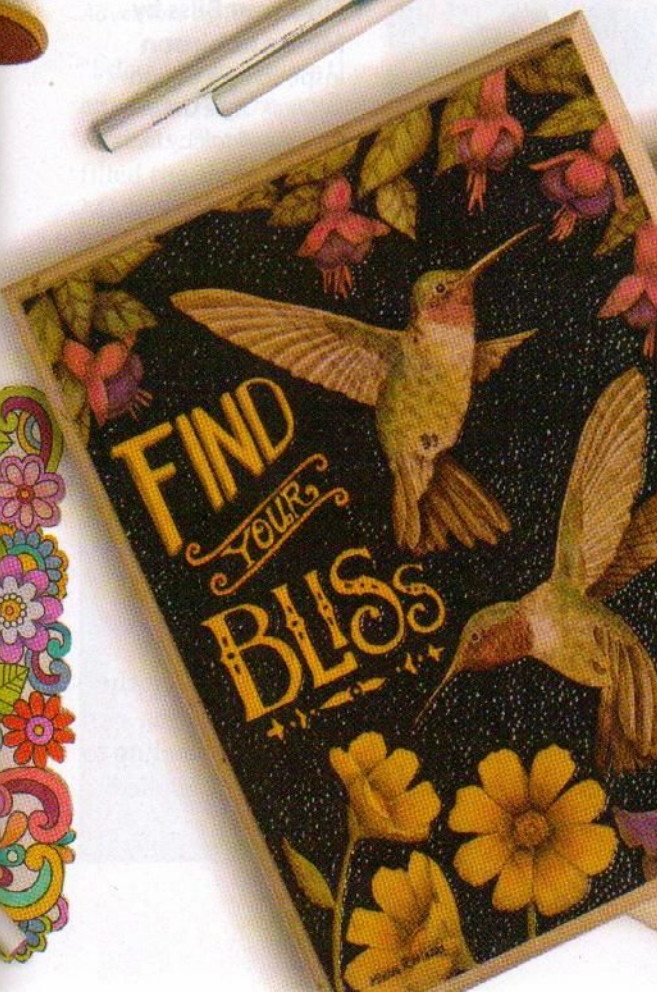
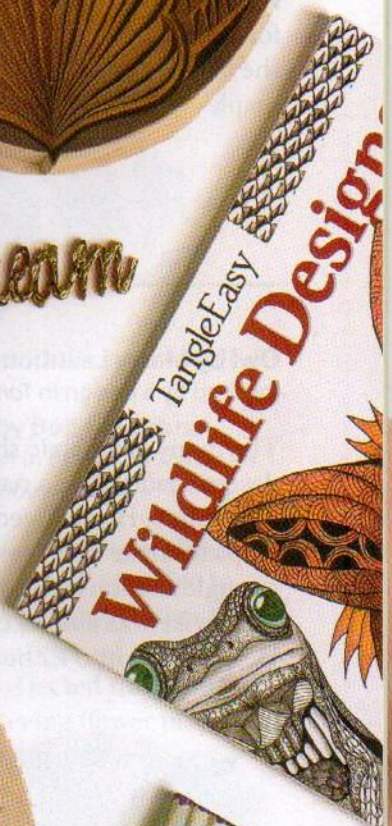

### Dragonfly by Rolf Beuttenmuller

Inspired by a design in *TangleEasy Wildlife Designs* by Ben Kwok, as colored by Marie Browning, CZT

"The idea for using the coloring books for intarsia inspiration is a great one!" said Rolf Beuttenmuller. We usually turn to Rolf as a test cutter for mechanical projects, but we know he enjoys intarsia, too. For this project, he chose a TangleEasy design that has large segments, and then slightly simplified it; for example, he cut the body in one piece and sanded the segments. Rolf used iron wood for the body, red heart and yellow heart for the wings, wenge for the eyes, and walnut for the legs; the backer is maple.

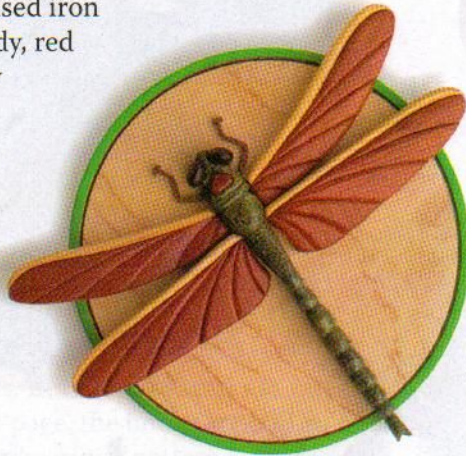

### Frame by Dale Helgerson

Inspired by a design in *Creative Coloring Inspirations* by Valentina Harper

To make a fretwork frame, Dale Helgerson reduced his chosen coloring page to suit a 5" by 7" photo and then selectively traced and adapted the design. He used veining lines to add the details, and noted that he would use a larger blade to make those lines stand out more if he cut it again.

The design Dale chose included an inspirational quotation. He cut the words, intending them to be glued to the frame, but we are showing them separately. They could be enlarged to create freestanding word art or used as ornaments or other decorations.

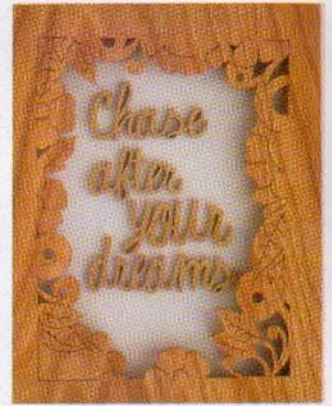

### Owl by Marty Leenhouts

Inspired by a design in *TangleEasy Birds* by Ben Kwok

The many geometric shapes in a TangleEasy design made them a natural for chip carver Marty Leenhouts. He changed the sizes of some of the chips to make them easier to carve and changed a tangle section into more traditional chips, but otherwise was able to carve the design as drawn. He carved it into EZboard, which is a high-density urethane that doesn't have grain and holds detail well, so it's ideal for chip carving. To hide the natural green color of the EZboard, Marty painted the design with acrylics and an airbrush.

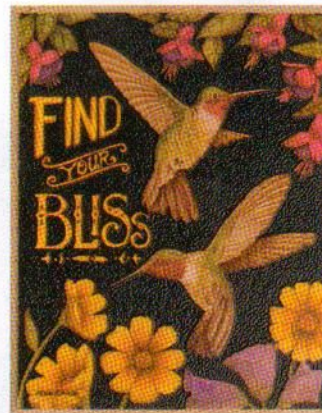

### Find Your Bliss by Minisa Robinson

Inspired by a design in *Chalk-Style Garden Coloring Book* by Deb Strain

Minisa Robinson is known for creating deep black backgrounds for her woodburned designs, so it seemed natural to ask her to tackle a chalk-style design. Meant to emulate chalkboard artwork, these coloring books come prefilled with dark backgrounds. About her approach to the project, Minisa said, "First I used graphite paper to transfer the image onto the wood, and then I used a small woodburning point to outline the design. Next, I used a larger point to black out the background using a stippling effect. A shading point worked well to add the details and shading to the flowers and hummingbirds. Finally, I applied acrylic paint for the color."

## Jewelry by Fox Chapel Staff

Made using stickers from three books in the *Color Your Own Stickers* series: *Frames and Borders* by Valentina Harper and *Flowers* by Jess Volinski.

The minute we saw the *Color Your Own Stickers* books, we knew the designs would be perfect for making jewelry. We chose small designs that could be worn as pendants or earrings, colored them using markers and colored pencils, and adhered them to 1/8"-thick Baltic birch plywood. We sprayed the boards with clear finish to protect the coloring and then cut around the designs. Our test cutter, Bob Duncan, notes that you should not use reverse-tooth blades with stickers because they will pull the paper off the wood. Finally, we added beads and jewelry findings to our colorful artwork to create trendy and attractive earrings, necklaces, and a wrist wrap. We think larger flowers, snowflakes, and mandalas would make great Christmas ornaments.

We also colored and cut a frame sticker, which we're showing here without a photo. We will probably use it as a mat in a frame, but it would also be easy to add a backing board for a freestanding project. The technique could also be used to turn any colored page into a plaque simply by gluing the art to the wood and cutting the perimeter.



## Bouquet by Michele Parsons

Inspired by a design in *Seek Color Find Nature: A Treasure Hunt and Coloring Adventure* by Robin Pickens

"I decided to render the coloring book art in a graphic style, emphasizing the outlines of the shapes," said pyrographer Michele Parsons. She traced the pattern lines with a skew tip and then filled the shapes using a shader. In keeping with the graphic style, Michele used mainly flat tones, although she was careful to include a wide range of them both on the overall picture and for each shape within an area. For example, the flower stems and leaves are all dark but there are variations of dark tones within this area. She

softened the effect with light graduated shading on the petals and ribbon.

To create a personalized gift, Michele added text to the design. She typed and sized the text on a computer, printed it, and transferred it to the wood. She traced and filled the text, and then carefully outlined the larger letters with a skew to create clean, sharp edges.



## Christmas Bells by Bob Biermann

Inspired by a design in *Christmas Traditions Coloring Book* by Robin Pickens

A relief carver who enjoys painting his work, Bob Biermann was able to follow his chosen coloring design fairly closely. He left out a few of the details, but noted that it affected the painting more than the carving (fewer places to put color). He chose to leave off some lettering included in the original design.

Some patterns for **CREATIVE PROJECTS FROM COLORING BOOKS** are in the pullout section.

**ON THE WEB** Additional patterns are available for download.  
[www.scrollsawer.com](http://www.scrollsawer.com)



# Creative Cuts

## Three-dimensional scroll saw art with a twist by David Hobbs

By Kathleen Ryan

David Hobbs creates three-dimensional wall hangings that include such zany subjects as a lounging mouse smoking a pipe, an octopus perusing a pile of books, and a two-headed bird perched on a skull. "I'm inspired by things I see in everyday life, such as animals. Then I twist them into something more interesting," said David. "I like to place my subjects in impossible situations they could never get themselves into in real life."

Art lassoed David's heart as a young child, but it wasn't until after high school that he gave it free reign. "I loved to draw all through school, but I didn't care so much for art when someone else was telling me how and what to create. I didn't realize my true passion until I began painting strictly for myself," said the Loveland, Colo., native. David became inspired by the work of the American abstract artist Jackson Pollock and the street artist Kenor. "The colors and shapes of abstract art are what really hooked me," he said. "Being red/green color blind, I loved the fact that abstract art allowed me the freedom to use tons of different color combinations."

Over time David's work became less abstract and more representational. "I felt like I was painting myself into a rut because a lot of my work began to look similar, so I started making creatures out of shapes," he explained. The three-dimensional aspect of his art happened quite unexpectedly. "One day I took an X-acto knife to a drawing I had done on Masonite board. I whittled away at it for about 10 hours until it became a cutout. After I painted it, I knew I would never go back to painting on canvas again!" David borrowed his father's Craftsman scroll saw and never looked back.

**King Coon and His Watch Bird**, 8" by 10", is a mounted cutout on Masonite and was made with acrylic and India ink.





**Ice Cream Screams**, 6" by 15", is a mounted cutout on Masonite and was made with acrylic and India ink.

Today David creates in his home studio surrounded by art books, magazines, and supplies. With a subject in mind, he sketches his thoughts on paper and then uses graphite paper to transfer it onto a Masonite board. He cuts out the image with his Porter Cable scroll saw using mainly #7 skip-tooth and #5 reverse-tooth blades. "I love that the scroll saw brings life to every piece and movement you make, while cutting adds character," he said.

After sanding, David paints his cutouts with regular flat house paint. "I started with tube paint, but it got too expensive to collect all the colors I wanted," he said. Then it occurred to him that house paint is acrylic paint, too. "It's less expensive than tube paint and has a similar dry time. It takes a little getting used to because it's much thinner than tube paint." David started buying quart cans of house paint at thrift stores. He soon realized that a quart was too much paint and began buying seven-ounce "oops paint" samples from home stores. "This allows me to have a massive selection of colors at a really low price."

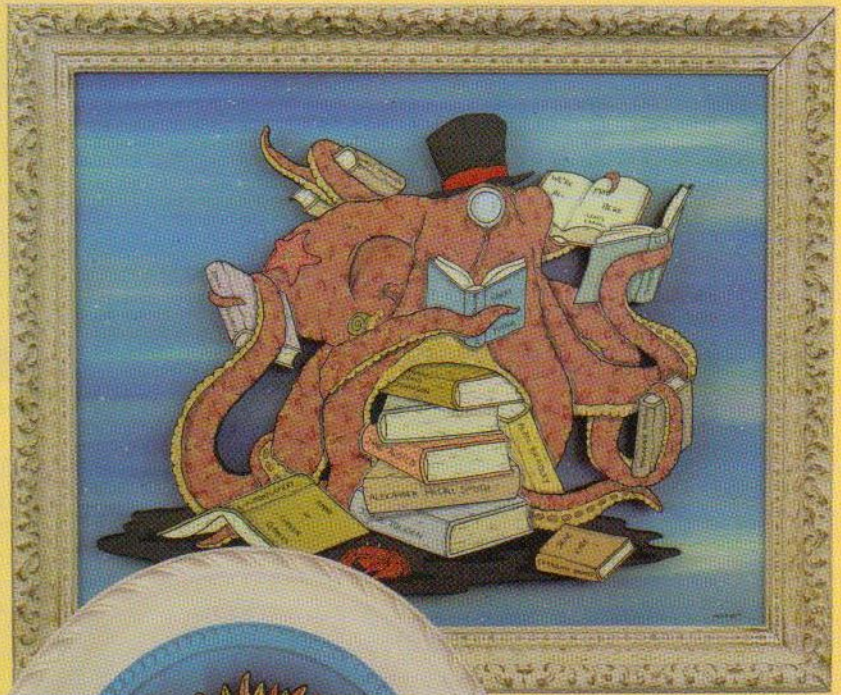

**The Octopus**, 16" by 20", is a mounted cutout on Masonite and was made with acrylic and India ink.



**Translucent Beauty**, 6" by 9", is a mounted cutout on Masonite and was made with acrylic and India ink.

David applies the paint with small artist brushes. Once it dries, he adds details with a calligraphy pen. "Some artists outline with pens like Sharpies, but that leaves such a flat look. Ink has a texture and distinct look that I have not found using anything else. And, as much as it is a pain to be constantly dipping and cleaning pen nibs, I absolutely love it." The finished artwork is mounted on a Masonite background and set in frames that David finds at thrift stores and refinishes himself.

The 28-year-old said he plans to continue growing as an artist and sees a bright future ahead. "As long as I am still creating and loving every minute of it, I would say my art is a success."

Contact David at [davidhobbsart@gmail.com](mailto:davidhobbsart@gmail.com).

# Spring Gathering

## Complex intarsia features a variety of beautiful birds

Project, photographs, and article by Janette Square  
Design by Bruce Worthington

This intarsia makes a beautiful reminder of some of the lovely birds we see in spring and throughout the year. Whether or not these birds visit your neck of the woods, on those dreary winter days it's nice to be able to look at and enjoy these wooden ones, which will hopefully tide you over until the real ones arrive. This is a challenging piece to make but rewarding once completed. Whether for yourself, a gift, or to sell, you will feel a tremendous sense of accomplishment.

### Getting Started

Because of the size and scope of this project, start by getting organized and deciding on your plan of attack. I began by assigning each bird a letter and numbering them individually (A1, A2, A3, etc., for the female cardinal and B1, B2, B3, etc., for the male cardinal). I labeled the leaves with an L and did the same, also noting dark and light shades. The birch trees were made with four different shades, and each piece was labeled LT, M, MD, or D with a corresponding number. This is essential in keeping track of the pieces, as it's easy to become overwhelmed. Breaking the pattern down into individual elements and then working on them one at a time can help keep things manageable. This applies from wood selection all the way to shaping and assembly.

When making a framed intarsia, I've learned to make the frame first and then cut the pieces to fit the frame. Select a complementary colored wood and complete a frame in the style of your choice. The inside dimensions should be 17" by 23" (432mm by 584mm). Using a router or table saw, cut a  $\frac{1}{8}$ " (3mm)-deep by  $\frac{1}{4}$ " (6mm)-wide groove in the back of the frame pieces. This will accommodate the backer when the piece is done. *Note: If your backer is a different thickness, adjust the depth of the groove.*

## BIRDS: CUTTING THE PIECES



**1** **Select the wood for each piece.** Apply clear packaging tape to the wood and attach the pattern with spray adhesive. Cut the individual pieces. Focus on one area at a time, and then move on to the other birds, trees, and leaves. Remove the pattern from each piece, transfer the pattern number to the bottom of each piece, and dry-assemble the pieces on a copy of the pattern.



**2** **Assemble the tree trunks.** Use the photo above to see which trunk sections are shaped as one piece. Then, glue the individual pieces in those sections together.



**3** **Dry-assemble all of the pieces inside the frame.** Trim the edge pieces to fit if needed and adjust any other pieces to fit the frame. Pieces will have a tendency to shift, especially with this type of project that has open areas. Then, drill  $\frac{3}{16}$ " (5mm)-diameter eyeholes for all of the birds.



## BIRDS: SHAPING & STAINING THE PIECES

It's easier to break the project into sections for shaping. I start with the tree pieces. Work on the thinnest areas first and progress to the thickest parts. Once you are satisfied with the overall appearance of the trees, move on to the birds and leaves. When shaping each piece, always keep in mind the surrounding pieces. Use a pencil to mark where an adjoining piece lands to use as a guide.

### TIP

#### ADDING DEPTH

*When a leaf is completely surrounded by other pieces you can add a riser made from scrap  $\frac{1}{8}$ " (3mm)- or  $\frac{1}{4}$ " (6mm)-thick plywood to bring the leaf higher. This adds more depth to the project.*

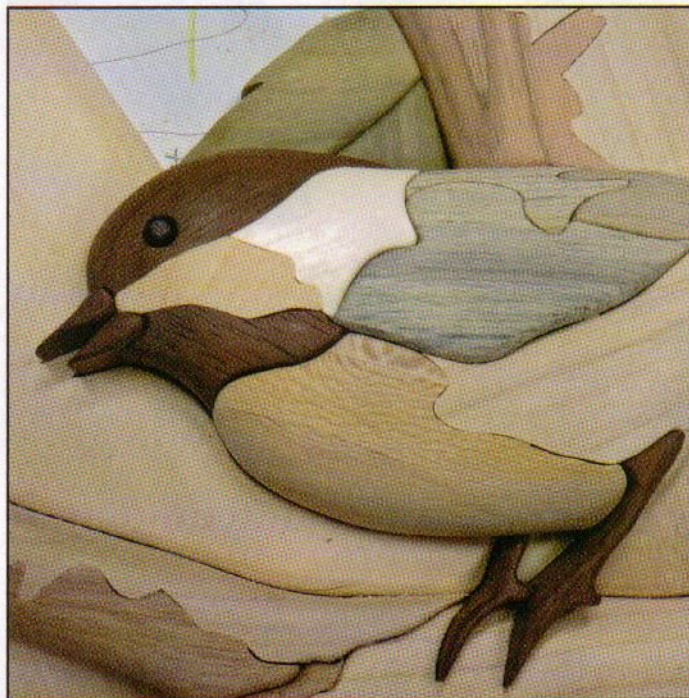

4

**Shape the pieces.** I've included some close-up reference photos to use as guides as you shape. Start with a 120-grit flexible drum sander. Smooth the pieces with a 220-grit flexible drum sander. Sand with the grain to eliminate any scratches from the coarser drum. Hand-sand the edges of each piece with 220-grit sandpaper and a sanding sponge. Then, buff each piece lightly with a 180- to 220-grit mop sander.

## BIRDS: GLUING & FINISHING THE PROJECT

Gluing a project like this can be a challenge. Because pieces tend to shift more with the open spaces, I found that gluing together individual sections of the project first to make fewer larger pieces works best. With the project dry-assembled, glue just the individual birds together, returning them to their positions until dry. Glue the leaf pieces together so you have completed leaves, and then glue the segments of the trees where the branches extend. You should end up with about six tree sections, the individual birds, and some leaves. Apply a finish of your choice to these sections following manufacturer's directions. Be careful not to get finish on the backs or sides of the gluing surfaces.



**5** **Stain the bluebird pieces.** I use Minwax Express Color Indigo wiping stain. Wipe off the excess. Repeat until you get the color you want, and then lightly buff again with a mop sander.

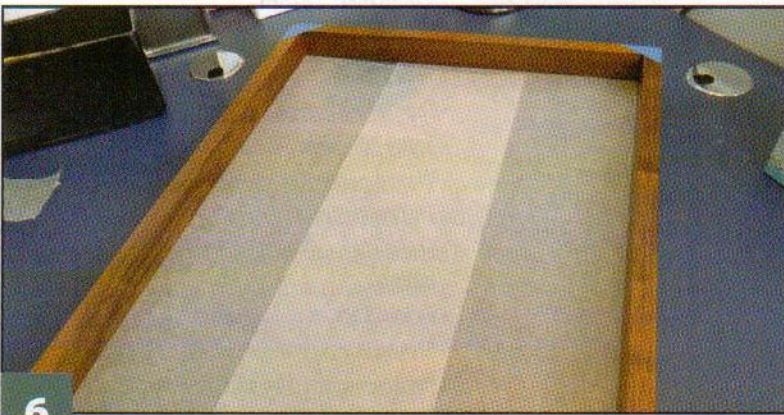

**6** **Cut the backing board to fit within the frame.** Leave it in the frame and cover the visible parts with tracing paper and then waxed paper. This allows you to finish gluing the remaining pieces together and trace them onto the backing board. Glue the sections together, but do not glue the project to the frame yet. Allow the glue to dry.

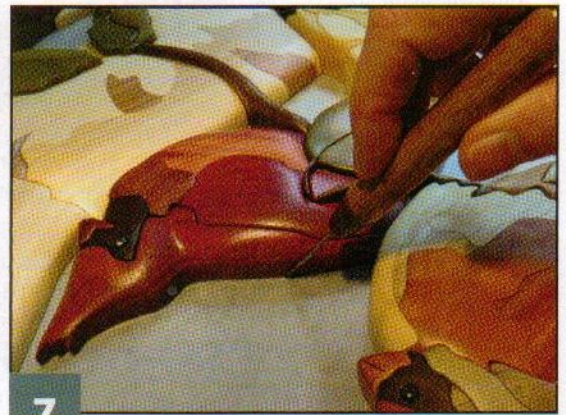

**7** **Trace the assembled project onto the backing board.** Use an awl to trace around the edges, including the exposed inside edges of the frame. Mark the open spaces with an X so you know where to drill blade-entry holes.

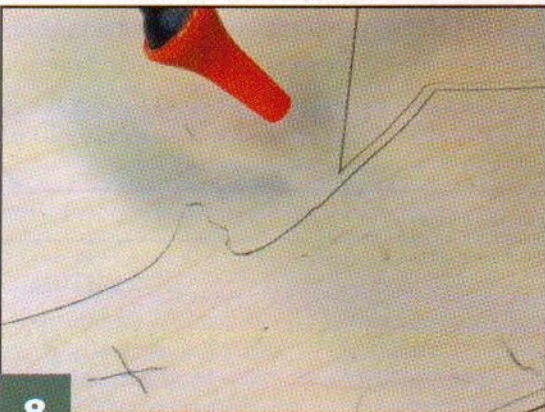

**8** **Drill the blade-entry holes.** Cut the backing board with a #2 blade. Mask off the back side of the backing board and apply several light coats of black spray paint to the edges and the top of the backing board close to the edges. Leave some bare wood in the inner areas to ensure a good glue joint. Allow the paint to dry, and remove the tape.



**9** **Set the project on the backing board and check the fit.** Carefully remove the project and apply glue to the backing board. Only apply glue to the project, not the frame. Do not apply glue to the areas of the backing board that touch the frame. Clamp or weigh down the intarsia and allow it to dry thoroughly. Lift off the frame and apply glue to the edges and remaining backing board that will be glued to the frame itself. Carefully return the frame to the project. Clamp the edges well and allow it to dry. Attach two hangers to the back. Label the back with your wood choices, if desired.

**Materials:**

Because of grain variations, try to choose larger blanks to take advantage of the wood grain. Listed below are the minimum sizes you will need. The woods listed are suggestions only; there are other species that may be close to the colors you need.

Chickadee, all wood is 1" (25mm) thick

- Sycamore: 2" x 4" (51mm x 102mm)
- Peruvian walnut: 3" x 4" (76mm x 102mm)
- Blue pine: assorted scraps
- Birch: 2" x 4" (51mm x 102mm)
- Aspen: 2" x 2" (51mm x 51mm)

Nuthatch, all wood is 1" (25mm) thick

- Peruvian walnut: 3" x 5" (76mm x 127mm)
- Dark gray blue pine: 4" x 5" (102mm x 127mm)
- Light gray blue pine: 2" x 4" (51mm x 102mm)
- Aspen: 3" x 5" (76mm x 127mm)

Male cardinal, all wood is 1" (25mm) thick

- Peruvian walnut: 2" x 2" (51mm x 51mm)
- Redheart: 3" x 5" (76mm x 127mm)
- Bubinga: 3" x 4" (76mm x 102mm)
- Red cedar: 4" x 6" (102mm x 152mm)

Female cardinal, all wood is 1" (25mm) thick

- Juniper: 4" x 5" (102mm x 127mm)
- Blue pine: 3" x 5" (76mm x 127mm)
- Red cedar: 2" x 4" (51mm x 102mm)
- Figured redwood: 3" x 5" (76mm x 127mm)
- Peruvian walnut: 1" x 2" (25mm x 51mm)
- Hackberry: 3" x 5" (76mm x 127mm)

*The author used these products for the project. Substitute your choice of brands, tools, and materials as desired.*

Goldfinch, all wood is 1" (25mm) thick

- Peruvian walnut, 2" x 5" (51mm x 127mm)
- Yellowheart: 2" x 4" (51mm x 102mm)
- Yellow cedar: 2" x 8" (51mm x 203mm)
- Padauk: 2" x 4" (51mm x 102mm)
- Aspen: 2" x 4" (51mm x 102mm)

Bluebird, all wood is 1" (25mm) thick

- Aspen: 2" x 4" (51mm x 102mm)
- Buckeye: small scrap for beak
- Light redwood: 3" x 5" (76mm x 127mm)
- Blue pine: 2" x 4" (51mm x 102mm)
- Dark redwood: 2" x 3" (51mm x 76mm)
- Alder, stained blue: 2" x 6" (51mm x 152mm)

Trees, all wood is 5/8" (16mm) thick

- Birch (medium wood): 7" x 30" (178mm x 762mm)
- Aspen (light wood): 10" x 30" (254mm x 762mm)
- Walnut (dark wood): 4" x 8" (102mm x 203mm)
- Butternut (medium-dark): 5" x 18" (127mm x 457mm)

Branches, all wood is 1" (25mm) thick

- Aspen (light wood): 5" x 7" (127mm x 178mm)
- Birch (medium wood): 3" x 12" (76mm x 305mm)
- Butternut (medium dark): 3" x 8" (76mm x 203mm)
- Walnut (dark wood): 5" x 6" (127mm x 152mm)

Leaves, all wood is 1" (25mm) thick

- Light green poplar: 6" x 13" (152mm x 330mm)

- Dark green poplar: 4" x 16" (102mm x 406mm)

- Dowels, 3/16" (5mm) dia.: assorted scraps for eyes
- Baltic birch plywood, 1/8" (3mm) to 1/4" (6mm) thick: assorted scraps for risers
- Baltic birch plywood, 1/8" (3mm) thick: backing board, 18" x 25" (457mm x 635mm)

Frame

- Walnut, 3/4" (19mm) thick: 1 1/2" x 88" (38mm x 2235mm)

- Sandpaper: 220 grit
- Sanding sponge
- Wood glue
- Tape: masking, packaging
- Spray adhesive
- Waxed paper
- Tracing paper
- Stain, such as Minwax Express Color: indigo
- Finish, such as gel varnish
- Strong D-ring hangers: 2 each
- Permanent marker, such as Sharpie: wide, fine points
- Spray paint: flat black

**Tools:**

- Table saw or router
- Drill with bit: 3/16" (5mm) dia., assorted small
- Scroll saw blades: #2, #7 reverse-tooth
- Sander: flexible drum, 120, 220 grits
- Sander: mop
- Rotary tool with carving bit (optional for texturing)

Pattern for the **SPRING GATHERING** is in the pattern pullout section.



Janette Square lives in Yachats, on the Oregon coast. For more of her work, visit her website at [www.square-designs.com](http://www.square-designs.com).

# Fretwork Heart

Make this wall hanging for Mom or customize it for another special person

By Sue Mey  
Cut by Rolf Beuttenmuller

This intricate and attractive wall hanging will put a smile on any mother's face. It's also simple to swap out "Mom" for another three-letter word or even another special someone's initials using a word-processing program. Regardless, this wall hanging makes a beautiful gift.

## Getting Started

While you can cut the heart from plywood, I suggest using a colorful hardwood. If you cut it from  $\frac{3}{8}$ " (10mm)- to  $\frac{1}{2}$ " (13mm)-thick wood, you can forgo the backing board, but I highly recommend adding a painted or stained plywood backing board if you cut it from  $\frac{1}{8}$ " (3mm)- to  $\frac{1}{4}$ " (6mm)-thick hardwood. I also suggest stack-cutting the thinner blanks for additional support; this is a fragile design. Cover the blank or stack with blue painter's tape and transfer the pattern to the blank or top of the stack.

## Materials & Tools

### MATERIALS:

- Hardwood,  $\frac{1}{8}$ " (3mm) to  $\frac{1}{2}$ " (13mm) thick:  $8\frac{1}{2}$ " x 10" (216mm x 254mm)
- Baltic birch plywood,  $\frac{1}{8}$ " (3mm) thick: optional backing board,  $8\frac{1}{2}$ " x 10" (216mm x 254mm)
- Spray adhesive
- Tape: blue painter's
- Sandpaper

- Finish
- Glue: cyanoacrylate (CA) glue or epoxy
- Hanger

### TOOLS:

- Scroll saw blades: #1 reverse-tooth
- Drill with bits: assorted small

The author used these products for the project. Substitute your choice of brands, tools, and materials as desired.

## Making the Plaque

Drill blade-entry holes and cut the frets. If you plan to add a backing board, turn the stack over, attach the backing board pattern to the bottom of the stack, and cut the perimeter. Then, remove the backing board, flip the stack, and cut the intricate perimeter of the fretwork heart. Sand the cut pieces and apply a finish of your choice. Use cyanoacrylate (CA) glue or epoxy to secure the heart to the backing board and to attach a hanger to the back.

Patterns for the **FRETWORK HEART** are in the pattern pullout section.



Sue Mey lives in Pretoria, South Africa. To see more of her work, including a wide variety of patterns and pattern-making tutorials available for purchase, visit [www.scrollsawartist.com](http://www.scrollsawartist.com). She can be contacted at [suem@storage.co.za](mailto:suem@storage.co.za). Her pattern book, *Lighted Scroll Saw Projects*, is available from [www.schifferbooks.com](http://www.schifferbooks.com) and other outlets.



# Air Plant Holders

Compound-cut cool cubbies for these popular plants

By Sue Mey  
Cut by Rolf Beuttenmuller



**E**xotic air plants seemingly thrive on oxygen alone, so they can be tucked into all kinds of cool containers. Show off your scrolling skills by making custom wooden holders for these popular plants.

Because large pieces of wood won't fit in a scroll saw, I cut four smaller pieces and glue them together into one large piece. The success of the project depends on two factors: precisely cutting or sanding the blanks to size before applying the patterns, and carefully and consistently cutting on the pattern lines. If the clearance on your saw does not allow you to cut the almost 2" (51mm)-thick material, reduce the size of the pattern slightly and use the largest wood your saw will accommodate.

## About Air Plants

Tillandsia is the largest genus in the Bromeliad family, accounting for approximately 550 of the more than 2,500 species of Bromeliads. Commonly known as air plants, they are found in both jungle



rain forests and arid desert environments, from sea level to high mountain regions. These hardy plants are tolerant to a wide range of environmental conditions and require minimal care. The three most important requirements are bright light (although not direct sun), good air circulation, and water. Remember, if humidity is very low, watering one to two times weekly is necessary for healthy, thriving plants. For more on air plants, visit [www.airplantsupplyco.com](http://www.airplantsupplyco.com).

## Getting Started

To make these large 3-D projects, make four copies of each pattern. Use a table saw to cut the blanks to size. You can also cut them with a saw of your choice and use a disc sander or belt sander to sand the blanks to the exact dimensions. Cover the blanks with masking tape or blue painter's tape. Fold the patterns on the centerlines, apply adhesive to the backs of the patterns, align the folds with the corners of the blanks, and press the patterns into place.

## Making the Holders

Drill  $\frac{1}{8}$ " (3mm)-diameter blade-entry holes in both sides for the frets (where applicable). Using a #9 blade, cut the frets on one side, and then cut the perimeter. Saw all the way through the wood but stop just before cutting the paper free, leaving the pattern intact, which makes it easier to cut the other side. Vacuum away the dust and tape the waste pieces back in place. Rotate the blank and cut the second side. Carefully remove the completed section from the waste, and peel off any remaining pattern or tape. After making the final cuts, save the outer waste pieces.

Carefully match the outer waste pieces and the inner pieces—this will give you square sides to clamp to; rubber bands work well as clamps. Glue and clamp together two pieces, each representing a quarter of the completed project. Make sure the pieces line up nicely. Use great care not to get any glue on the outer pieces. Assemble the other half using the same technique. Allow the glue to dry. Then, glue and clamp the two halves together. When the glue has dried, remove clamps or rubber bands, and put aside the outer waste pieces to be used later when drilling. Hand-sand the outside surfaces and remove any irregularities.

## Drilling the Plant Openings

Drill the openings for the plants where indicated on the patterns (if applicable). Match the outer waste—this will give you square sides to hold onto while drilling (although placing the project in a holding jig for drilling is still recommended). Use a drill press for this step. It's challenging and unsafe to drill a straight hole with a Forstner bit with a handheld drill.

Make sure the drill press table and the drill bit are perpendicular, both side to side and front to back. Set the drill to the slowest possible speed. Flatten both the top and bottom of the project with a belt or disc sander. Mark the center of the hole with a punch or awl. For some projects, drilling to the proper depth may require an extension for the Forstner bit. Before adding the extension, drill to the maximum depth possible with a standard bit. Drill in  $\frac{1}{2}$ " (13mm)

increments. After each increment, back the bit completely out of the work piece and remove all wood shavings and dust before resuming. Soften the drilled edges with sandpaper if needed.

## Sealing the Project

Apply several thin coats of clear spray varnish, or a finish of your choice, to seal the wood. Remember, these holders will be getting wet, so choose a waterproof finish. For hanging holders without a fret opening at the top, insert screw eyes or screw bolts to thread a string or cord through.

## Adding the Air Plants

Arrange an air plant in the holder. Many look very nice just sitting or hanging in the holder with no mounting at all and can be removed from the holder for watering.

To secure a plant in the upside-down holders, choose a strong, waterproof adhesive, such as E6000, which is colorless, extremely strong, waterproof, and nontoxic to plants. Apply a small amount of adhesive near the base of the plant, but not on the bottom. Avoid covering the area where the roots form. Using soft, coated wire, such as telephone wire or floral wire, tie the plant securely in place until the adhesive sets. In case of secured plants, use a waterproof varnish for the holder so you can spray the plants with water.

Patterns for the **AIR PLANT HOLDERS** are in the pattern pullout section.

## Materials & Tools

### MATERIALS:

- Wood, such as basswood:  
1 $\frac{7}{8}$ " (48mm) square: 4 each,  
sized to fit pattern
- Tape: masking or blue  
painter's tape, clear packaging
- Adhesive: temporary bond  
spray or glue stick
- Sandpaper
- Glue: wood, waterproof  
adhesive such as E6000
- Waterproof finish, such as  
clear spray varnish
- Screw eyes: small
- Rubber bands (optional)

### TOOLS:

- Table saw  
OR saw of choice with  
disc or belt sander
- Scroll saw blades:  
#9 skip-tooth
- Drill press with bits:  
 $\frac{1}{8}$ " (3mm)-dia. twist,  
2" (51mm)-dia. Forstner
- Stiff-bristled paintbrush  
(to remove sawdust or  
sanding dust)
- Clamps

*The author used these products for the project. Substitute your choice of brands, tools, and materials as desired.*



Sue Mey lives in Pretoria, South Africa. To see more of her work, including a wide variety of patterns and pattern-making tutorials available for purchase, visit [www.scrollsawartist.com](http://www.scrollsawartist.com). She can be contacted at [suem@storage.co.za](mailto:suem@storage.co.za). Her pattern book, *Lighted Scroll Saw Projects*, is available from [www.schifferbooks.com](http://www.schifferbooks.com) and other outlets.

# Cat Puzzles

An assortment of designs purr-fect for the feline lovers in your life

By Eric Van Malderen



Cats. You love them or you hate them. There are more than 600 million of them worldwide, and they are found in almost every place humans live. Cats have been worshipped as gods of fertility and protectors of possessions, seen as witches' familiars, and shunned as bad luck. Some people collect items related to cats—dolls, portraits, books, etc. One collector asked me for something that she didn't have yet: a cat puzzle. It was a perfect occasion for me to design a range of puzzles. Drawing the contour of a cat is not very difficult. You can find all kinds of silhouettes on the Internet without copyright. For these designs, I mixed free silhouettes with my own drawing skills.

## TIP

### MAKING A SCENE

Scroll the angry cat twice and place them face-to-face to make two fighting cats.

## Making the Puzzles

The color and the grain accent determine the overall look of these puzzles. I chose meranti for the sweet cat, rubberwood for the angry cat, and pine for the sleeping cat. Attach the pattern to the wood. Cover it with clear packaging tape to reduce the chance of scorching and to lubricate the blade. Scroll the puzzle and sand very carefully. You can use a flap sander to round the edges or sand it by hand. Finish all pieces with clear Danish oil.

## Materials & Tools

### Materials:

- Hard or soft wood,  $\frac{3}{4}$ " (19mm) thick: sized to fit patterns
- Spray adhesive, repositionable
- Sandpaper: 180, 220 grits
- Clear packaging tape
- Danish oil

*The author used these products for the project. Substitute your choice of brands, tools, and materials as desired.*

### Tools:

- Blades: #5 skip reverse-tooth
- Sanding disc or flap sander

## Cat puzzle patterns

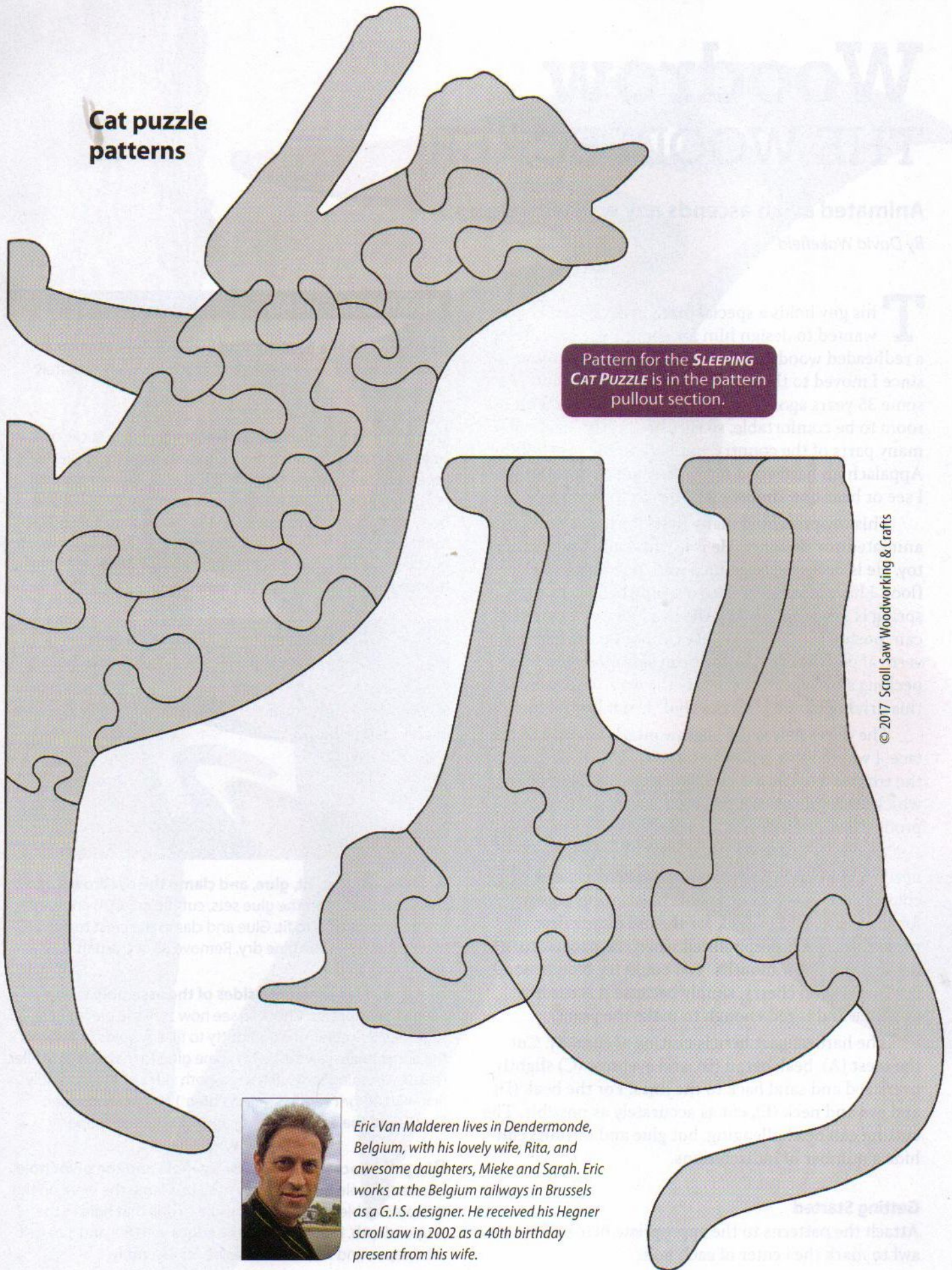

Pattern for the **SLEEPING CAT PUZZLE** is in the pattern pullout section.

© 2017 Scroll Saw Woodworking & Crafts



*Eric Van Malderen lives in Dendermonde, Belgium, with his lovely wife, Rita, and awesome daughters, Mieke and Sarah. Eric works at the Belgium railways in Brussels as a G.I.S. designer. He received his Hegner scroll saw in 2002 as a 40th birthday present from his wife.*

# Woodrow

## THE WOODPECKER

### Animated avian ascends any wall with ease

By David Wakefield

**T**his guy holds a special place in my heart. I have wanted to design him for about two years. Being a redheaded woodworker, he has been my “familiar” since I moved to the woods of southeastern Ohio some 35 years ago. Pileated woodpeckers need a bit of room to be comfortable, so they are pretty scarce in many parts of the country, but here in the heart of the Appalachian hardwood forest they are quite common. I see or hear one almost every day in the woods.

This toy presented many firsts for me as an animated-toy designer. He is my first and only vertical toy. He is designed to go up a wall, not across the floor. I have also never used a spring before (the spring is needed to return the head forward after the cam pushes it back, as gravity cannot do the job in a vertical position). An unforeseen side effect is a loud pecking sound as his beak hits the wall. The irony of this driving parents “up the wall” is not lost on me!

The other first is the “jigsaw puzzle” nature of the face. I wanted this fellow to look “real.” It is well worth the trouble. He has me taking classes in CNC routing, which is the only way I could put this wild guy into production efficiently.

The main difficulty of making this guy is the head. The woodpecker’s head has red, black, and white coloring. I chose walnut for the black, tulip poplar for the white, and padauk for the red on my first prototype. I was disappointed when the padauk turned brown after a few months. You could try bloodwood, but I settled on cherry, simply because it is readily available and is red enough to make the point.

The hardest part here is cutting accurately. Cut the crest (A), beak detail (B), and eyebrow (C) slightly oversized and sand back to the lines. For the beak (D) and eye and neck (E), cut as accurately as possible. The cutting can be challenging, but glue and sawdust can hide a number of indiscretions.

#### Getting Started

Attach the patterns to the appropriate blanks. Use an awl to mark the center of each hole.

#### MAKING THE HEAD

**Step 1: Cut the beak (D) and eye and neck (E).** Use a scroll saw with a small blade to cut the pieces as accurately as possible.

**Step 2: Fit the pieces together.** Use sanding sticks or a small riffler file to remove any high spots until these pieces fit together. Then, cut the beak detail (B) and fit it into the oval hole. Apply glue to the mating surfaces of the beak (D) and body and neck (E), and assemble the pieces. Add some glue to the edges of the beak detail (B) and slip it into the hole. It’s not possible to clamp these pieces, so allow the glue to dry thoroughly before moving the assembly.



**▲ Step 3: Cut, fit, glue, and clamp the eyebrow (C) to the assembly.** After the glue sets, cut the crest (A) and sand the head assembly to fit. Glue and clamp the crest to the assembly and let the glue dry. Remove all of the patterns.

**Step 4: Flat-sand both sides of the assembly with 80-grit sandpaper.** Check to see how well the pieces fit together. Use colored wood putty to fill any voids or just mix the appropriate sawdust with some glue to make a paste filler. Once everything is dry, flat-sand both sides of the assembly first with 80-grit sandpaper and then 120-grit sandpaper. Then, sand the edges with 80- and 120-grit sandpaper.

**Step 5: Locate and drill the eyehole and the pivot hole.** Locate the hole for the spring to sit in. Clamp the work on the drill press table at the proper angle to drill that hole to the proper depth. Hand-sand all the edges with 80- and 120-grit sandpaper, and set the head aside for assembly.



## MAKING THE WINGS AND BODY

**Step 6:** Cut both sides of the body (F). Edge-sand the areas where the spacer will not reach (the front and wheel areas). Remove the patterns, flat-sand both sides of each piece with 80-grit sandpaper, and sand just the outside surfaces of each piece with 120-grit sandpaper.

**Step 7:** Cut the spacer (G). Carefully mark the hole location for the spring (M). Clamp the piece in position on the drill press. Then, drill the hole for the spring.



**▲ Step 8:** Apply glue to both sides of the spacer. Clamp the sides on either side of the spacer, being careful to put the good sides out and to line everything up accurately. After the glue dries, drill the axle and pivot holes. Use a round-over bit in a router to remove the sharp corners of the entire assembly. Then, hand-sand the rounded edges with 80- and 120-grit sandpaper.

**Step 9:** Cut the wings (H). Edge-sand both silhouettes with 80- and 120-grit. Flat-sand both sides with 80-grit sandpaper and just the outside surfaces with 120-grit sandpaper. Use the router with a round-over bit to remove the sharp corners of the outside edges of the wings. Hand-sand the rounded edge with 80- and 120-grit sandpaper.

## MAKING THE WHEELS AND CAM

**Step 10:** Cut the wheels (I) and cam (J). You can cut them with a scroll saw, but a 2" (51mm)-diameter hole saw makes a circle close to 1 3/4" (44mm) diameter, and a 1 1/4" (32mm) diameter hole saw will make a circle close to 1" (25mm).

**Step 11:** Fill the center hole in the cam. Then, use the pattern to drill an off-center hole. Enlarge the axle holes in the wheel to 5/16" (8mm) diameter. Edge-sand both wheels and the

cam lightly with 80-grit sandpaper (being careful to maintain the circular shape). Then, round or "break" the edges by hand with sandpaper.

## ASSEMBLING THE PROJECT

**Step 12:** Position the head between the body sides with the pivot holes lining up. Tap the 5/16" (8mm)-diameter dowel through the near side of the body until it slips through the hole in the head assembly and just enters the hole on the far side of the body. Then, put a bit of glue on the insides of the hole on the back side of the body and around the dowel protruding on the near side. With the work on some waxed paper, drive the dowel home. Wipe off any excess glue letting it dry thoroughly. Flat-sand both sides with 120-grit sandpaper, removing any protruding dowel that might interfere with the wings being glued on flat.

**Step 13:** Carefully position the wings identically as you glue and clamp them to the body. With the head pivoted downward, use needle-nose pliers to position the spring in its respective holes, and bring the head up in position. Check to make sure that the spring is totally seated in both holes, as it's a bit hard to get at after assembly.

**Step 14:** Apply glue to the inside of one of the wheel axle holes. Then, set it on some waxed paper on the workbench and drive the axle home. Wipe off any excess glue. Position the cam between the body sides and slip the axle through. Put the remaining wheel on the waxed paper with glue inside the axle hole. Hold the assembly over that wheel as you hammer the outside of the first wheel to drive the axle home into the second wheel. Wipe off excess glue.

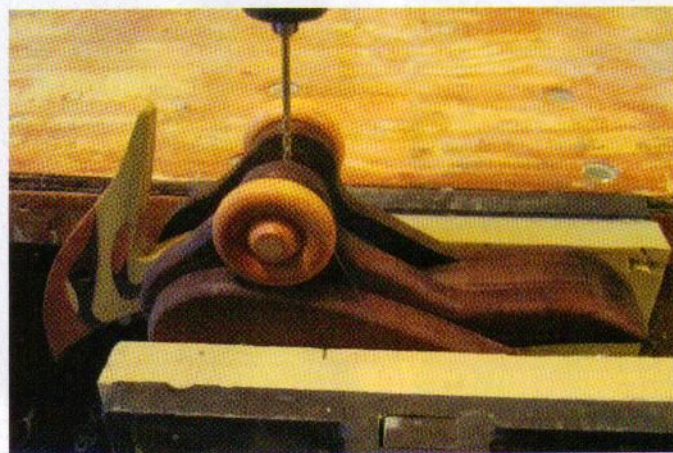

**▲ Step 15:** Flip the project upside down and clamp it in a vise. Make sure the thin part of the cam is facing up. Then, drill the 1/8" (3mm)-diameter peg hole in the cam with a handheld drill. Be sure that nothing shifts while you put a little glue in the hole and drive the 1/8" (3mm)-diameter dowel in place. When the glue has dried, sand the end of the 1/8" (3mm)-diameter dowel flush to the cam's surface and edge-sand the ends of the axle.

## Materials & Tools

### Materials:

- Cherry, 3/4" (19mm) thick:  
1" x 3 3/4" (25mm x 95mm)
- Tulip poplar, 3/4" (19mm) thick:  
3" x 4 1/2" (76mm x 114mm)
- Walnut, 3/4" (19mm) thick:  
2 1/2" x 5 1/2" (64mm x 140mm)
- Walnut, 1/2" (13mm) thick:  
4" x 32" (102mm x 813mm)
- Walnut, 7/8" (22mm) thick:  
2" x 8 1/2" (51mm x 216mm)
- Pine, 1/2" (13mm) thick:  
1" (25mm) square
- Dowel, 5/16" (8mm) dia.:  
5 1/4" (133mm) long
- Dowel, 1/8" (3mm) dia.:  
1/2" (13mm) long
- Cherry, 1/2" (13mm) thick:  
2" x 4" (51mm x 102mm)  
OR commercial wheels:  
2 each 1 3/4" (44mm) dia.
- Compression spring,  
3/8" (10mm) dia.:  
1 1/2" (38mm) long
- Sandpaper: 80, 120 grits
- Wood glue
- Colored wood filler (optional)
- Finish, such as mineral oil
- Waxed paper
- Drill: handheld, drill press
- Drill bits: 1/8" (3mm),  
1/4" (6mm), 5/16" (8mm),  
3/8" (10mm)-dia. twist
- Hole saws: 1 1/4" (32mm),  
2" (51mm) dia.
- Sanding sticks OR  
riffle file
- Pliers, needle-nose
- Hammer
- Clamps
- Router with bit:  
1/4" (6mm)-radius  
round-over
- Vise

### Tools:

- Scroll saw blades:  
#5 reverse-tooth

*The author used these products for the project. Substitute your choice of brands, tools, and materials as desired.*



### The Spring

You want a very light spring that is 3/8" (10mm) diameter by 1 1/2" (38mm) long with coils about 1/4" (6mm) apart. You can either go to a hardware store and look at their spring assortment, or you can go online to [www.truevalue.com](http://www.truevalue.com) and order part #682096.

They come in packs of four for about \$4 plus shipping.

### Finishing the Woodpecker

I use mineral oil for a finish these days. Apply the oil liberally with a rag, allow it to soak in for an hour, and wipe off any excess. You can apply another coat if necessary, and you can also do this again at any point in the future if it looks like it needs some more oil.

Woodrow can be rolled across the floor, but woodpeckers really prefer to be vertical, don't they! Sometimes, a pair of noise-canceling headphones can come in handy for parenting.

### Parts List

	Item	Materials	Quantity	Dimensions	Presentation
<b>A</b>	Crest	Cherry, 3/4" (19mm) thick	1	1" x 3 3/4" (25mm x 95mm)	Pattern
<b>B</b>	Beak detail	Cherry, 3/4" (19mm) thick	1	3/8" x 1" (10mm x 25mm)	Pattern
<b>C</b>	Eyebrow	Tulip poplar, 3/4" (19mm) thick	1	1/4" x 3/4" (6mm x 19mm)	Pattern
<b>D</b>	Beak	Tulip poplar, 3/4" (19mm) thick	1	3" x 4 1/2" (76mm x 114mm)	Pattern
<b>E</b>	Eye and neck	Walnut, 3/4" (19mm) thick	1	2 1/2" x 5 1/2" (64mm x 140mm)	Pattern
<b>F</b>	Body sides	Walnut, 1/2" (13mm) thick	2	4" x 8 1/2" (102mm x 216mm)	Pattern
<b>G</b>	Body spacer	Walnut, 7/8" (22mm) thick	1	2" x 8 1/2" (51mm x 216mm)	Pattern
<b>H</b>	Wings	Walnut, 1/2" (13mm)	2	2 1/4" x 7" (57mm x 178mm)	Pattern
<b>I</b>	Wheels	Cherry, 1/2" (13mm) thick, or commercial wheel with 5/16" (8mm)-dia. axle hole	2	1 3/4" (44mm) dia.	Pattern
<b>J</b>	Cam	Pine, 1/2" (13mm) thick	1	1" (25mm) dia.	Pattern
<b>K</b>	Axle	Dowel, 5/16" (8mm) dia.	1	3 1/2" (89mm) long	Dimensions
<b>L</b>	Pivot	Dowel, 5/16" (8mm) dia.	1	1 3/4" (44mm) long	Dimensions
<b>M</b>	Spring	3/8" (10mm)-dia. compression	1	1 1/2" (38mm) long	Dimensions
<b>N</b>	Cam pin	Dowel, 1/8" (3mm) dia.	1	1/2" (13mm) long	Dimensions

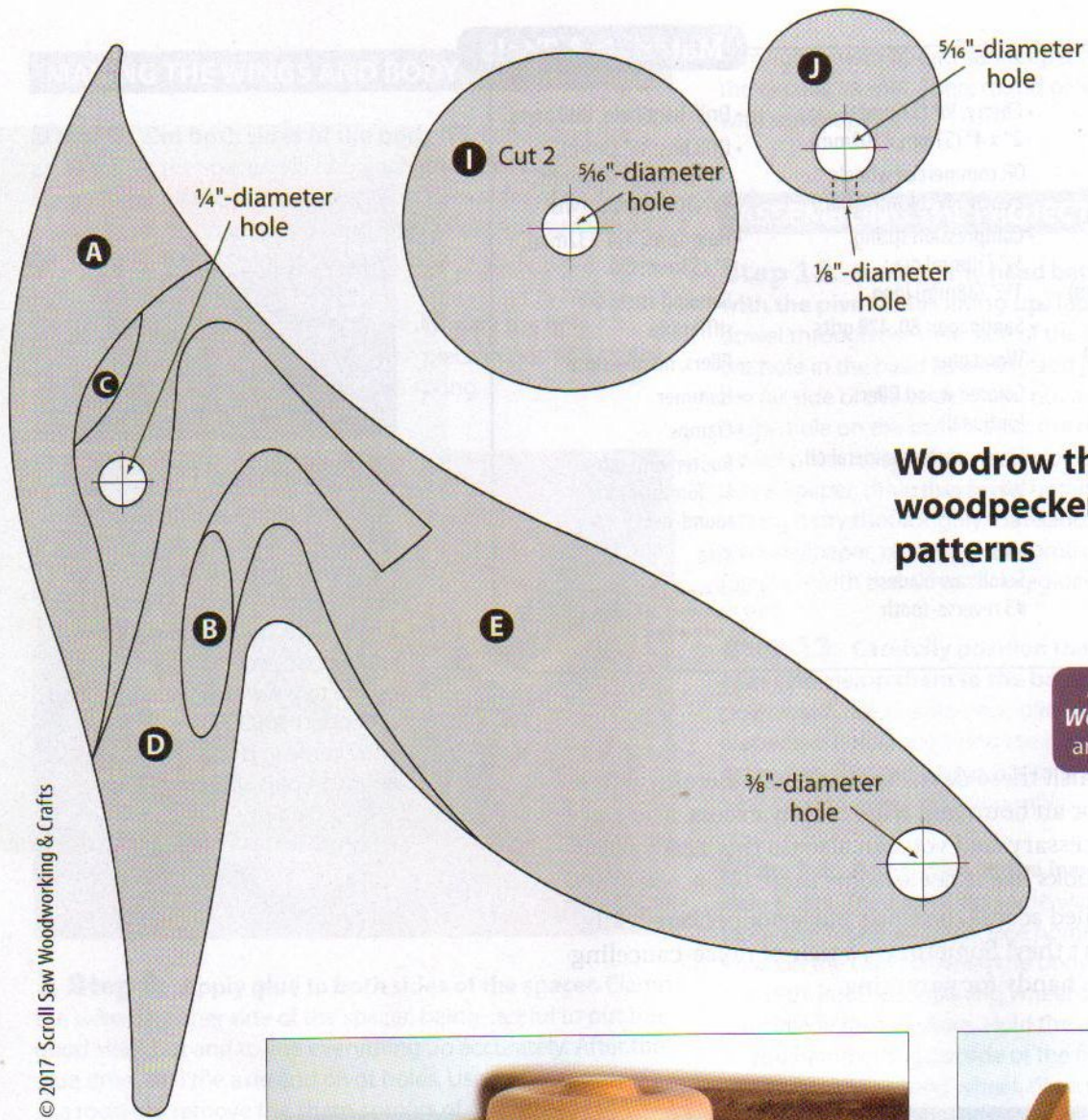

### Woodrow the woodpecker patterns

Additional patterns for *WOODROW THE WOODPECKER* are in the pullout section.

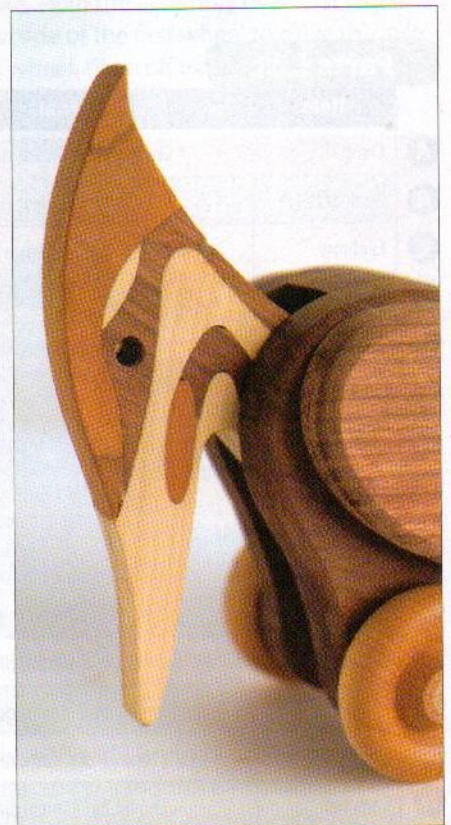

David Wakefield's love for wildlife, combined with his down-to-earth designing and woodworking skills, results in an uncanny ability to capture the character and movement of creatures in hardwood for children (and adults) to play with. David lives in Ohio, where he has been designing toys for 35 years.

# Nosy Dragon Shelf Sitter

Freestanding puzzle watches you work and defends your desk

By Judy and Dave Peterson



I've christened this cutie pie "Nosy." I designed him back when computer monitors were much larger, so he could comfortably sit on a monitor watching you work. Although he doesn't sit well on a flat-screen monitor, he perches happily on a shelf or nearby filing cabinet.

## Making the Puzzle

Attach the pattern to the blank, paying attention to the grain-direction arrow, and cut the pieces. If you plan to run the puzzle through a stationary drum sander, make a single cut in from the edge of the blank. Cut the perimeter to keep the scrap wood around the outside intact, and then cut the pieces. To sand, assemble the puzzle in the waste wood, wrap a rubber band around it, and put it through the sander. Disassemble the puzzle and use a flap sander to round the edges of the pieces slightly. Apply a finish of clear Danish oil.

## Materials & Tools

### Materials:

- Chakte kok, 1" (25mm) thick: 6" x 7½" (152mm x 191mm)
- Sandpaper
- Finish: clear Danish oil

*The author used these products for the project. Substitute your choice of brands, tools, and materials as desired.*

### Tools:

- Blades: #7 skip-tooth
- Sanders: stationary drum; flap
- Brushes and rags

Pattern for the **SHelf-SITTER** PUZZLE is in the pattern pullout section.



A former teacher and librarian, Judy Peterson found her niche in life as a woodworker. A winner of many design awards, she sells her puzzles at art shows around the country. Her husband, Dave, runs the record-keeping side of the business. Together they have written several books, which are available at

[www.foxchapelpublishing.com](http://www.foxchapelpublishing.com).

# Duck Wall Hanger

Instant color lets  
you finish this  
project in no time

By John A. Nelson



**H**aving trouble getting all your ducks in a row? This is a chance for you to fix that! Here is a cute wall rack that will add character to any child's bedroom. We did all the color work for you, so you can finish the project in no time.

## Making the Duck Wall Hanger

Cut the blank to size, sand it with medium-grit sandpaper, and remove the sanding dust. Make a color photocopy of the pattern (or download and print from our website, [www.scrollsawer.com](http://www.scrollsawer.com)) and cut the artwork along the two sides and bottom only. Apply a light, smooth coat of white glue or Mod Podge over the entire front surface of the wood, running the glue to the edges. Make sure there are no lumps or ridges. Align the bottom and two ends of the artwork with the edges

of the wood and press it into place. Carefully smooth the artwork on the wood and let the glue dry thoroughly.

Drill three holes for the shaker pegs. Drill three blade-entry holes for the open wing sections and make the cuts. Cut the perimeters of the ducks. Lightly sand the edges to remove any burrs. If desired, paint the edges of the ducks yellow, the beaks orange, and everything else light blue. Do not get any paint on the front surface. Apply two or three coats of clear coat and let dry.

Buff the entire surface with #0000 steel wool to reduce the surface glaze slightly. Paint the three shaker pegs and glue them in place. Apply a coat of paste wax to the entire project.

## Duck wall hanger pattern

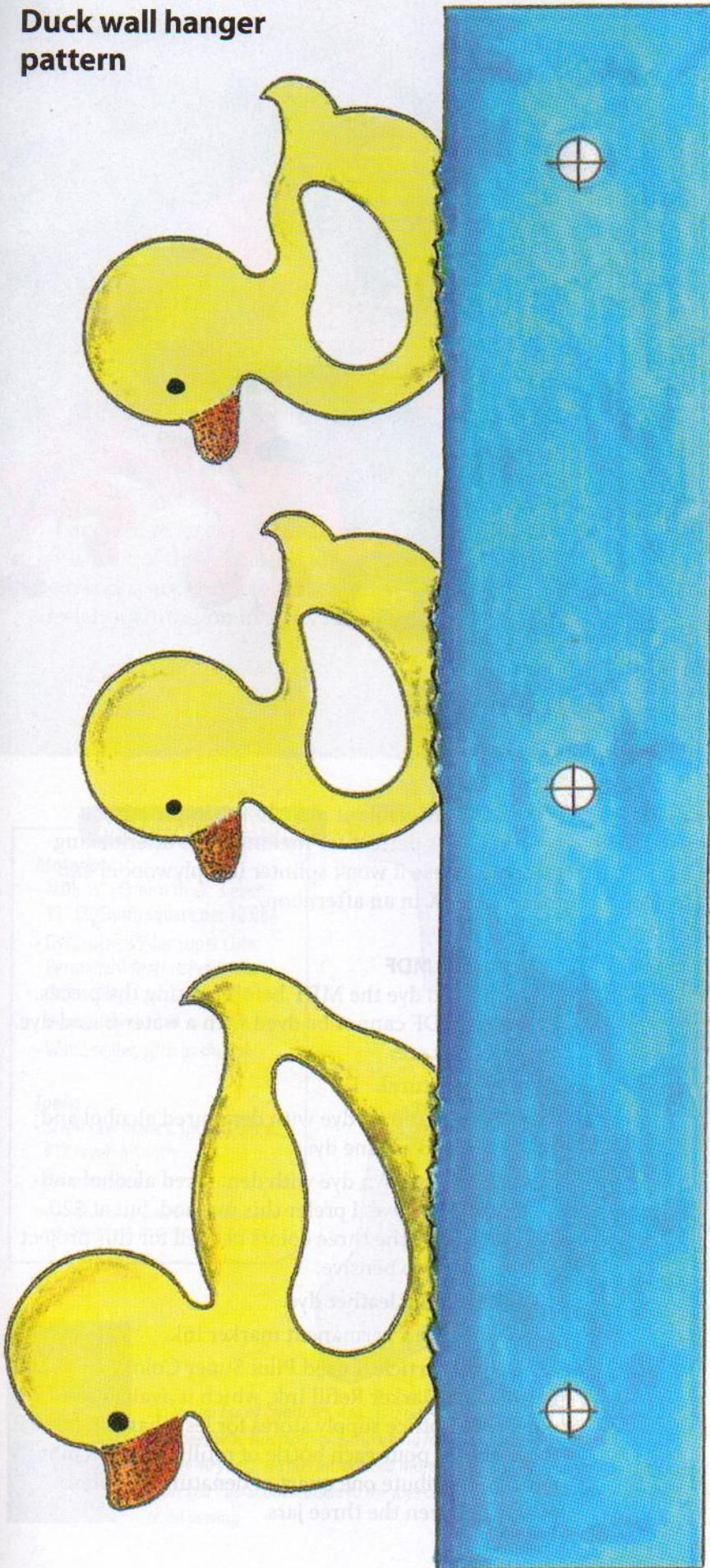

© 2017 Scroll Saw Woodworking & Crafts

### Materials & Tools

#### Materials:

- Baltic birch plywood, 1/2" (13mm) thick: 4 1/4" x 9 7/8" (108mm x 251mm)
- Shaker pegs: 1 3/4" (44mm) long
- White glue or Mod Podge
- Sandpaper: 150 grit
- Acrylic paint (optional): yellow, orange, light blue
- Spray finish: clear satin or glossy
- Steel wool: #0000
- Paste wax

#### Tools:

- Scroll saw blades: #2 or #5
- Drill with bit: 1/8" (3mm), 1/2" (13mm)-dia. twist

*The author used these products for the project. Substitute your choice of brands, tools, and materials as desired.*

**ON THE WEB** Duck Wall Hanger color pattern download.  
[www.scrollsawer.com](http://www.scrollsawer.com)



John A. Nelson is the author of Fox Chapel's popular Scroll Saw Workbook, available at [www.foxchapelublishing.com](http://www.foxchapelublishing.com).

# GEX

(The Anti-Jigsaw Puzzle)

Gecko-shaped tessellating tiles are an addictive toy

By Dave Van Ess



**G**EX stands for “gecko hexagon tessellating tiles.” Tessellation is just a fancy word meaning shapes that repeat over and over again to cover a surface without any gaps or overlaps. It’s like a jigsaw puzzle, except that instead of having many shapes and one solution, you have one shape and many solutions. (So it’s really an anti-jigsaw puzzle, now that I think of it.) You can make all kinds of shapes with the pieces. It is addictively fun.

I adapted this pattern from one shared by “buchananwp” and his friends at Instructables.com. They developed it from an earlier open-source version, so use this pattern to your heart’s content.

These GEX are sized so that 36 of them will fit into a medium-sized USPS flat-rate mailer, which measures 3 $\frac{3}{8}$ " by 12" by 14". I find that 12 GEX are a good number to start with. However, people tend to find interesting patterns they could make if they just had another 12 GEX, so expect requests for more. Fortunately they are easy to make.

## Selecting the Wood

I used  $\frac{1}{2}$ " (13mm)-thick medium-density fiberboard (MDF). MDF is an engineered wood product made from wood fibers compressed with a wax or resin

binder. It is available at most home improvement centers and is perfect for making large interlocking pieces, because it won’t splinter like plywood. I can make 12 GEX in an afternoon.

## Coloring the MDF

It is easiest to dye the MDF before cutting the pieces. However, MDF cannot be dyed with a water-based dye. Your options are:

- Leave natural.
- Make your own dye with denatured alcohol and powdered aniline dye.
- Make your own dye with denatured alcohol and TransTint Dye. I prefer this method, but at \$20 per bottle, the three colors needed for this project would be expensive.
- Use diluted leather dye.
- Use diluted permanent marker ink.

For this article, I used Pilot Super Color Permanent Marker Refill Ink, which is available at most art or office supply stores for less than \$2. I buy three colors, pour each bottle of refill ink into a pint jar, and distribute one quart of denatured alcohol evenly between the three jars.

Apply the dye to one side of the MDF with a foam or bristle brush. Hold the MDF off the bench so the bottom does not get splotted. The dye will dry almost immediately.

### Cutting the GEX

You have several options when applying the pattern:

- Glue the pattern to the MDF and cut each GEX. Either forego the markings or apply them freehand with a permanent marker.
- Make a laser copy of the pattern, place it facedown on the MDF, and iron it in place. The heat will transfer the lines to the MDF. Cut the GEX and use a permanent marker or a woodburning tool to apply the markings.
- Use a laser to etch the pattern and design into the MDF.

I decided to laser-etch these examples because it saves a lot of time. I belong to a local community-based workspace that has a laser. There might be a similar organization in a city near you. It may be

called a maker space, hacker space, or tech center, but is really just a group of people with lots of cool tools and experience who are willing to share both with the public. Visit [www.scrollsawer.com](http://www.scrollsawer.com) for the vector pattern to laser etch.

Cut the GEX with a large blade; I use an Olson #12 reverse-tooth blade. This is the widest blade I could find that I could still cut curves with. Cut on the inside of the line.

### Sealing the Pieces

MDF soaks up water like a sponge, so I use shellac to seal the GEX. My recipe is to fill a quart jar one-third full of two-pound cut shellac sanding sealer and fill the rest of the jar with denatured alcohol. Put about an inch of this finish into an aluminum pie pan and briefly submerge each GEX into it. They will dry almost instantly and are ready to enjoy.

**ON THE WEB** Download a vector GEX pattern from our website.  
[www.scrollsawer.com](http://www.scrollsawer.com)

### Materials & Tools

#### Materials:

- MDF, 1/2" (13mm) thick: 3 each 12" (305mm) square per 12 GEX
- Dye, such as Pilot Super Color Permanent Marker Refill Ink: three colors
- Denatured alcohol
- Wood sealer, such as shellac

#### Tools:

- Scroll saw blades, such as Olson: #12 reverse-tooth
- Paintbrushes

*The author used these products for the project. Substitute your choice of brands, tools, and materials as desired.*



Dave Van Ess of Chandler, Ariz., is a retired engineer who has been woodworking for nearly 40 years. He has introduced more than 200 Cub Scout leaders to the joys of scroll sawing.

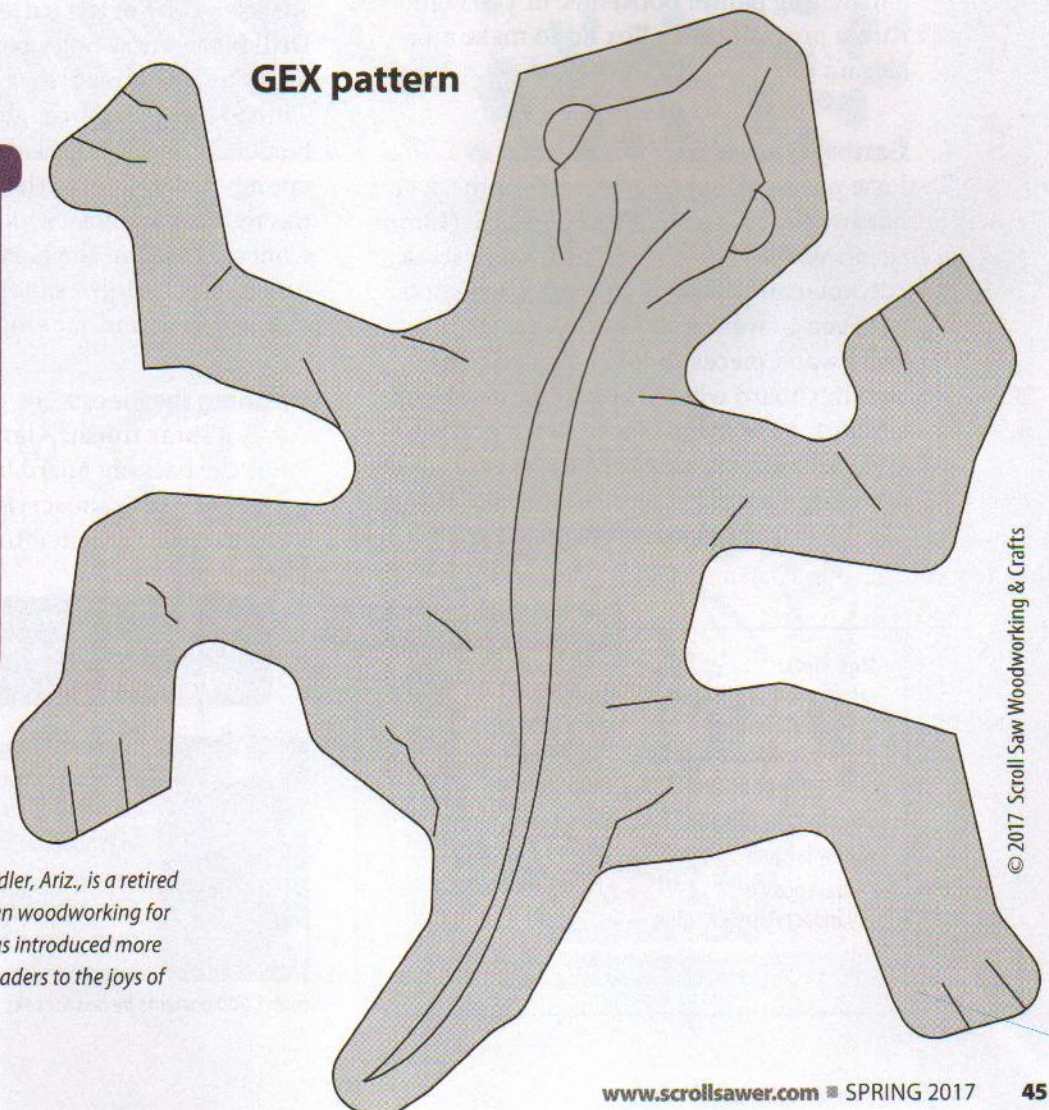

© 2017 Scroll Saw Woodworking & Crafts

# Fierce Felines

## Create your own pride with these three wild portraits

By Charles Dearing

**T**he leopard patiently waits for its prey to approach, lionesses work together to hunt their prey, and lions sit around and rule them all. With a bit of forethought, you could scroll a lioness and lion to make a matching pair of bookends, or you could turn a portrait into a box lid to make an elegant gift.

### Getting Started

I use plywood, but to cut portraits in hardwood, I suggest stock at least ½" (13mm) thick. While this is more difficult to stack cut, you can still sandwich the solid wood between a layer or two of thin plywood. Solid wood pieces should be glued to a backing board when finished for maximum support. I use spiral blades to cut portrait-style projects because they let you cut in any direction without rotating the wood. If you plan to frame the piece, create a stack of thin

plywood to protect the fragile fretwork. Cut the plywood to fit the frame and center the design on the plywood.

### Cutting the Fretwork

Attach a copy of the pattern to the blank. Drill blade-entry holes perpendicular to the blank for each fret area. Cut the waste areas. Thread the blade through the blade-entry holes. Carefully cut the design and keep the cutout pieces. Return the cutout pieces to the frets for stability while sanding. Sand the front and back of the portrait. I use a palm sander and 220-grit sandpaper. Remove the cutout pieces and sanding dust.

### Finishing the Pieces

Apply a spray finish. Allow the finish to dry. Paint the backing board black and attach it with epoxy or cyanoacrylate (CA) glue. Frame the portrait or attach it to a base or box.

### Materials & Tools

#### Materials:

- Hardwood or plywood, ⅛" to ½" (3mm to 13mm) thick: sized to fit the frame or project
- Sandpaper, 220 grit
- Spray lacquer
- Glue: epoxy or cyanoacrylate (CA) glue

The author used these products for the project. Substitute your choice of brands, tools, and materials as desired.

#### Tools:

- Drill with bits: ⅛" (2mm)-dia. twist, #66 wire size
- Scroll saw blades: #0 or #2 spiral
- Palm sander (optional)

Additional patterns for the **FIERCE FELINES** are in the pullout section.



Charles Dearing lives in Gatesville, Texas and is the author of *Wildlife Portraits in Wood*, available at [www.foxchapelpublishing.com](http://www.foxchapelpublishing.com). Search for Charlie on Facebook to see more of his work or visit [woodenvisions.com](http://woodenvisions.com) to view over 1,000 patterns he has for sale.

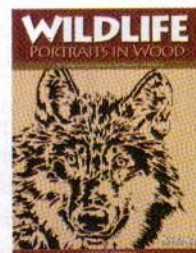





**Leopard portrait  
pattern**

© 2017 Scroll Saw Woodworking & Crafts

# Easy Salt & Pepper Shakers

Use scrap wood to make these functional dinner table decorations

By Gary MacKay

I designed these salt and pepper shakers when my wife mentioned she was tired of refilling our smaller pair. The oversized internal cavity, 1" (25mm) diameter by 2 3/4" (70mm) tall, gives you plenty of storage space. The filling hole is sized to accommodate standard 1/2" (13mm)-diameter corks. While the shakers I demonstrate are made from butternut and aspen, you can make the layers from whatever wood you have on hand.

## Getting Started

Cut the pieces to the dimensions in the Parts List. Draw diagonal lines from corner to corner on each blank to determine the center. Make four copies of the patterns.

## Stack Cutting

To stack cut, you secure several, usually thin, blanks together and cut them at the same time. This technique is often used to inlay one wood into another. There are several methods to secure the stack (see page 70), but I have found two that work well for me.

- Double-sided tape. There are many kinds, so I suggest you experiment to determine which one gives a secure hold but is easy to remove.
- Contact paper. Cover the two mating surfaces with contact paper. Then, apply spray adhesive to the contact paper and press the two pieces together. When you need to separate the stack, the contact paper peels right off the wood.



## MAKING THE SHAKERS

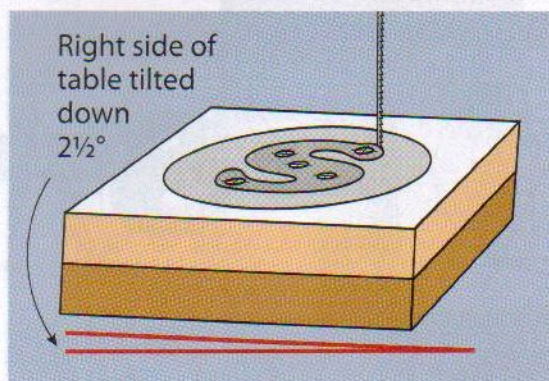

▲ **Step 1:** Stack together two inlay test blanks. Secure them (see Stack Cutting) and attach a copy of the S pattern to the stack. Tilt the right side of the saw table down 2 1/2°. Cut from the edge in along the top of the S, cutting in a counterclockwise direction as you cut the perimeter of the S. Separate the stack and place

the cut S from the top piece into the hole in the bottom piece. If it fits too loosely, increase the table tilt to 3°; if it fits too tightly, decrease the tilt to 2°. Recut the S until you get the proper fit.

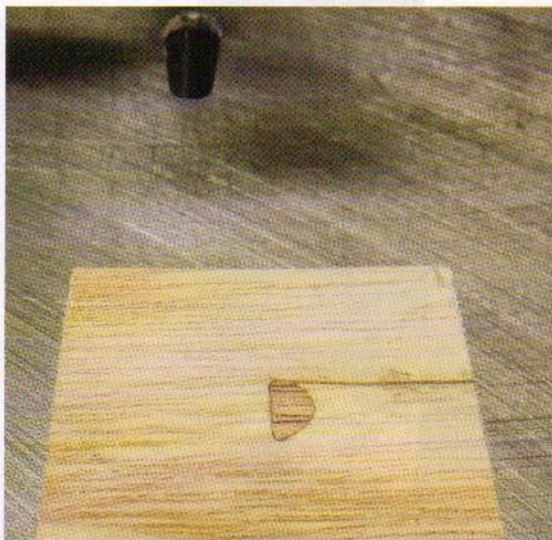

**▲ Step 2: Place the P inlay blank (A) on one top inlay blank (B) and secure the stacks.** Apply glue to the back of a P pattern, and use a pin to center the pattern on the stack. Cover the pattern with clear packaging tape. Leave the table tilted as you cut along the grain in from one side with a #5 blade to the center of the P. Then, cut in a counterclockwise direction around the center of the P. Separate the stack. Apply glue along the saw kerf in the inlay blank and the edges of the center of the P. Place the center of the P in position and tighten a clamp along the sides to force the saw kerf closed. Allow the glue to dry.

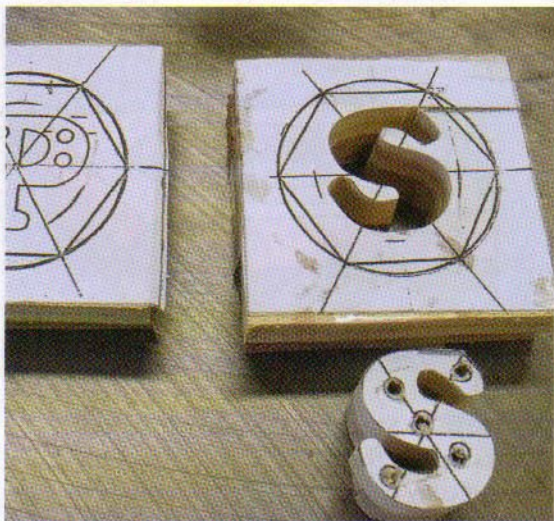

**▲ Step 3: Stack each top inlay blank (B) on the top blanks (C).** Secure the stack and apply adhesive to the back of the P and S patterns. Use a

pin to center the P pattern on the P center already glued into the top inlay. Center the S pattern on the other stack. Cover the patterns with clear packaging tape. Drill five 3/32" (2.5mm)-diameter holes where indicated. Then, cut in along the grain and cut the perimeters of the S and P in a counterclockwise direction. Use the process explained in Step 2 to glue the kerf shut and the inlays into the tops. Reset the scroll saw table to 0°.

**Step 4: Attach the ring patterns to the ring blanks (D, E, F, G, H).** Drill 1/8" (3mm)-diameter blade-entry holes and cut the center circles. (Or, use a 1", or 25mm, bit and drill the holes.) Remove the patterns from the ring 1 pieces only, and glue and clamp them underneath the tops.

**Step 5: Attach the base patterns to the base blanks (H).** Drill 1/8" (3mm)-diameter blade-entry holes and cut the small hexagon in each base. This will form a recess so the cork fits into the bottom of ring 5 without protruding.

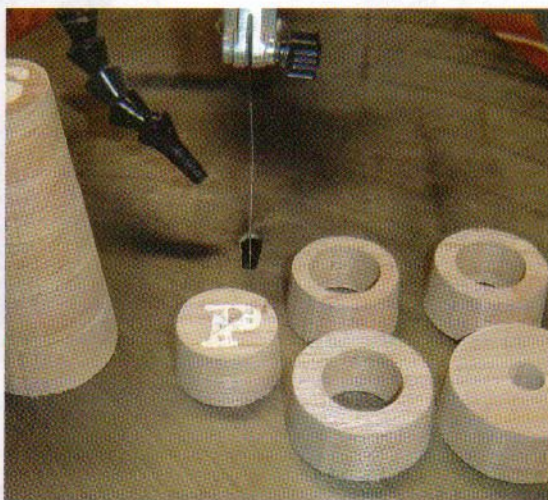

**▲ Step 6: Taper the pieces.** Tilt the right side of the scroll saw table down to 5° and switch to a #9 blade. Test-cut a piece of scrap wood to check the taper from the small top to the larger bottom. Then, cut all of the pieces along the perimeter lines to create a rough taper. Remove the patterns and sand off any fuzzies. Starting with the base (I), glue and clamp the layers on top of each other. Use a belt sander to smooth the outside profile. Hand-sand the top and bottom.

**Step 7: Apply a finish of your choice.** Make sure the inside is fully dry before adding salt and pepper and the cork stoppers. (You may need to trim the cork stoppers to the proper length.)

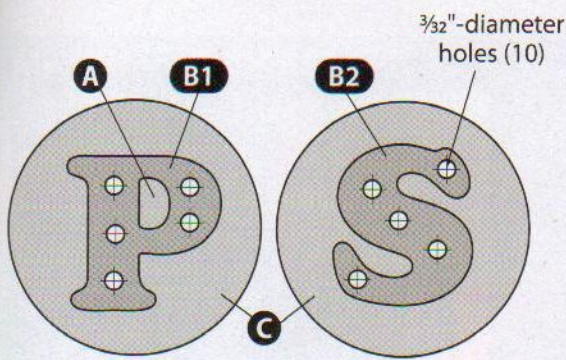

## Parts List

Item	Qty	Materials	Dimensions
<b>A</b>	1	Butternut, 1/4" (6mm) thick	1 3/4" x 1 3/4" (44mm x 44mm)
<b>B</b>	2	Aspen, 1/4" (6mm) thick	1 3/4" x 1 3/4" (44mm x 44mm)
<b>C</b>	2	Butternut, 1/4" (6mm) thick	1 3/4" x 1 3/4" (44mm x 44mm)
<b>D</b>	2	Butternut, 1/2" (13mm) thick	1 3/4" x 1 3/4" (44mm x 44mm)
<b>E</b>	2	Butternut, 3/4" (19mm) thick	2 1/4" x 2 1/4" (57mm x 57mm)
<b>F</b>	2	Butternut, 3/4" (19mm) thick	2 1/4" x 2 1/4" (57mm x 57mm)
<b>G</b>	2	Butternut, 3/4" (19mm) thick	2 1/4" x 2 1/4" (57mm x 57mm)
<b>H</b>	2	Butternut, 1/2" (13mm) thick	2 1/4" x 2 1/4" (57mm x 57mm)
<b>I</b>	2	Butternut, 1/4" (6mm) thick	2 1/4" x 2 1/4" (57mm x 57mm)

## Salt & pepper patterns

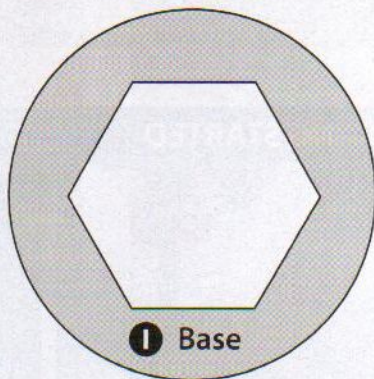
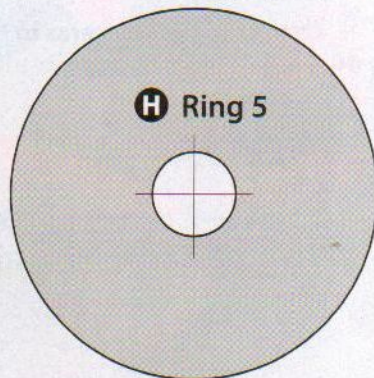
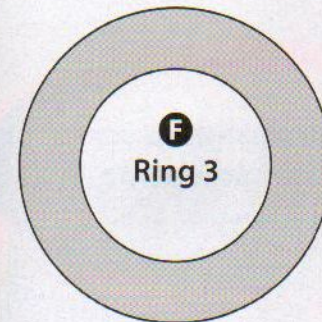
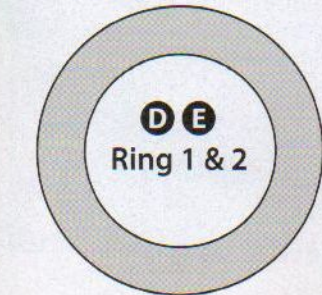

## Assembly diagram

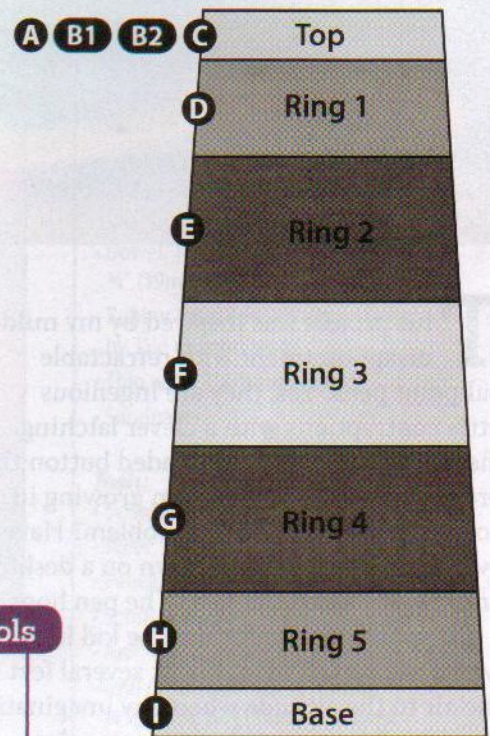

© 2016 Scroll Saw Woodworking & Crafts

## Materials & Tools

### Materials:

- Butternut, 1/4" (6mm) thick: 1 3/4" x 5 1/4" (44mm x 133mm); 2 1/4" x 4 1/2" (57mm x 114mm)
- Butternut, 1/2" (13mm) thick: 1 3/4" x 3 1/2" (44mm x 89mm); 2 1/4" x 4 1/2" (57mm x 114mm)
- Butternut, 3/4" (19mm) thick: 4 1/2" x 6 3/4" (114mm x 171mm)
- Aspen, 1/4" (6mm) thick: 1 3/4" x 3 1/2" (44mm x 89mm)
- Scrap wood, 1/4" (6mm) thick: inlay test cuts, 2 each 2" x 6" (51mm x 152mm)
- Cork stopper, 1/2" (13mm) dia.: 2 each 3/4" (19mm) long
- Glue stick
- Double-sided tape OR spray adhesive and contact paper
- Wood glue
- Sandpaper
- Pin
- Finish: clear spray

### Tools:

- Scroll saw blades: #5 reverse-tooth, #9 reverse-tooth
- Drill with bits: twist, 3/32" (2.5mm), 1/8" (3mm) dia.; forstner, 1" (25mm) dia. (optional)
- Belt sander
- Clamps

The author used these products for the project. Substitute your choice of brands, tools, and materials as desired.



Gary MacKay of Myrtle Beach, S.C., is the author of Box-Making Projects for the Scroll Saw, available from Fox Chapel Publishing at [www.foxchapelpublishing.com](http://www.foxchapelpublishing.com).

# Desktop Rockets



**T**his project was inspired by my mild disappointment with retractable ballpoint pens. Yes, they are ingenious little contraptions with a clever latching mechanism and a spring-loaded button that prevents large ink spots from growing in your pocket, so what's the problem? Have you ever pushed that button down on a desktop and then released the pen? The pen hops a disappointing inch or so. The kid in me wants the pen to soar at least several feet in the air to the altitude where my imagination can turn it into something spectacular. So that's what I set out to accomplish—a desktop rocket that would gain some serious altitude and ignite a kid's imagination.

**WARNING:** Before launching the rocket, be sure there is nothing above it, such as a fluorescent light, ceiling fan, satellite, or (more importantly) any part of you!

## GETTING STARTED

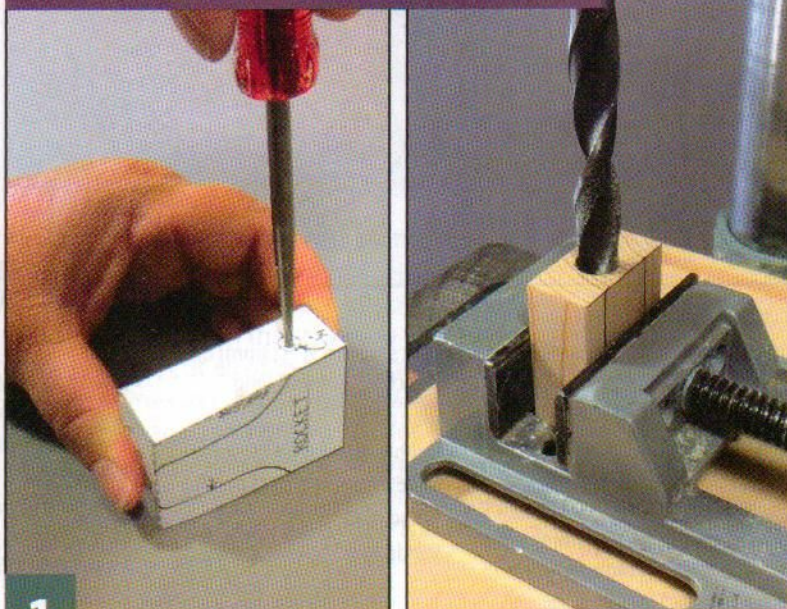

1

**Prep the wood.** Cut the rocket body blank, the fuel rod, and pins to size. The grain should run lengthwise down the rocket body. Fold the rocket body pattern on the dotted lines and attach it to the blank. Use an awl to mark locations for two holes. Drill the indicated holes in the rocket body and fuel rod. Use a clamp and a drill press to drill a hole for the fuel rod.

## MAKING THE ROCKET

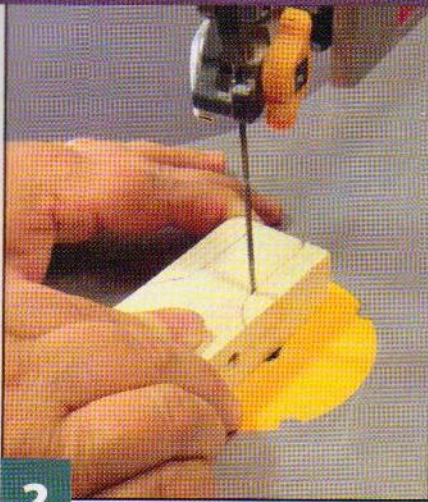

**2** **Cut the rocket body to shape.**  
Use a scroll saw.

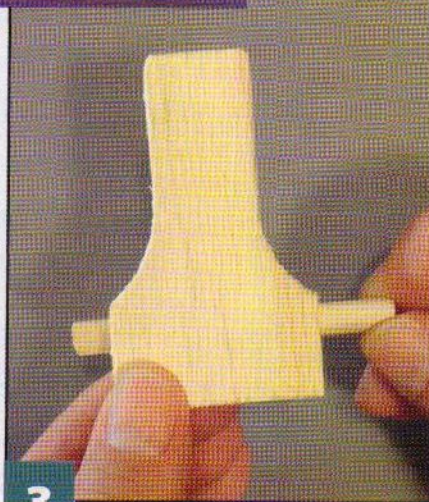

**3** **Insert the pins into the holes in the rocket body.** Glue them in place with about  $\frac{1}{4}$ " (6mm) protruding from the sides, making sure that neither pin is visible in the hole for the fuel rod.

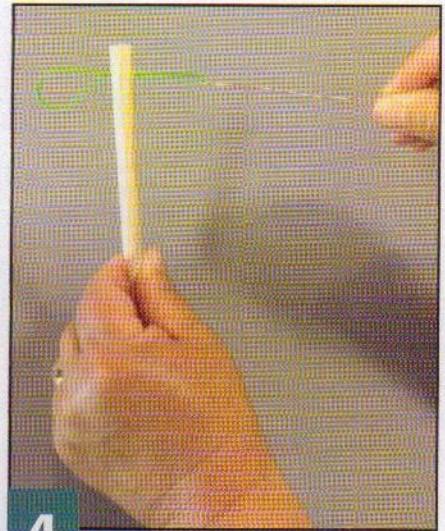

**4** **Pull a rubber band through the hole in the fuel rod.** I use a thin wire. Make sure there are equal lengths of rubber band on either side of the fuel rod.

## LAUNCHING THE ROCKET

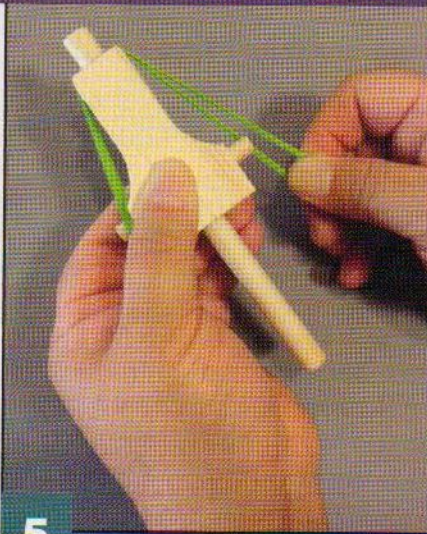

**5** **Place the fuel rod into the hole in the rocket body.** Make sure the end with the rubber band is at the narrow top of the body. Loop each side of the rubber band around a pin on either side.

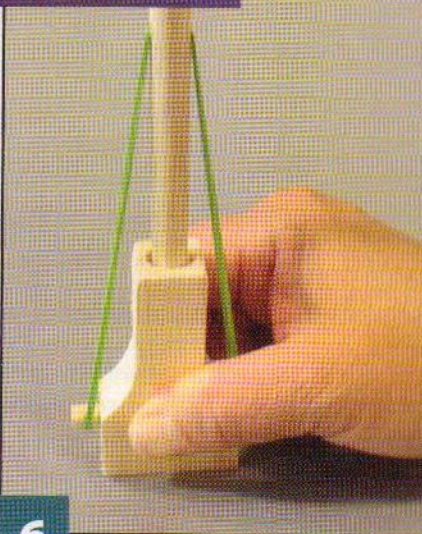

**6** **Launch the rocket by pinching both sides of the body between your thumb and forefinger.** Place the end of the fuel rod on the table and press down on the rocket body until the base of the body is flat on the table surface. Release your fingers and watch your rocket soar. For a higher launch try licking your fingers. After testing the rocket, sand, shape, and decorate it in a variety of ways.

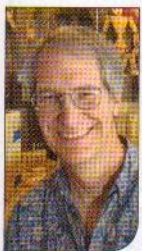

*Bob Gilsdorf lives in Colorado Springs, Colo., with his wife and five sons. Bob started woodworking at a young age, and he has built wooden toys for most of his life. An engineering manager at a semiconductor company, Bob*

*continues to invent and make wooden toys. He has written two books, Zany Wooden Toys and Zany Wooden Toys Reloaded.*

## Materials & Tools

### Materials:

- Pine,  $\frac{3}{4}$ " (19mm) thick: rocket body,  $1\frac{1}{2}$ " x  $2\frac{1}{2}$ " (38mm x 64mm)
- Dowel,  $\frac{3}{8}$ " (10mm) dia.: fuel rod,  $5\frac{1}{2}$ " (140mm) long
- Dowel,  $\frac{1}{4}$ " (6mm) dia.: pins, 2 each  $\frac{3}{4}$ " (19mm) long
- Rubber band #64:  $\frac{1}{4}$ " (6mm) wide by  $3\frac{1}{2}$ " (89mm) long
- Thin wire: 3" (76mm) long
- Sandpaper

### Tools:

- Scissors
- Ruler
- Pencil
- Scroll saw blades: #5 reverse-tooth
- Awl
- Drill press with bits:  $\frac{1}{8}$ " (3mm),  $\frac{1}{4}$ " (6mm),  $\frac{1}{2}$ " (13mm)-dia. twist
- Clamp

The author used these products for the project. Substitute your choice of brands, tools, and materials as desired.

Patterns for the **DESKTOP ROCKET** are in the pattern pullout section.

Send us pictures of your finished and decorated rockets. Bob might choose your idea to share in his upcoming book!

E-mail #rockets to: [editors@scrollsawer.com](mailto:editors@scrollsawer.com).

# Kitty Basket

Cute intarsia design introduces a simple way to create a basket-weave effect

By Kathy Wise



**N**othing is cuter than a basket full of kittens. Not only is this project a great gift for a cat lover, it's a welcome gift for almost anyone. Below are the basic steps to create an intarsia, but this article will focus on making the basket. While the basket looks complex, it's really just a few cutting steps. For an easier and faster project that requires less fitting of pieces together, you can cut each kitten from a solid color of wood and leave off the basket handle.

## Getting Started

The basic steps for intarsia projects are very similar. Make several copies of the pattern, keeping one as a master. Cut around each pattern piece and sort them into groups by wood color. Spray adhesive onto the backs of the pattern pieces; attach them to the shiny side of clear shelf paper, such as Con-Tact® brand; trim the patterns; and stick them onto the wood. Wood color suggestions are listed on the pattern, and

wood selections are in the Materials list. Place pieces of wood next to each other to help you decide upon the color combinations; don't feel restricted to the colors and woods I used. Use different thicknesses of wood for the basket to reduce the amount of sanding required. Cut the wooden pieces, mark the pattern number on the bottom of each with a pencil, and add risers as needed.

## Sanding and Shaping Overview

Use the shaping guide to mark the sanding levels. Remove the majority of the wood with a 100-grit sanding drum, and use a 220-grit drum to soften the edges and remove scratches from the coarse grit. Hold small pieces with pliers and wear finger protection when sanding. Start with the highest pieces, and always keep your sand-to-line in sight. Use a rotary tool or an oscillating spindle sander in tight areas, and buff the pieces with a sanding mop.

## BASKET: CUTTING THE PIECES

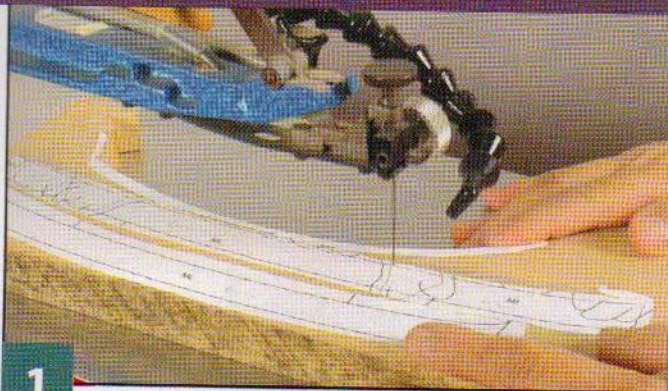

**1** **Cut the basket handle, top, and bottom rims.** Use  $\frac{3}{4}$ " (19mm)-thick wood. Cut the top part of the basket along the dotted lines. You will fit the paws to the top of the basket after you sand and shape the kittens.

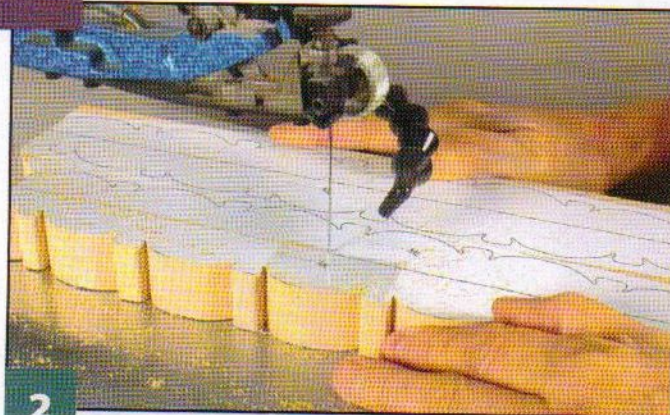

**2** **Stack together two  $\frac{1}{2}$ " (13mm)-thick basket-weave blanks.** Use double-sided carpet tape. Attach two basket-weave patterns side by side to the top and cut the basket weave patterns. You should finish with eight pieces.

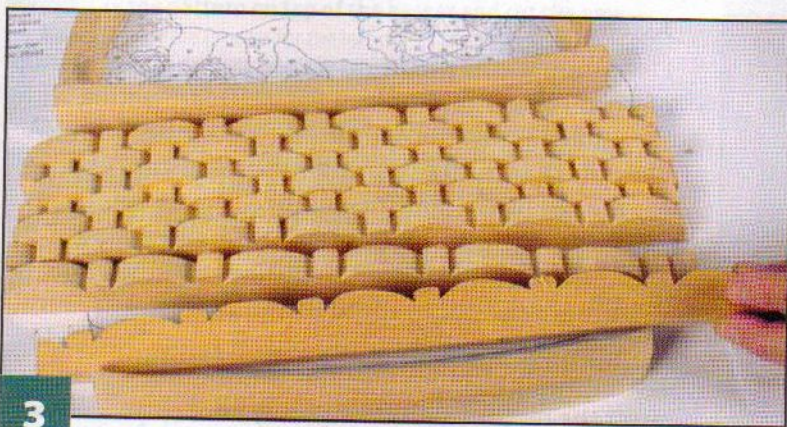

**3** **Interchange the pieces to create the basket-weave pattern as shown.** Number the bottom of each piece from one to eight so you can return them to the correct order after sanding. Secure the pieces in order with clear packaging tape. Cover the front and back of the pieces with clear packaging tape, making sure to keep the pieces flat on the bottom.

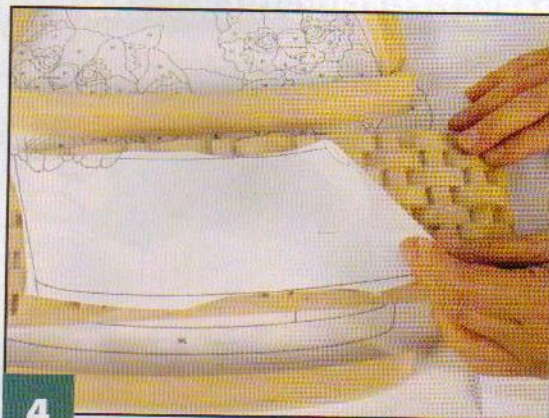

**4** **Align the pieces.** Align the middle of the basket bottom pattern with the bottom of the first line of basket weave and press it into place. The tape on the blanks helps keep the pattern flat while you cut.

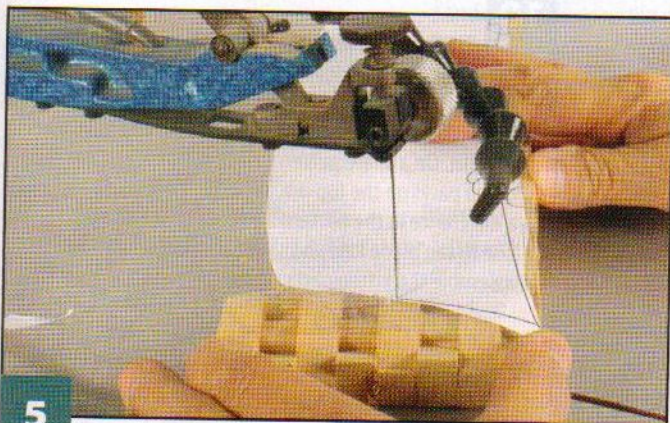

**5** **Cut the basket.** Do not cut the paw overlap areas yet, as they will be fitted on top later after the kittens are sanded and glued together. Remove the tape.

## BASKET: SHAPING THE WEAVE

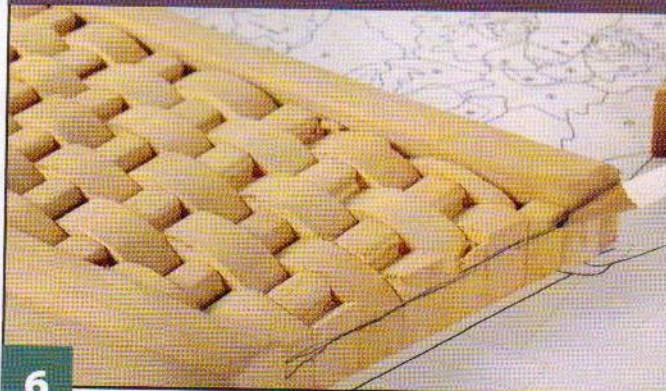

**6** **Mark the final thickness on the edges of the basket.** Taper the edges of the basket to this line using a pneumatic drum sander. Round the edges of the top and bottom rims with the same tool.

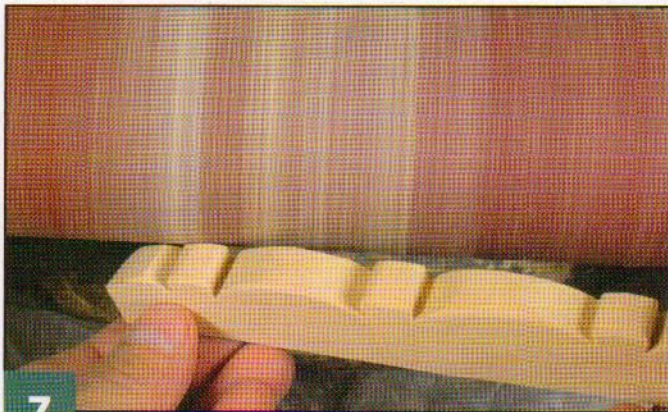

7

**Round the edges and ends of the basket-weave pieces.** Use the drum sander. Then, round the handle pieces. Buff the pieces with a sanding mop. The sanding mop reduces your sanding time substantially.



8

**Glue together the basket-weave pieces, and the top and bottom rim.** Use cyanoacrylate (CA) glue. You can also use CA glue accelerator to speed up the gluing process. Use a portable drum sander, such as a Sand-Flee, to flatten the bottom of the glued-together section.

## BASKET: SHAPING THE KITTENS



9

**Sand and shape the kitten pieces.** Leave the paws unsanded until they are fitted to the top rim of the basket.

## Assembling the Project

Dry-assemble the pieces on waxed paper placed on top of a copy of the pattern on a flat surface. Starting with the middle kitten, secure the pieces together with CA glue. Make sure all of the adjoining pieces are in place next to the pieces you are gluing to keep things from shifting out of place. Place dots of CA glue between each piece and quickly put them back together. You can use accelerator to speed up the process, but make sure you get the pieces in the proper positions quickly. Do not apply so much glue that it oozes out when you press the pieces together. You may have to make some adjustments when joining the kittens to each other. If you carefully recut along the line between the two sections, you can often draw them closer together.



10

**Fit the kittens to the top rim of the basket.**

Sand or recut any edges that don't allow the kittens to fit tightly to the basket. Fit the paws in place on the basket without the risers. Make sure you have a tight fit. On a spare pattern, trace the new outline of the paws on the top rim pattern. There is usually a difference in the pattern and your glued kittens due to the blade kerf and slight shifting when you assemble the kitten parts.

## BASKET: COMPLETING THE PROJECT



11

**Lay the pattern on top of the basket and cut the new lines.** Repeat the process for the left side of the basket handle. Fit the paws to the top rim of the basket. Then, shape the paws and buff them with the sanding mop. Glue all of the pieces together with CA glue, and flatten the bottom with the drum sander. Trace the assembled project onto the backing board and cut it out. Apply dots of CA glue and wood glue to the back of the intarsia and apply accelerator to the backing board. Press the two together and trim off any overhanging backing board.



12

**Apply finish to the pieces.** I use clear satin spray finish, but you can use a finish of your choice. Follow the manufacturer's instructions and allow the finish to dry overnight. Attach a hanger to the back.

### Materials & Tools

#### Materials:

- Medium light wood, such as basswood,  $\frac{3}{4}$ " (19mm) thick: basket rims, handle, 6" x 36" (152mm x 914mm)
- Medium light wood, such as basswood,  $\frac{1}{2}$ " (13mm) thick: basket weave: 6" x 18" (152mm x 457mm)
- White wood, such as maple, 1" (25mm) thick: kittens, 8" x 12" (203mm x 305mm)
- Yellow wood, such as yellowheart,  $\frac{3}{4}$ " (19mm) thick: eyes, 1" (25mm) square
- Medium wood, such as cherry, 1" (25mm) thick: calico cat, 6" x 8" (152mm x 203mm)
- Medium dark wood, such as black walnut, 1" (25mm) thick: calico cat, 4" x 5" (102mm x 127mm)
- Dark wood, such as wenge, 1" (25mm) thick: 6" x 8" (152mm x 203mm)
- Black wood, such as ebony,  $\frac{1}{2}$ " (13mm) thick: 2" x 3" (51mm x 76mm)
- Tempered hardboard,  $\frac{1}{8}$ " (3mm) thick: 15" x 18" (381mm x 457mm)
- Clear shelf paper, such as Con-Tact®
- Tape: double-sided carpet, clear packaging
- Spray adhesive
- Glue: wood, cyanoacrylate (CA) glue with accelerator (optional)
- Sanding drums: assorted grits
- Finish: clear satin polyurethane varnish
- Waxed paper
- Hanger

#### Tools:

- Scroll saw blades: #3, #5, or #7 skip-tooth
- Sanders: pneumatic drum, portable drum, sanding mop, oscillating spindle
- Rotary tool with sanding drums and carving bits

*The author used these products for the project. Substitute your choice of brands, tools, and materials as desired.*

Pattern for the **KITTY BASKET** is in the pattern pullout section.



Kitten on Rope #414



*Kathy Wise is a nationally acclaimed intarsia artist. She has written consecutive articles for Scroll Saw Woodworking & Crafts for the past 12 years, including 48 articles for regular issues and additional patterns for a variety of special issues. Kathy has also written three books. For a free catalog of 500 patterns, contact Kathy*

*Wise Designs Inc., P.O. Box 60, Yale, Mich. 48097, fax 810-387-9044, [www.kathywise.com](http://www.kathywise.com), [kathywise@bignet.net](mailto:kathywise@bignet.net).*

# Spring Round-up

Inspiration for a bright new season

By Kathleen Ryan

1



2

## 1 Wooden Mandala

Jeannette Aragon of Chatsworth, Calif., created this 4' mandala for a retreat center. She drew the design directly onto the wood, cut chunks with a jigsaw, and used a scroll saw to create smaller puzzle pieces. Each puzzle piece has a Scripture quote on the back. Participants take a piece and meditate on the Scripture overnight, and then reassemble the mandala in the morning. *See more of Jeannette's work at [www.puzzled1.com](http://www.puzzled1.com).*

## 2 Sleepy Baby Fox

This shelf sitter was designed and crafted by Tammi Thomas of WoodlandCritters in Stroudsburg, Pa. Tammi cut the 7½" by 15" design from pine and painted it with acrylics. *View more of Tammi's work at [www.etsy.com/shop/woodlandcritters](http://www.etsy.com/shop/woodlandcritters).*



3

## 3 Penguin Love Card

Yvonne Leung of Cardtorial in Hawthorne, Calif., designed and laser cut this wooden greeting card in certified sustainable alder wood. The card measures 4" by 6", leaving plenty of room for a personal message. *Visit Yvonne at [www.cardtorial.com](http://www.cardtorial.com).*

## 4 Bunny Napkin Rings

Sheila Landry of Meteghan, N.S., Canada, designed and handcrafted these bunny napkin rings to dress up the Easter table. She cut the 2¾"-tall bunnies from MDF, sanded them, and painted them with acrylics. *View more of Sheila's work at [www.sheilalandrydesigns.com](http://www.sheilalandrydesigns.com).*

*Note: These projects are intended as inspiration only. The patterns are not in this issue, nor are they necessarily available from the designers.*

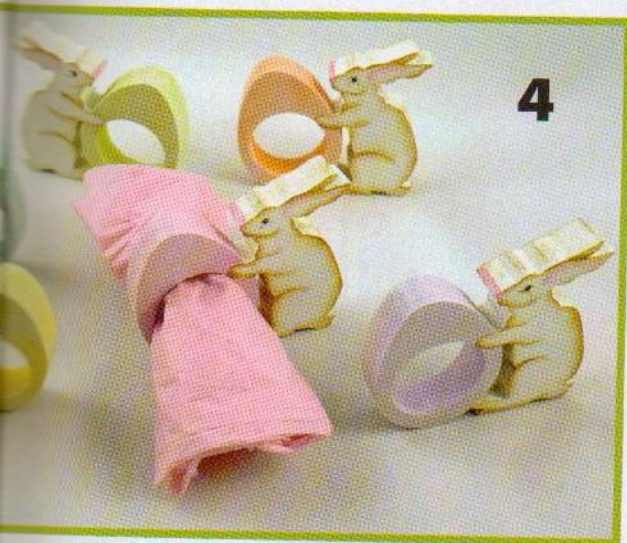

4



5



6



7



8

### 5 Wooden Cross Necklace

Handcrafted from African pink ivory wood, this cross was designed and cut by Mike Beaulieu of Mountain Home, Idaho. The piece measures  $\frac{5}{8}$ " by  $1\frac{3}{8}$ " and is made of naturally colored wood coated with lacquer. See more of Mike's work at [www.thelotusshop.etsy.com](http://www.thelotusshop.etsy.com).

### 6 Exotic Wooden Tray

This serving tray, designed and crafted by Ronald Frank of Madisonville, Tenn., makes an excellent Valentine's Day gift. Crafted from teak and African mahogany veneer plywood, the multipurpose tray measures  $11\frac{1}{2}$ " by 20". Visit Ron at [etsy.com/shop/lightlyseasoned](http://etsy.com/shop/lightlyseasoned).

### 7 Rosh Hashanah Serving Set

Anat Stein and Hadas Kruk of Tel Aviv, Israel, were inspired by Israeli symbols of the pomegranate and honeycomb when they designed this wooden tray with six puzzle-like removable coasters. The set is made of poplar plywood with walnut and oak veneers and coated with food-safe linseed oil. See more of Anat and Hadas's work at [www.studioarmadillo.com](http://www.studioarmadillo.com).

### 8 Love Bookends

Alec and Alissa Smidt of Traverse City, Mich., created these bookends, 4" by 8", for St. Patrick's Day. The pair used cedar boards that they glued, cut, sanded, and sprayed with latex paint. They applied silicon to the base to prevent sliding. See more of Alec and Alissa's work at [wanderlustbyalissa.etsy.com](http://wanderlustbyalissa.etsy.com).

# Hamsa Box

Combine colorful veneer and hardwoods to make a meaningful gift

By Carole Rothman



**T**he hand-shaped hamsa symbol is believed to bring luck, good health, and protection from the forces of evil. It has a special place in Judaism and is also a sacred and respected symbol in Christianity, Islam, Hinduism, and Buddhism.

Although the hamsa is usually worn as a pendant, I incorporated it into a box for a friend down on her luck. I used brightly colored veneer to symbolize my wishes for happier days ahead and was pleased when my gift was received in the spirit intended.

## BOX: VENEERING THE LID

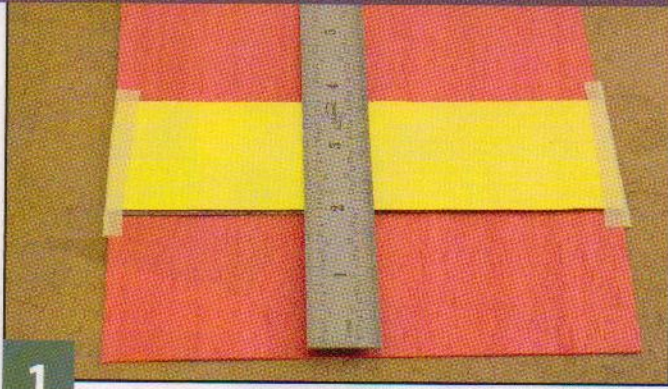

**1** Position one piece of red veneer with the grain running vertically. On each long side, make a small pencil mark 2" (51mm) up from the bottom edge. Place the red veneer on a larger piece of thin cardboard, matching the edges. Place the strips of yellow and purple veneer across the red veneer with their lower edges at the 2" (51mm) mark. Attach these strips at the short ends to the red veneer and cardboard using masking tape.

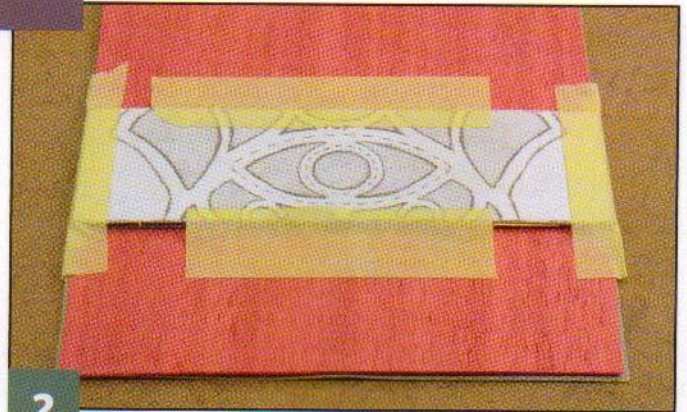

**2** Cut along the two horizontal dotted lines of the lid pattern to access the eye pattern. Using a glue stick, attach the pattern to the smaller piece of cardboard. Place the pattern and cardboard, top edge up, across the purple and yellow veneer, and secure it with masking tape at the top, side, and bottom edges.

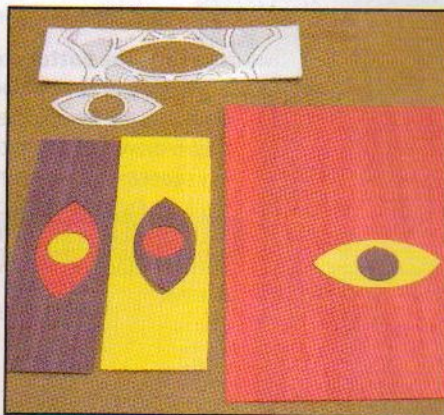
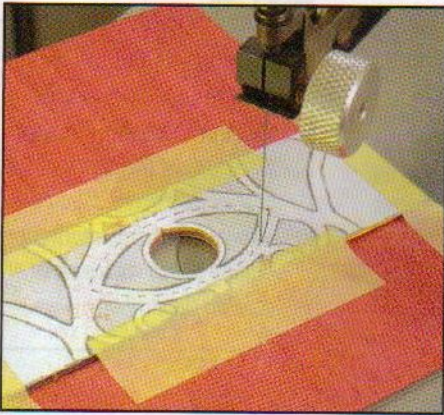

**3** Drill a small blade-entry hole on the dotted cutting line of the circle. Insert a #2/0 blade through the hole and cut around the circle. Carefully remove the pieces. Repeat for the eye-shaped dotted cutting line. Separate all of the pieces and place the eye-shaped yellow piece and the round purple piece into position on the red veneer. The remaining pieces of veneer can be used for another project.

## BOX: COMPLETING THE LID



**4** Tape the eye pieces into position on the red veneer. Use veneer tape or masking tape on the upper surfaces. Glue this assembly to the top face of the lid and glue the remaining piece of red veneer to the bottom face. Use a veneer roller on each side to get a good bond. Clamp the pieces securely and let the assembly dry. Carefully remove the tape from the eye area. Sand the surfaces carefully to even the grain, removing sanding dust with a vacuum or damp paper towel. Be careful to keep red veneer dust off the yellow veneer.

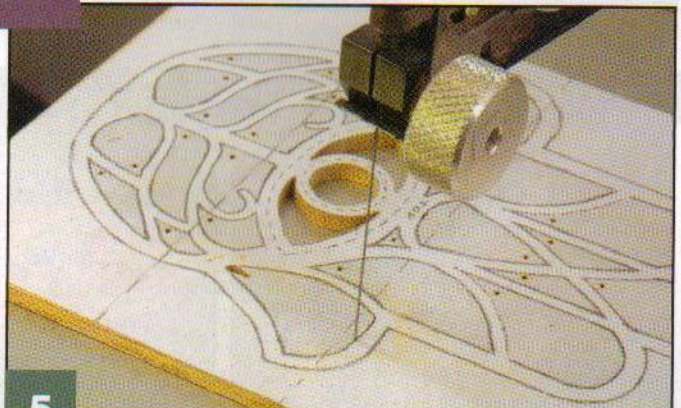

**5** Attach the lid pattern to the top fretwork blank. Use repositionable adhesive. Drill blade-entry holes in the internal areas and cut the frets using a #1 blade. Remove the internal parts of the pattern (on the bridges between the frets) so you can see and correct any irregularities and blade marks, but keep the perimeter of the pattern intact. Carefully sand the exposed fretwork bridges smooth.

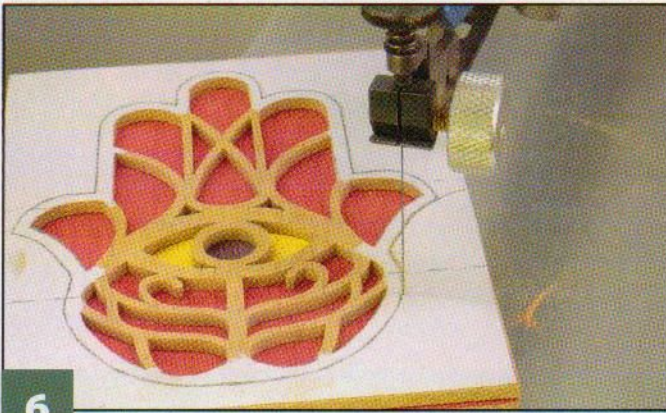

6

**Glue the fretwork to the veneered lid.** Make sure the joints between the pieces of veneer are covered by the fretwork. To minimize squeeze-out, apply glue only to the wider areas of the perimeter and eye. Clamp and let it dry for five minutes. Remove the clamps and carefully remove any squeeze-out, re-clamp, and let dry fully. Cut along the perimeter of the lid pattern with a #3 blade, cutting to the outside of the line.

## BOX: MAKING THE BODY

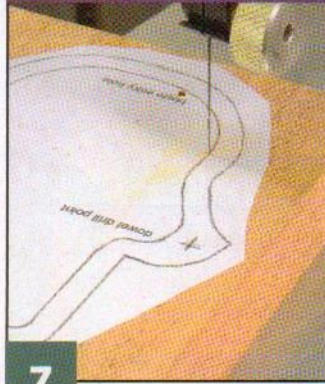

7

**Attach the box body pattern to the body blank.** Mark the drilling points for the dowels with an awl. Drill a blade-entry hole where indicated and cut the box interior with a #7 blade. Do not remove the pattern. Sand the inside smooth using a spindle sander. Remove any fuzzies from the lower edge.

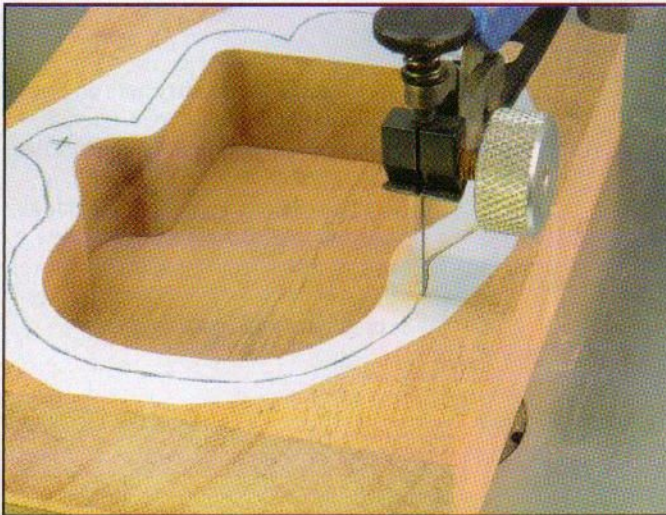
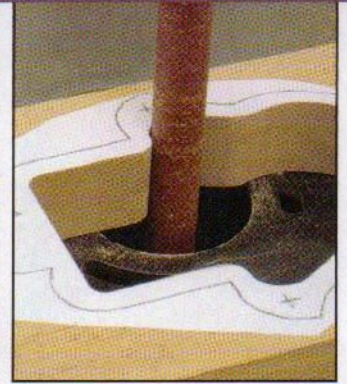

8

**Glue the bottom to the underside of the box body.** Clamp, let dry five minutes, and then remove the clamps to remove any squeeze-out. Re-clamp and let dry fully. Cut around the perimeter with a #7 blade, cutting to the outside of the line. Remove the pattern.

### TIP

#### DRILLING DEPTH

*If you are using a drill press, mark the box body and lid at the desired depths. For each piece, adjust the depth of the hole as instructed. If you are using a hand drill, mark the drilling depth with a piece of tape on the drill bit.*

## BOX: COMPLETING THE PROJECT

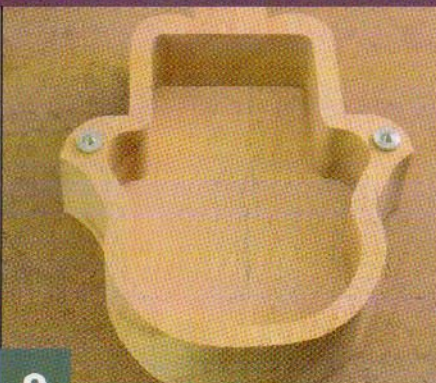

9

**Drill holes for the lid dowels in the box body.** Use a  $\frac{1}{4}$ " (6mm)-diameter bit to drill two  $\frac{1}{2}$ " (13mm)-deep holes where marked on the box body. Insert a  $\frac{1}{4}$ " (6mm) dowel center into each hole. Place the lid on top, carefully aligning it with the box body. Press down gently on the lid to mark the drilling points in the lid. Use the same bit to drill  $\frac{3}{16}$ " (5mm)-deep holes at the marked points, being careful not to drill through the lid.

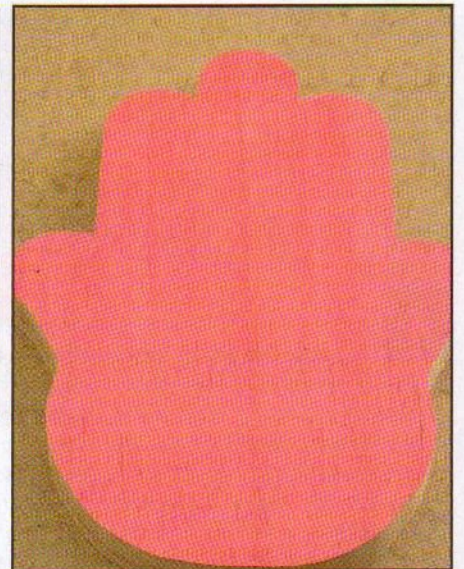
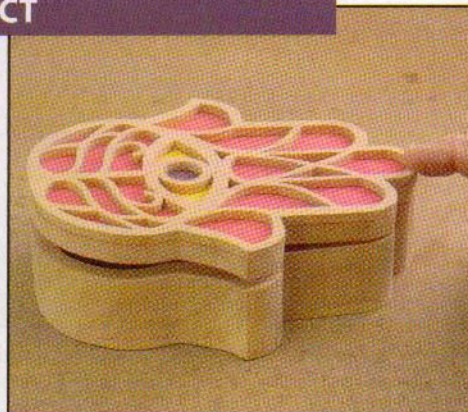

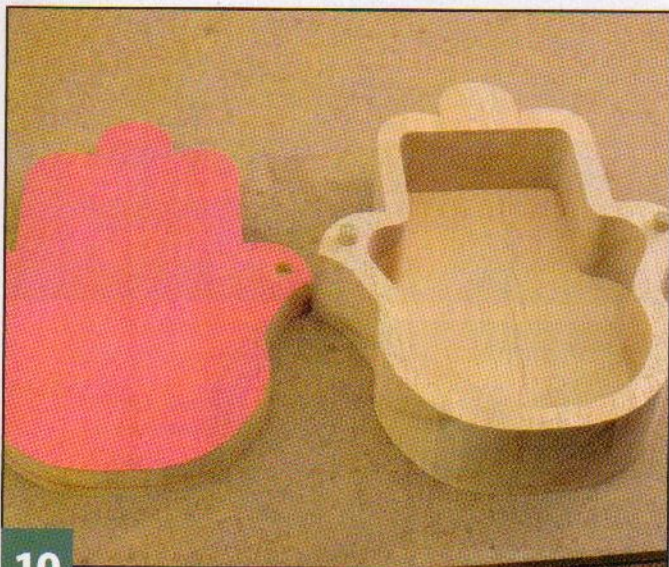

10

**Insert the dowel pieces into the holes in the base.** Sand them until they fit easily but snugly. Round the top edges of the dowels and place the lid on top to check the fit. Adjust the length of the dowels until the lid sits flat on the box body. Remove the dowels, apply a light coat of glue, and seat them into the holes in the body using a wooden mallet if needed.

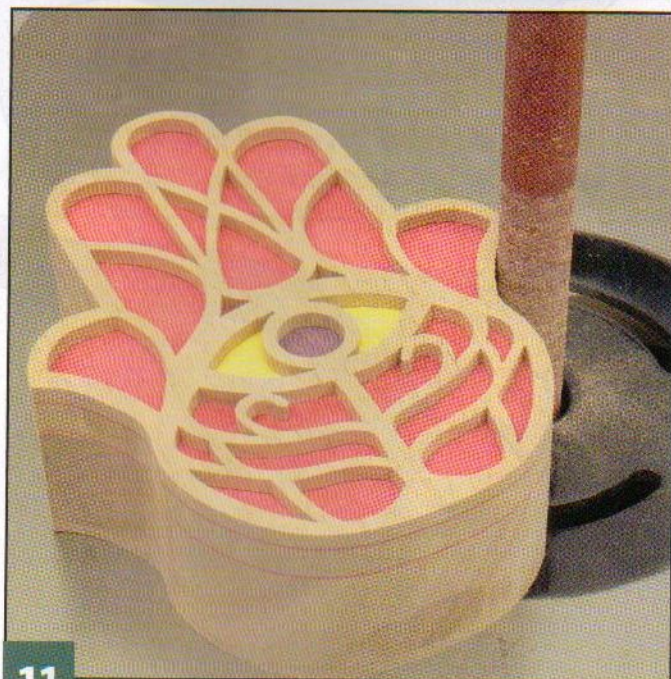
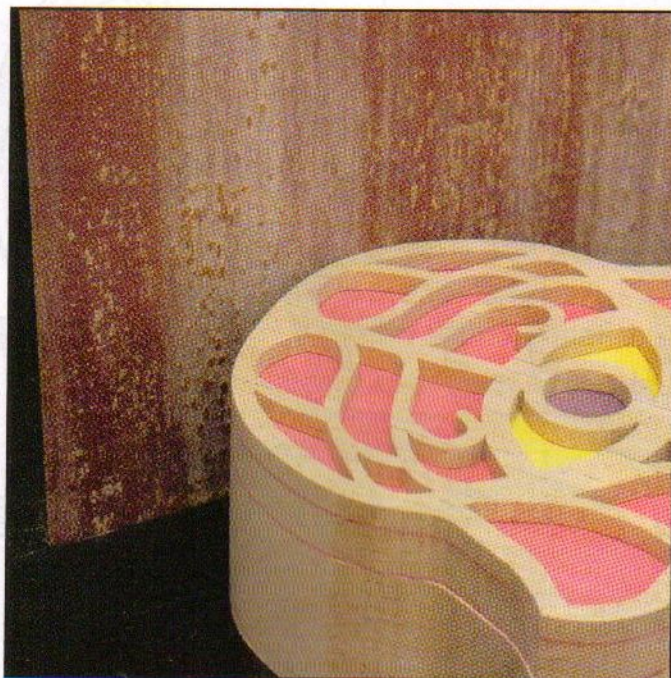

11

**Place the lid on the box body.** Sand the completed box as one piece until the sides are smooth and the lid and box body are evenly matched. You can use a belt sander for the rounded lower edge and a spindle sander for the curved areas. Use a sanding block for the hard-to-reach areas, and soften the upper edges by hand. Sand all of the surfaces up to 220 grit. Remove all of the sanding dust, using a vacuum for the recessed areas. Finish with several coats of spray shellac or lacquer, rubbing between coats with 0000 steel wool as needed.

## Materials & Tools

### Materials:

- Mahogany, 1 $\frac{1}{8}$ " (29mm) thick: box body, 5 $\frac{1}{2}$ " x 7" (140mm x 178mm)
- Mahogany,  $\frac{5}{16}$ " (8mm) thick: lid, 5 $\frac{1}{2}$ " x 7" (140mm x 178mm)
- Mahogany,  $\frac{1}{8}$ " (3mm) thick: box bottom, 5 $\frac{1}{2}$ " x 7" (140mm x 178mm)
- Mahogany,  $\frac{3}{16}$ " (5mm) thick: lid fretwork, 5 $\frac{1}{2}$ " x 7" (140mm x 178mm)
- Red veneer: 2 each, 5 $\frac{1}{2}$ " x 7" (140mm x 178mm)
- Yellow veneer: 1 $\frac{3}{4}$ " x 5 $\frac{1}{2}$ " (44mm x 140mm)
- Purple veneer: 1 $\frac{3}{4}$ " x 5 $\frac{1}{2}$ " (44mm x 140mm)
- Hardwood dowel,  $\frac{1}{4}$ " (6mm) dia.: 2 each, 1 $\frac{1}{16}$ " (18mm) long
- Thin cardboard: 1 $\frac{3}{4}$ " x 5 $\frac{1}{2}$ " (44mm x 140mm), 5 $\frac{1}{2}$ " x 7" (140mm x 178mm)
- Tape: masking, veneer (optional)
- Wood glue, Weldbond preferred
- Glue stick
- Repositionable adhesive
- Sandpaper, assorted grits
- Finish: spray shellac or spray lacquer
- Steel wool: 0000

### Tools:

- Drill press with bits: #60 wire size or smaller,  $\frac{1}{4}$ " (6mm) dia., brad point preferred
- Scroll saw blades, #2/0, #1, #3, #7
- Sanders: spindle, belt
- Awl
- Dowel centers: 2 each,  $\frac{1}{4}$ " (6mm) dia.
- Veneer roller
- Clamps
- Wooden mallet
- Awl

*The author used these products for the project. Substitute your choice of brands, tools, and materials as desired.*

## Hamsa box patterns

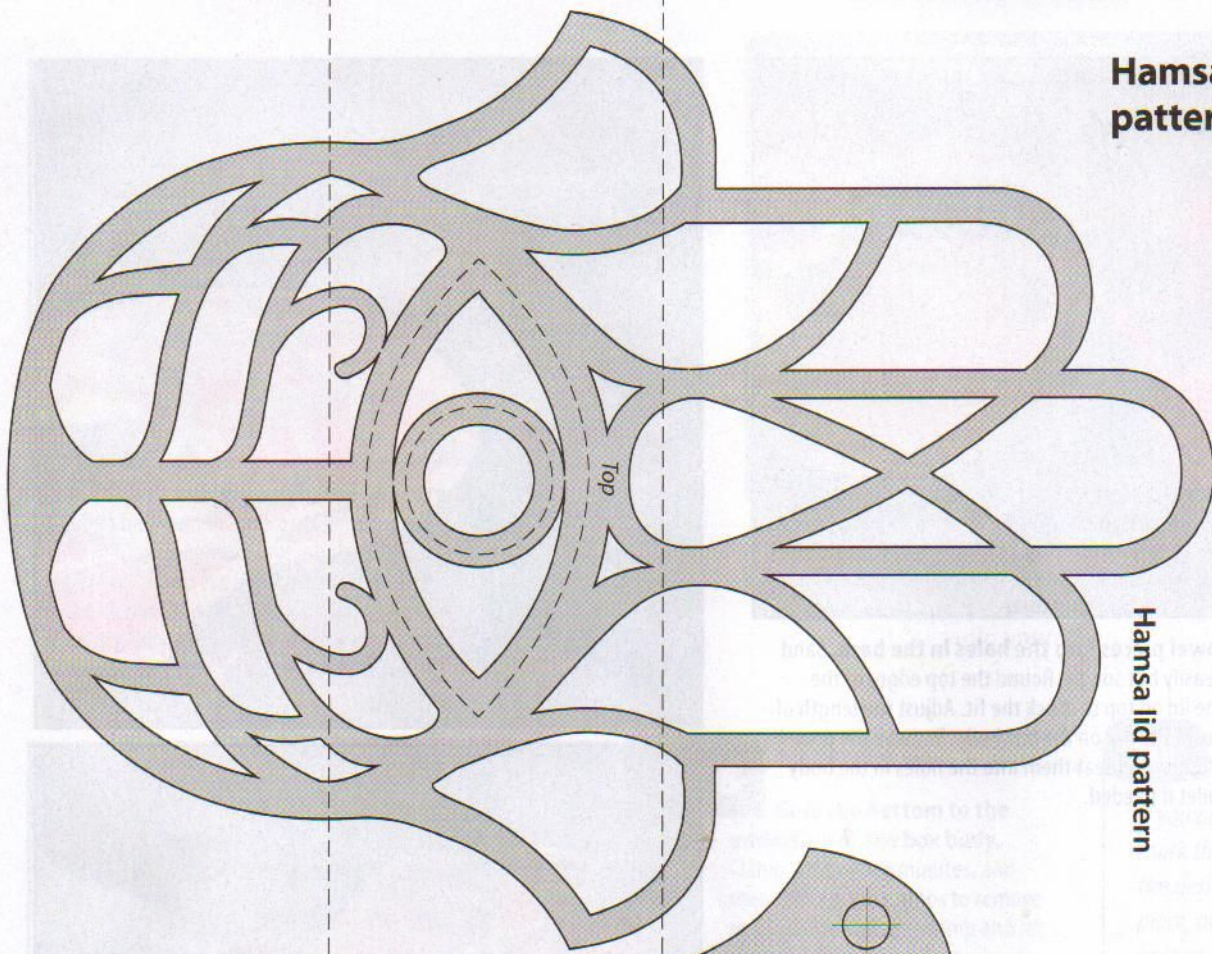

Hamsa lid pattern

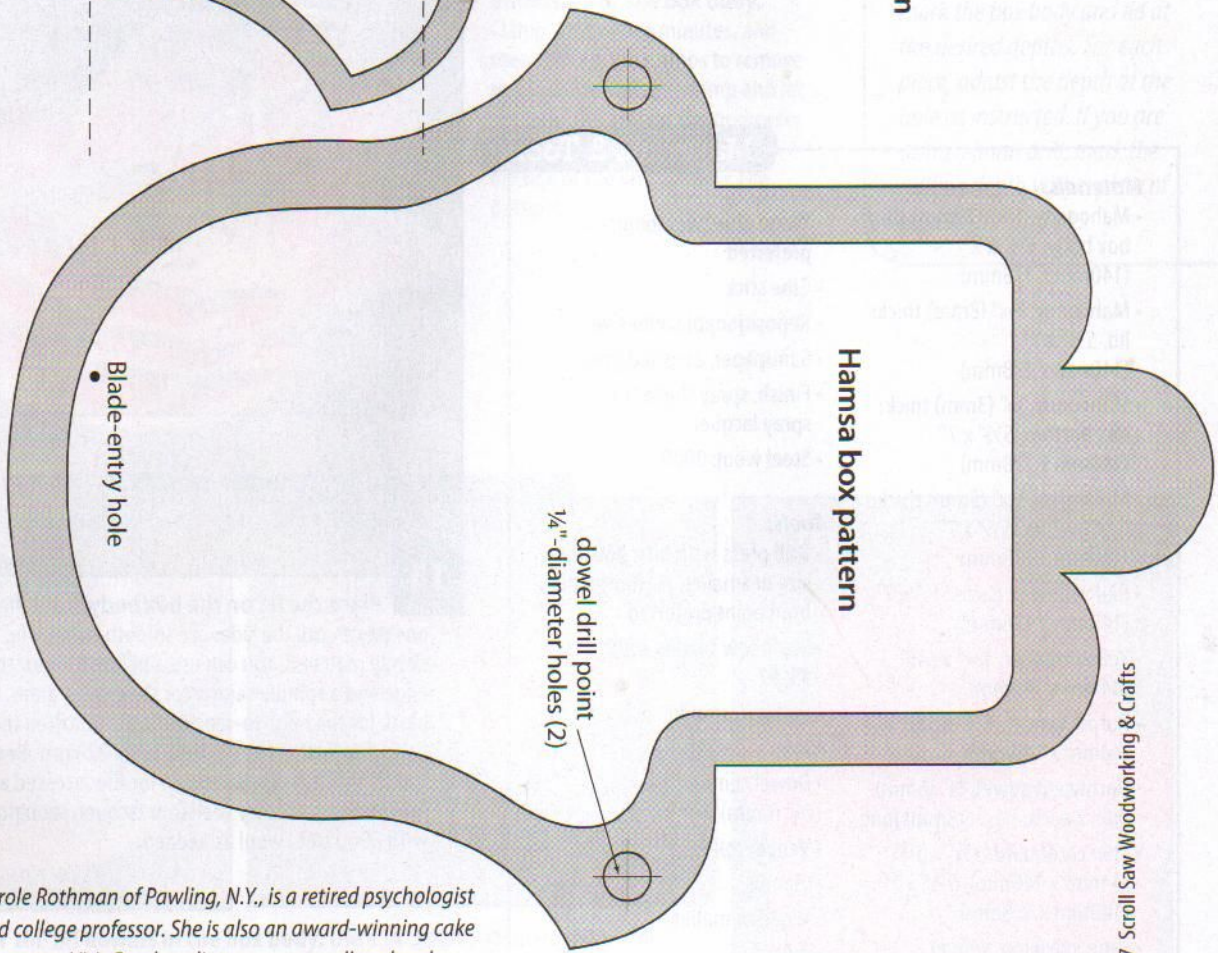

Hamsa box pattern



Carole Rothman of Pawling, N.Y., is a retired psychologist and college professor. She is also an award-winning cake decorator. Visit Carole online at [www.scrollsawbowls.blogspot.com](http://www.scrollsawbowls.blogspot.com). You'll find her books *Creative Wooden Boxes* from the *Scroll Saw and Wooden Bowls* from the *Scroll Saw* at [www.foxchapelpublishing.com](http://www.foxchapelpublishing.com).

## Kiln-Dried, Premium, Domestic Hardwood for Flooring, Furniture & more!

Groff and Groff Lumber is a specialty company with a large supply of kiln-dried, premium domestic hardwoods which include:

- Black walnut (unsteamed)
- Cherry
- Maple
- Butternut
- Oaks
- Paulownia
- Ash
- Beech
- Sassafras
- Curly (figured) cherry
- Tiger maple
- Birds-eye maple
- Quarter sawn white and red oak
- Sycamore
- And many other lumbers.

Stock changes at all times. Call for availability in species, grade and thicknesses.

1.800.342.0001  
717.284.0001

858 Scotland Road  
Quarryville, PA 17566



[www.groffslumber.com](http://www.groffslumber.com)

## THE 18TH MIDWEST SCROLL SAW & WOODWORKING TRADE SHOW

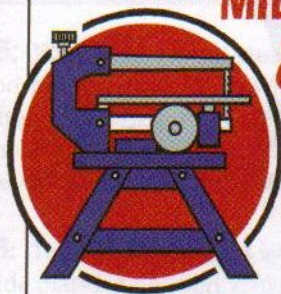

August 19 & 20, 2016  
Friday 9am-5pm and  
Saturday 9am-3:30pm

In the Grand Ballroom on the Dubuque County Fairgrounds  
14569 Old Highway Road, Dubuque, Iowa

### TWO BIG DAYS

filled with classes, seminars, demonstrations, contests, door prizes, and much more! Scrolling, intarsia, woodturning, woodcarving, pyrography...

### THIS SHOW HAS IT ALL!

Tickets: \$5 each day, or both days for \$8 (children under 16 FREE)

For more information call

The Art Factory at 608-348-8332  
or visit [www.midwesttradeshow.com](http://www.midwesttradeshow.com)

## Just FLOCK IT! with DonJer Spray-on Fibers

Line Box and Gourd Interiors in just minutes.

Create soft, fuzzy effects on your wood crafts such as:

- |               |                      |
|---------------|----------------------|
| Santas        | Clouds               |
| Dolls         | Angels               |
| Toy Furniture | Flower Petals        |
| Jewelry       | Model Car Seats      |
| Decoys        | Tree Ornaments       |
| Tool Handles  | Fretwork Backgrounds |

....the possibilities are endless!

Available in over 30 colors.

Call for brochure & color chart 800-336-6537

Flock It! d/b/a DonJer Products Co.  
13142 Murphy Rd., Winnebago IL 61088

[www.donjer.com](http://www.donjer.com)



Fretwork



Scrollin'



Intarsia



Word Art



Marquetry

### Scrollsaw Association of the World

Scrollers come in all ages, sizes, genders, and interests. Some prefer cutting fretwork, others create beautiful artwork in wood intarsia, while still others cut beautiful plaques with messages, and others work on the intricate designs of marquetry.

Consider joining the thousands of Scroll Saw artists by...

CONTACTING SAW: [www.saw-online.com](http://www.saw-online.com)

EMAIL: [info@SAW-online.com](mailto:info@SAW-online.com)

# Puppy Coin Bank



**Cut this cute project and have the little ones help you assemble it**

*By Paul Meisel*

**K**ids love puppies. This one will encourage them to save their coins. Don't be afraid to let the kids help with the final assembly and finishing!

## **Selecting the Wood**

A 6' (1,829mm) length of 1x8 lumber, which typically measures  $\frac{3}{4}$ " by  $7\frac{1}{4}$ " (19mm by 184mm), provides enough material to make this project.

## CUTTING & ASSEMBLING THE PARTS

### Step 1: Transfer the pattern to the blank.

Note the grain direction indicated on the pattern. Cut one body center, two body sides, and two legs. Save the oval cutouts from the body side and leg pieces to use as a plug when drilling the 1 1/4" (32mm)-diameter hole later. Drill the holes marked on the sides and sand away any fuzzies. Glue and clamp a body side to each side of the body center. Then, glue and clamp a leg to each side of the assembly. Note the two 1/4" by 3/8" by 7/8" (6mm by 10mm by 22mm) spacers glued into the coin slot to reduce the width of the slot.

**Step 2: Place the oval center cutouts (cut in Step 1) back inside the assembly.** The cutouts serve as "backer blocks" to help reduce tear out of the hole through the assembly. Turn the assembly upside down and clamp it securely to a drill press table. Set the drill press to the slowest speed. Use a Forstner bit to drill a 1 1/4" (32mm)-diameter hole through the assembly. After drilling, remove and discard the oval cutouts.

**Step 3: Rip the lumber down to 2" (51mm) wide for the ears.** Then, resaw this piece to 1/2" (13mm) thick with the table saw. Attach the patterns, cut the ears, and glue and clamp them in position, referring to the full-size drawing of the body side.

**Step 4: Sand the inside of the oval cavity.** I use a spindle sander. Then, sand all of the other accessible parts of the project smooth.

## FINISHING THE BANK

**Step 5: Wipe on a coat of stain.** I use fruitwood, but any medium brown stain will work. I use Delta water-based craft paint for the black facial features and the red collar. Seal and protect the bank with a coat of Delta clear satin varnish.

**Step 6: Tap the plastic eyes in place.** Place the plastic side plates in position, and drill 1/16" (2mm)-diameter by 1/2" (13mm)-deep screw pilot holes, where shown in the drawing of the leg. Attach the side plates with #4, 1/2" (13mm)-long round-head screws.

**Step 7: Insert the plastic coin bank plug in the bottom.** The plastic plug may first appear as though it won't fit into the hole. The trick is to position the plug and, with your thumb in the center, push very hard. The plug will stretch slightly and seat safely in the hole.



## Materials & Tools

### Materials:

- Pine, 3/4" (19mm) thick: 7 1/4" x 6' (184mm x 1,829mm)
- Sandpaper
- Wood glue
- Stain: fruitwood or medium brown
- Acrylic paints, such as Delta Ceramcoat: red (#02507, 2 oz.)\*, black (#02506, 2 oz.)\*
- Varnish, such as Delta Ceramcoat: clear satin (#07003, 8 oz.)\*
- Coin bank hardware kit (#3015)\* which includes 2 each clear acrylic side plates, 8 each round-head side plate screws, coin bank plug

- Plastic puppy eyes: 2 each 7/16" (11mm) dia. with a 1 3/4" (5.2mm)-dia. shank (#8627)\*

### Tools:

- Table saw
- Blades, such as Olson: #5 reverse-tooth #446-R\*

- Drill press with bits: 1/16" (2mm), 1 3/4" (5.2mm)-dia. twist; 1 1/4" (32mm)-dia. Forstner
- Spindle sander
- Paintbrushes
- Clamps
- Phillips screwdriver: size #1

### SPECIAL SOURCES:

The items above marked with an asterisk (\*) are available from Meisel Hardware Specialties. Call 1-800-441-9870 or visit their website, [www.meiselwoodhobby.com](http://www.meiselwoodhobby.com).

## Cutting diagram

1" x 8" x 6'

**Assembly drawing**

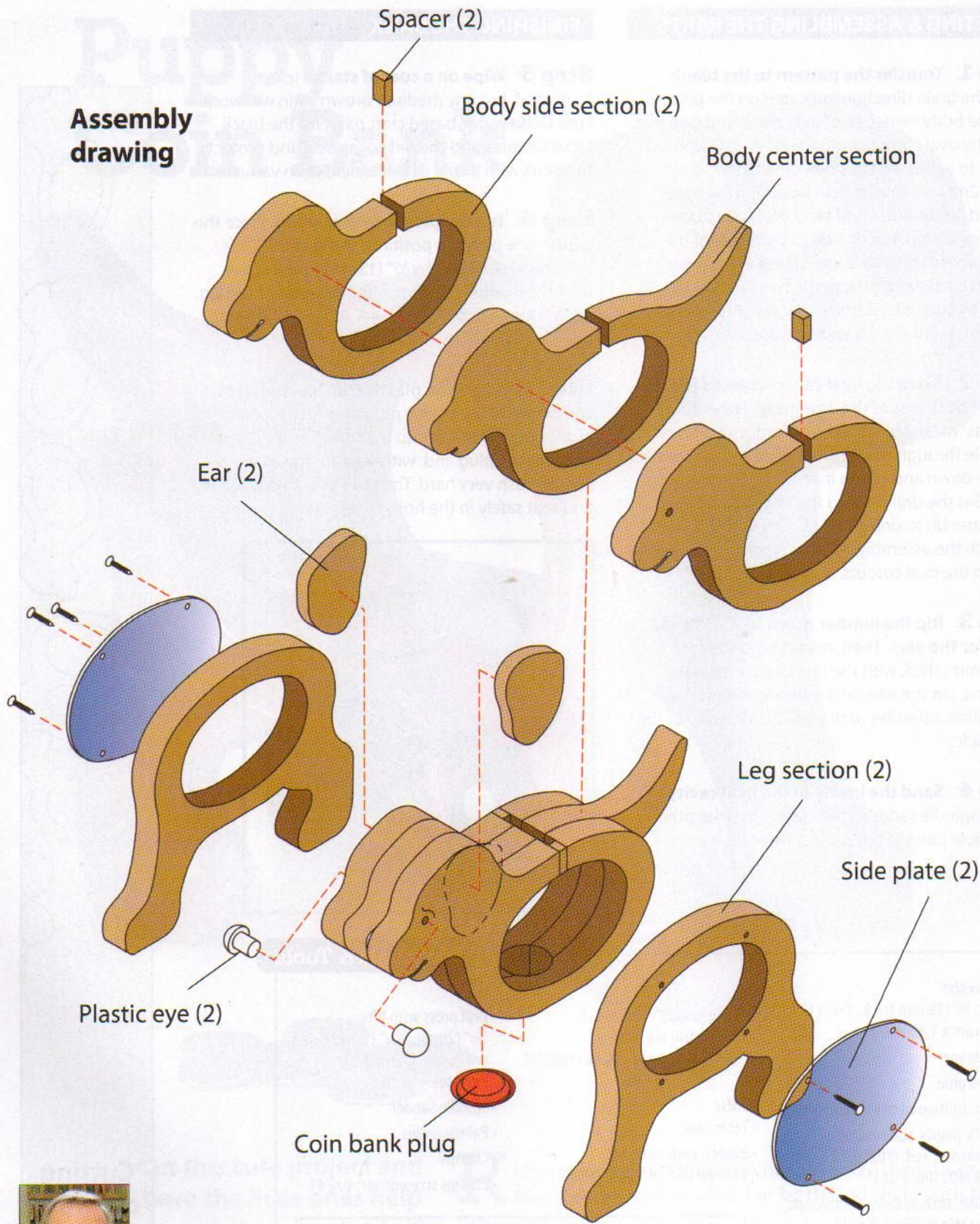

Paul Meisel and his team at Meisel Hardware Specialties have designed over 3,500 projects and plans for the home hobbyist woodworker. Dozens of projects from Paul's collection have appeared in *Scroll Saw Woodworking & Crafts* magazine.

Patterns for the **PUPPY COIN BANK** are in the pattern pullout section.

# 10 Square Foot Project Packs Available...

**WEST PENN**  
HARDWOODS, INC.

Domestics & Exotics

Purpleheart, Zebrawood, Paduak, Bocote, Curly Soft Maple... and many other species, including Bubinga and Canarywood!  
1/8", 1/4", 3/8", 1/2" and 3/4" thickness by 3 - 8" wide and 18 - 36" lengths.

Use Coupon Code: **SSW10** on your next order to receive **10% OFF**. Coupon cannot be combined with any other offers and excludes the following species: Tulipwood, Kingwood, Cocobolo, Amboyna, Waterfall Bubinga and Ebony.

[www.westpennhardwoods.com](http://www.westpennhardwoods.com)

1405 Deborah Herman Road  
Conover, NC 28613

828-322-WOOD (9663)

Like us on Facebook!



# Flying Dutchman



Mike has retired - New Location

**Same Great Service!**

## Ultra Reverse Scroll Saw Blade

Available in sizes **\$3.50** / dozen  
#1, 3, 5, 7 & 9 **\$19.50** / 1/2 gross  
\$3.00 shipping & handling. **\$33.60** / gross

## MIKE'S WORKSHOP

P.O. Box 33917 • Portland, OR 97292  
Ph: 503-760-1614 • Fax: 503-761-2674

[www.mikesworkshop.com](http://www.mikesworkshop.com)

Once you try it, you'll never go back!

# Want More SSW?

Sign up for our e-mail newsletter

## SHORT CUTS

It's like a FREE mini-issue in your e-mail **four times a year**. Visit [scrollsawer.com/enews](http://scrollsawer.com/enews) to sign up today!

Check out our archives at [scrollsawer.com/category/enews-short-cuts/](http://scrollsawer.com/category/enews-short-cuts/)



# PROXXON

DSH/E 37090



- electronic stroke control
- extremely low vibration
- very precise cutting

**PROXXON** (Germany) manufactures the largest variety of miniature power tools in the world.

For more information: PROX-Tech, Inc., P.O. Box 1909, Hickory, NC, 28603-1909 Toll free 1-877-PROXXON, [sales@prox-tech.com](mailto:sales@prox-tech.com)

[www.proxxon.com/us](http://www.proxxon.com/us)

To avoid repetitive instructions, this page is included in each issue to assist novice scrollers with basic scrolling techniques.

## Squaring Your Table

Most scroll saws have an adjustable table that allows you to make cuts at different angles. There are times when you want the saw set at an angle, but most cutting is done with the blade perpendicular to the table. If the table is even slightly off-square, the cuts will be angled. This interferes with puzzle pieces, intarsia, segmentation, and many other types of scrolling projects.

The most common method for squaring a table uses a small metal square, or right angle tool. Set the square flat on the saw table against a blade that has been inserted and tensioned. Adjust the table to form a 90° angle to the blade.

The cutting-through method is also popular. Saw through a piece of scrap wood at least 3/4" (19mm) thick and check the angle of the cut using a square. Adjust the table until you get a perfectly square cut.

You can also use the kerf-test method. Take a 1 3/4" (44mm)-thick piece of scrap wood and cut about 1/16" (2mm) into it. Stop the saw, back the blade out, and spin the wood around to the back of the blade. If the blade slips easily into the kerf, the table is square. If it doesn't slide into the kerf, adjust the table and perform the test again until the blade slips in easily.

## Attaching Patterns

Temporary-bond spray adhesive is the most common method used to attach patterns to stock. Photocopy the pattern. Spray the adhesive on the back of the copy of the pattern, wait a few seconds, and then press the pattern down onto the blank. Rubber cement or glue sticks work similarly.

You can also use graphite or carbon transfer paper. Place the pattern on the blank and slip a sheet of transfer paper

in between the pattern and the blank. Use a few pieces of painter's tape to hold the pattern and transfer paper in place. Trace around the pattern with a red pen (so you know where you have traced). Choose a light-colored transfer paper for darker woods. Carbon paper costs less than graphite paper, but must be sanded off before finishing.

## Stack Cutting

Stack cutting lets you cut several pieces of a project—or even several projects—at one time. Essentially, you attach several blanks together and cut them as one unit.

One way to attach blanks is with tape. Line all the layers up and wrap a layer of tape around the outside edge. You can also wrap the whole stack in tape for extra stability. Use masking tape, painter's tape, or clear packaging tape.

Hot-melt glue is another option. Glue the blanks together with a dot of hot-melt glue on each side.

You can also join pieces by driving brads or small nails into as many waste areas as you can. Cut off any overhanging nails as close to the surface as you can, and then sand them flush to avoid scratching or catching on the table.

## Blade Tension

Before inserting a blade, completely remove the tension. Clamp both ends of the blade into the blade holders and adjust the tension. Push on the blade with your finger. It should flex no more than 1/8" (3mm) forward, backward, or side to side.

A blade that does not have enough tension will wander. It will also flex from side to side, making for irregular or angled cuts. If you press too hard on a loose blade, it will usually snap. A blade that has too much tension is more susceptible to breaking and tends to pull out of the blade holders. In general, it is better to make the blade too tight rather than too loose.

## Blade-Entry Holes

Some patterns have blade-entry holes marked. If the pattern doesn't, place the holes near a line to be cut to prolong the blade life, but don't place the hole on a curving line or inside corner (if possible). Drill the hole perpendicular to the blank. Use a drill press if you have one; otherwise, use a hand drill and make the holes as vertical as possible. Drill through the blank into scrap wood to prevent tear-out on the back side of the blank.

If you have the space, use a larger bit—it will make it easier to thread the blades through. For thin veining cuts, use the smallest bit the blade will fit through.

## Removing Patterns

Dampen a glued paper pattern with mineral spirits to aid in removal. Commercial adhesive removers work as well. A quick wipe of mineral spirits will remove most adhesives left behind on the wood.

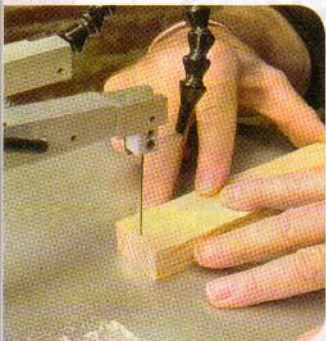
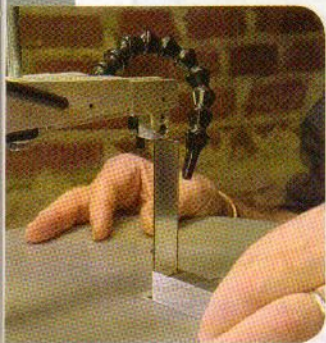

IN OUR  
NEXT  
ISSUE



Decorate your home with a stunning lath segmentation.

Learn how to make lures that really catch fish.



Build an animated night-light for a child's bedroom.

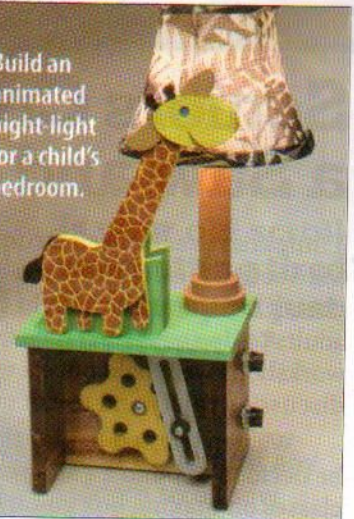

## ADVERTISING DIRECTORY

Advanced Machinery – Inside Back Cover  
800-SCROLLER  
[www.advmachinery.com](http://www.advmachinery.com)

Bushton Manufacturing – page 11  
620-562-3557  
[www.hawkwoodworkingtools.com](http://www.hawkwoodworkingtools.com)

Carving Technologies – page 11  
913-708-8083  
[www.carvingtechnologies.com](http://www.carvingtechnologies.com)

D&D Woodcrafts - page 13  
610-381-2286  
[www.dndhardwoodsonline.com](http://www.dndhardwoodsonline.com)

Flock It – page 65  
800-336-6537  
[www.donjer.com](http://www.donjer.com)

Graphic Transfer – page 15  
928-453-2652  
[www.graphictransfer.net](http://www.graphictransfer.net)

Grobet USA – Back Cover  
800-847-4188  
[www.grobetusa.com](http://www.grobetusa.com)

Groff & Groff Lumber – page 65  
800-342-0001  
[www.groffslumber.com](http://www.groffslumber.com)

JET Tools – page 7  
[www.jettools.com/scrollsaw](http://www.jettools.com/scrollsaw)

King Arthur's Tools – page 9  
800-942-1300  
[www.katools.com](http://www.katools.com)

Midwest Scroll Saw & Woodworking  
Trade Show – page 65  
608-348-8332  
[www.midwesttradeshow.com](http://www.midwesttradeshow.com)

Mike's Workshop – page 69  
503-760-1614  
[www.mikesworkshop.com](http://www.mikesworkshop.com)

Ocooch Hardwoods – page 71  
888-322-2432  
[www.occoochhardwoods.com](http://www.occoochhardwoods.com)

Prox-Tech, Inc. – page 69  
877-PROXXON  
[www.proxxon.com/us](http://www.proxxon.com/us)

PS Wood Machines – page 15  
800-939-4414  
[www.pswood.com](http://www.pswood.com)

Scrollsaw Association of the World – page 65  
[www.saw-online.com](http://www.saw-online.com)

Seyco, Inc. – page 1  
800-462-3353  
[www.seyco.com](http://www.seyco.com)

Sloan's Woodshop – page 5  
888-615-9663  
[www.sloanswoodshop.com](http://www.sloanswoodshop.com)

SuperMax Tools – page 13  
888-454-3401  
[www.supermaxtools.com](http://www.supermaxtools.com)

West Penn Hardwoods – page 69  
828-322-WOOD (9663)  
[www.westpennhardwoods.com](http://www.westpennhardwoods.com)

Wooden Teddy Bear – Inside Front Cover  
888-762-9149  
[www.woodenteddybear.com](http://www.woodenteddybear.com)



### Scroll Saw Ready Hardwoods

1/8" to 3/4" thick and  
4" to 12" wide

- Lower Prices
- Fast Service
- Satisfaction Guaranteed

Carving Stock  
Turning Blanks  
Intarsia Lumber  
Plywood

Order online or call toll free  
[www.OcoochHardwoods.com](http://www.OcoochHardwoods.com)

**Free Catalog**  
1-888-322-2432

# Seniors Create Music with a Saw and a Song

Things have really been strumming along at the Senior Citizen Center in Marinette, Wis., since Warren McKenney started teaching guitar-making classes to seniors. "I thought it would be a great opportunity for seasoned adults to do something nice for themselves," said Warren. The two-hour workshops were held once a week for nine weeks. "We started the classes by discussing safety and use of materials and tools. Then we got to work!"

Warren learned to play the guitar as a child. Ten years ago, on a whim, he decided to build a guitar out of old wooden pallets. He has since taught classes on making box guitars, ukuleles, electric guitars, and acoustic guitars from recycled, reclaimed, and repurposed materials collected from what he calls "high-end dumpsters."

"Never throw anything away if you might be able to reuse it. That's my concept. I guess I'm a tree hugger at heart," he said with a chuckle.

During the class, seniors learned how to operate a scroll saw, a detail sander, and a rotary tool, and worked with many different hand tools. "They used the scroll saw to cut out the instruments and create the sound holes and headstocks. The sound chambers, equipment pockets, and pick-up pockets were also done with a scroll saw," Warren explained. "Considering none of the students had ever used a scroll saw, or even worked with wood before, I think the class went extremely well. Everyone did a great job, and they've all got the guitars to prove it!"

Contact Warren at [macsguitars@yahoo.com](mailto:macsguitars@yahoo.com).

Learn more about his work at [youtu.be/5mW7fsGtxZM](http://youtu.be/5mW7fsGtxZM).

Guitar maker and teacher Warren McKenney.

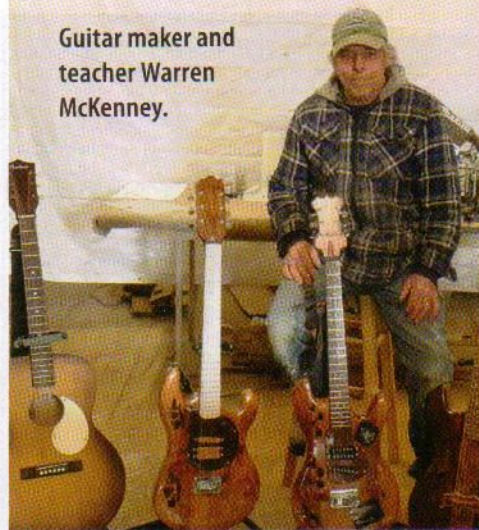

Guitar-making students at the Senior Center in Marinette, Wis. (Left to right): Gene Voelker, Mary Hasse, Nick Cherubini, Greg Sevener, and (not pictured) Dianne Woods.

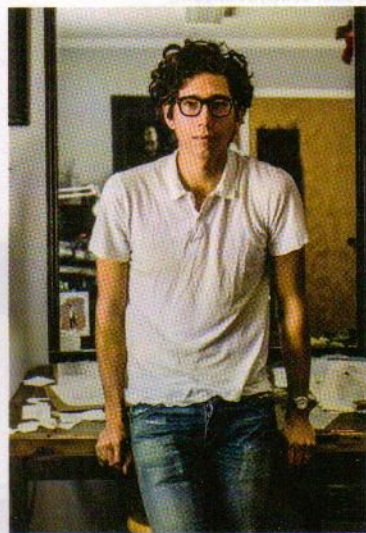

Wesley Knight in his workshop.

## Exclusively Scrolled Eyewear

Wesley Knight, a 26-year-old entrepreneur from Franklin, Tenn., proves that there is no end to what one can accomplish with a scroll saw by scrolling water buffalo horns into high-end eyewear. "I was attracted to real horn frames from the '40s and '50s that I'd seen in a magazine and thought, 'I can do that,'" Wesley recalled. Already an accomplished craftsman in multiple disciplines, he knew the scroll saw would be perfect for cutting the hard horn frames.

During a trip to London, Wesley learned of an old-world luxury process called bespoke, where a maker creates items specifically designed for a commissioner. In 2013, Wesley combined his ethically sourced horn frames with the bespoke concept to form Wesley Knight Bespoke, a neo-heritage eyewear company that translates an individual's personality and facial features into unique handmade horn eyewear. "I taught myself how to fit and measure the human face, create patterns, and construct the horn eyewear using my Excalibur scroll saw," he said. Each frame is cut from the client's choice of water buffalo horn, which is 35% lighter than acetate, hypoallergenic, and nonconductive. "Buffalo horn is very hard, like resin or plastic, and unforgiving compared to most soft woods. It takes a lot of cutting and requires very size-specific blades," Wesley explained. "I have a real passion for this work and plan to continue growing the company and exploring the mysteries of this forgotten medium."

View more of Wesley's work at [www.wesley-knight.com](http://www.wesley-knight.com).

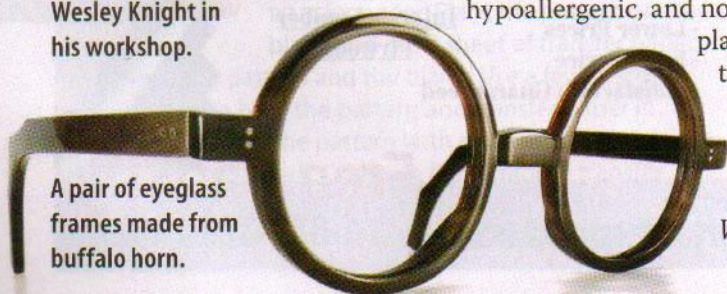

A pair of eyeglass frames made from buffalo horn.

# HEGNER

## The Ultimate Upgrade

HEGNER Multimax  
18-V with HLX7 Deluxe  
Accessory Package.

**Is your old scroll saw getting tired? Or have you just outgrown it?**

**FACT:** Almost any modern scroll saw outperforms older spring-tension saw designs.

**FACT:** Only hand-assembled HEGNER High-Performance Precision Saws from Germany consistently outperform other modern scroll saws.

**FACT:** A HEGNER is The Ultimate Upgrade for your scrolling shop.

Why settle for less? You can own the saw recognized as the American and world-wide standard—the acknowledged leader in its class—for almost 40 years. And your true cost is only pennies a day!

Take your scroll sawing to the next level! Improve your shop today with a HEGNER High-Performance Precision Scroll Saw.

**It's The Ultimate Upgrade.**

Learn more: Call **1-800-SCROLLER** or visit **[www.advmachinery.com](http://www.advmachinery.com)**

Super-Skip

Skip Tooth

Modified Geometry (MGT)

Double Reverse Skip Tooth

Spiral

Coping Skip

Coping Regular

## Super-Skip

If you are looking for a fast, aggressive, high performance blade that leaves a smooth fine finish - look no more - the Super-Skip blade was created especially for you.

Designed for hard and medium hardwoods, it also works well on Acrylic (at reduced speed).

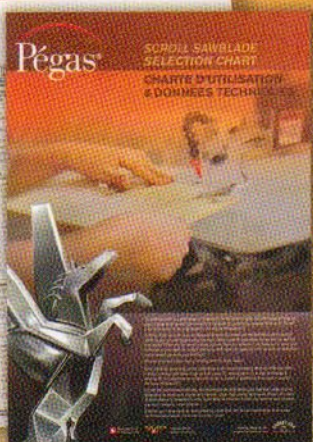

Use our **blades selection chart** to choose the right blade for your project:



For a brochure:  
[pegas@grobetusa.com](mailto:pegas@grobetusa.com)

All Pégas® Sawblades are manufactured in our Swiss factory from the best carbon steel available. Tradition, Precision and Expertise, since 1966, are fundamental in the production of these very high-quality, world-class sawblades.

- Leaves a smooth finish
- Consistent quality
- Alternatively set teeth
- Long lasting

 **Manufactured in Switzerland**



[www.grobetusa.com](http://www.grobetusa.com)  
[pegas@grobetusa.com](mailto:pegas@grobetusa.com)  
800-635-2993



[www.scies.ch](http://www.scies.ch)  
[pegas@scies.ch](mailto:pegas@scies.ch)



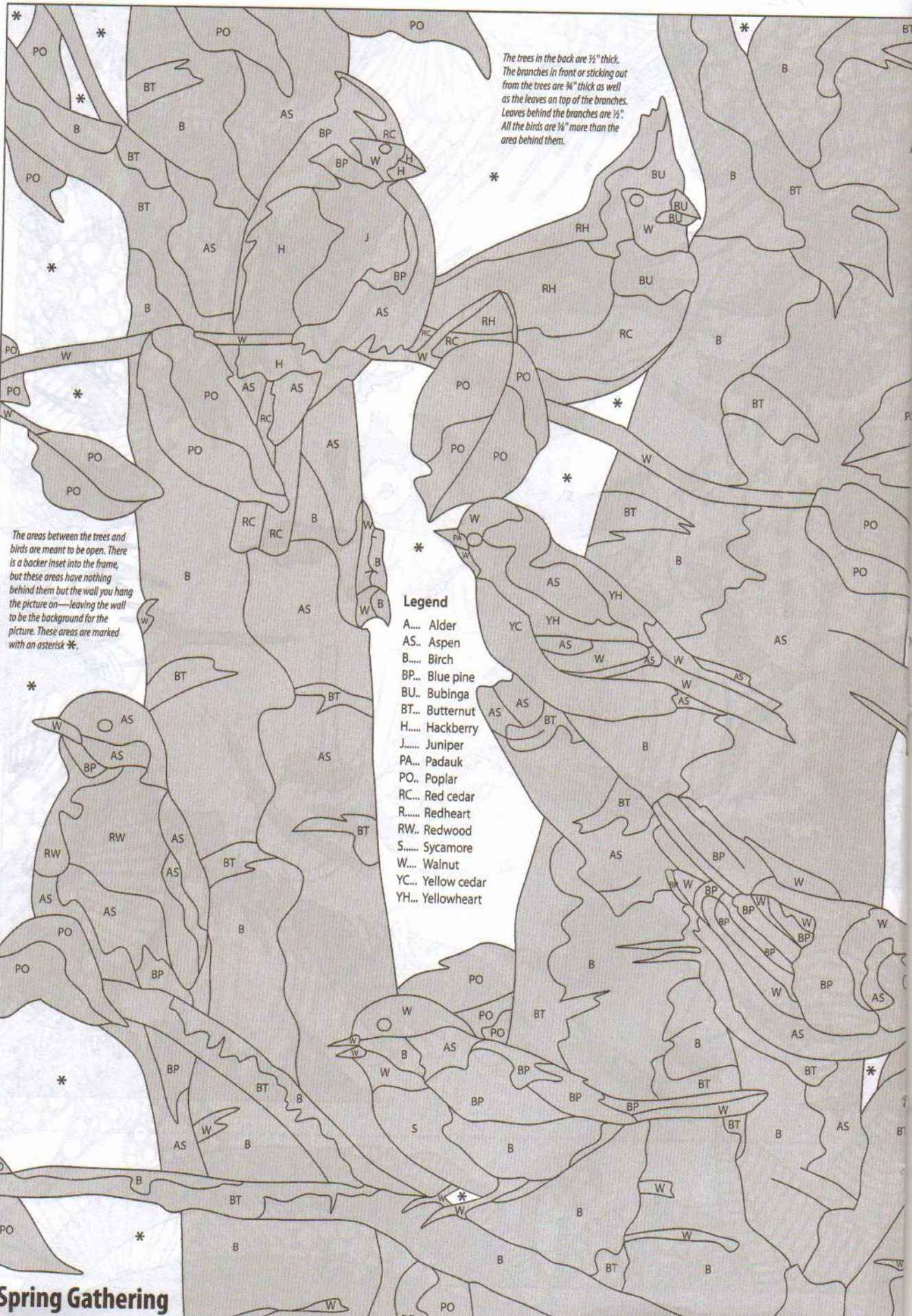

The trees in the back are 1/2" thick.  
 The branches in front or sticking out  
 from the trees are 3/4" thick as well  
 as the leaves on top of the branches.  
 Leaves behind the branches are 1/2".  
 All the birds are 1/4" more than the  
 area behind them.

The areas between the trees and  
 birds are meant to be open. There  
 is a backer inset into the frame,  
 but these areas have nothing  
 behind them but the wall you hang  
 the picture on—leaving the wall  
 to be the background for the  
 picture. These areas are marked  
 with an asterisk \*.

**Legend**

- A.... Alder
- AS.. Aspen
- B.... Birch
- BP... Blue pine
- BU.. Bubinga
- BT... Butternut
- H.... Hackberry
- J..... Juniper
- PA... Padauk
- PO.. Poplar
- RC... Red cedar
- R.... Redheart
- RW.. Redwood
- S..... Sycamore
- W.... Walnut
- YC... Yellow cedar
- YH... Yellowheart

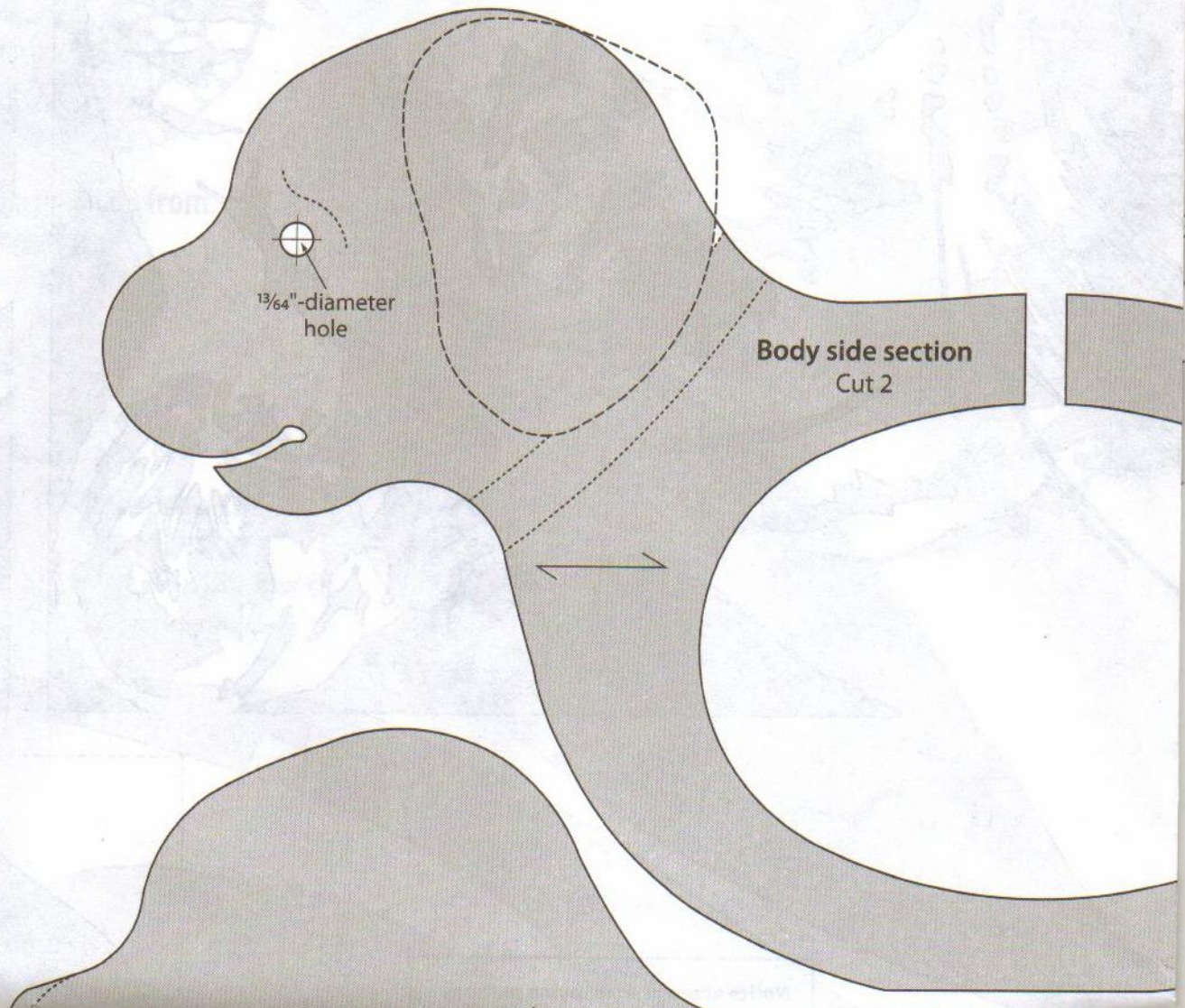
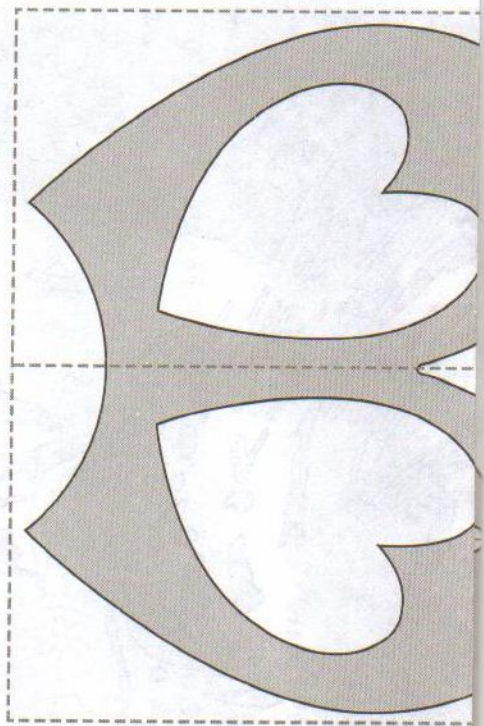
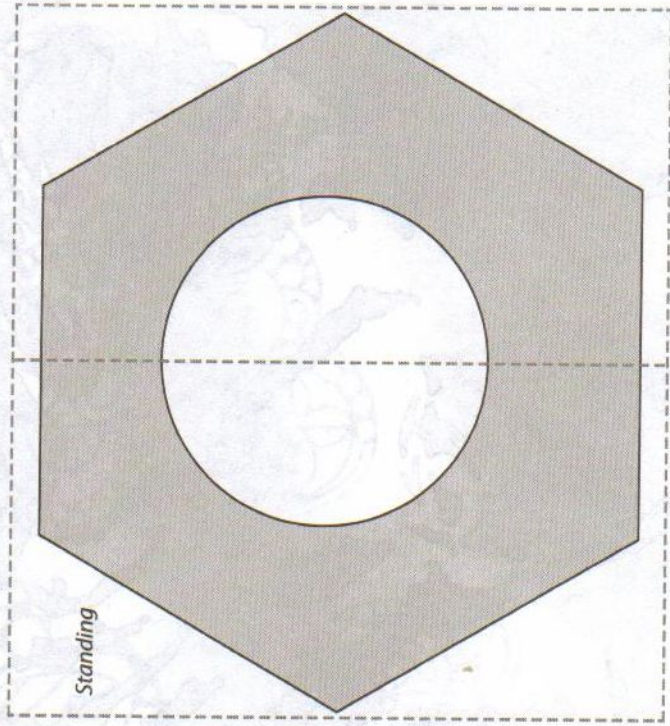

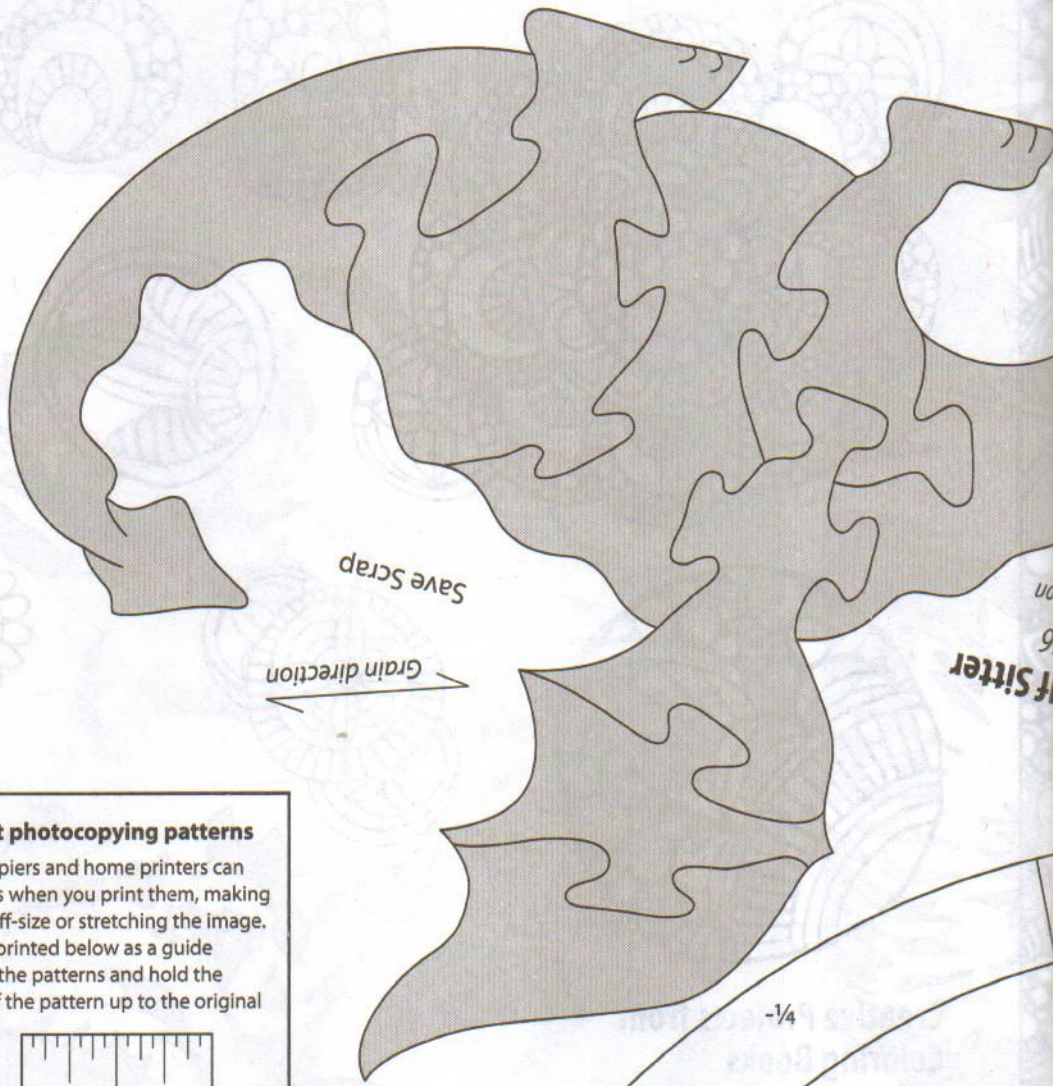
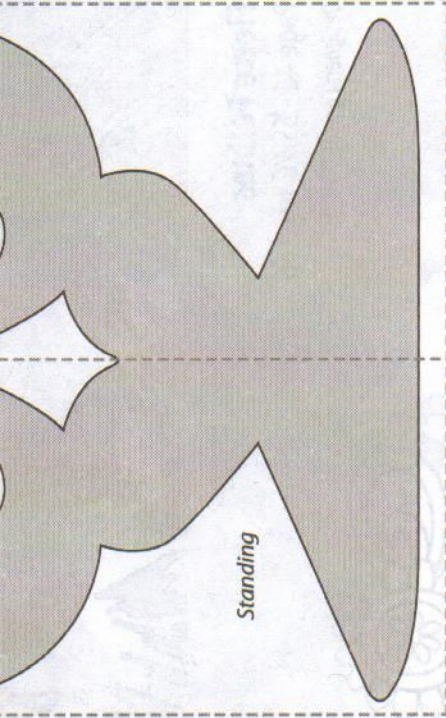

**Notice about photocopying patterns**

Some photocopiers and home printers can distort patterns when you print them, making them slightly off-size or stretching the image. Use the 1" bar printed below as a guide when copying the patterns and hold the photocopies of the pattern up to the original to check for any distortion.



One inch

**Legend**

Start with 3/4" wood

- ← Grain direction
- B..... Ebony / very darkest
- D..... Dark shade of wood
- M..... Medium shade of wood
- MD... Medium dark shade of wood
- M..... Light shade of wood
- ML.... Medium light shade of wood
- W..... Any white wood
- 1/4..... Sand or plane down 1/4"
- +1/4..... Use 1/4" thicker wood
- ..... Riser

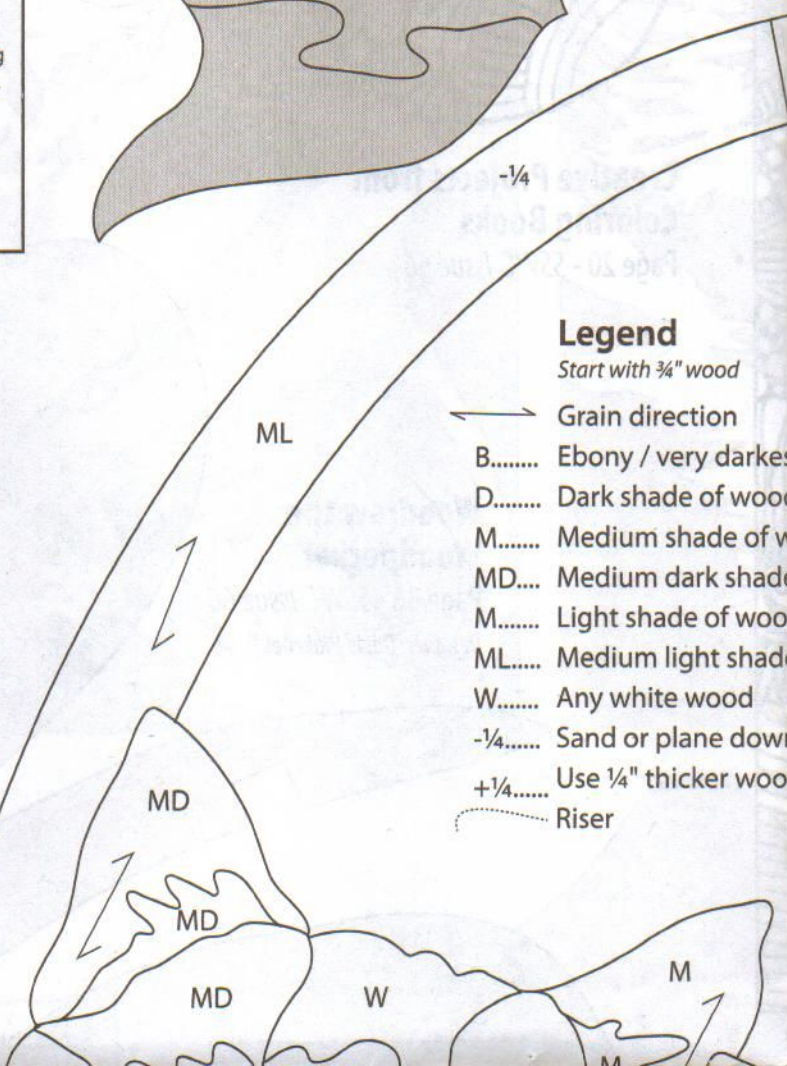
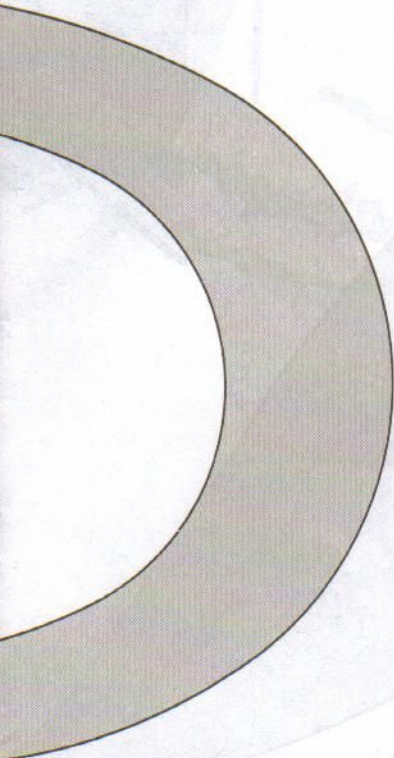

4 W



# SCROLLSAW woodworking & CRAFTS

Spring 2017 - Issue 66

1970 Broad Street  
East Petersburg, PA 17520

All patterns to be copied at 100% unless otherwise indicated.

All patterns on this pullout section: © 2017 Scroll Saw Woodworking & Crafts

Creative Projects from Coloring Books .....	20	Nosy Dragon Shelf Sitter.....	41
Spring Gathering .....	26	Fierce Felines.....	46
Fretwork Heart .....	31	Desktop Rockets.....	52
Air Plant Holders.....	32	Kitty Basket .....	54
Cat Puzzles .....	34	Puppy Coin Bank .....	66
Woodrow the Woodpecker.....	36		

Note to professional copying services. You may make up to ten copies of these patterns for the personal use of the buyer of this magazine.

Nosy Dragon Shelf Sitter  
Page 41 - SSWC Issue  
Designer: Judy and Dave Peters

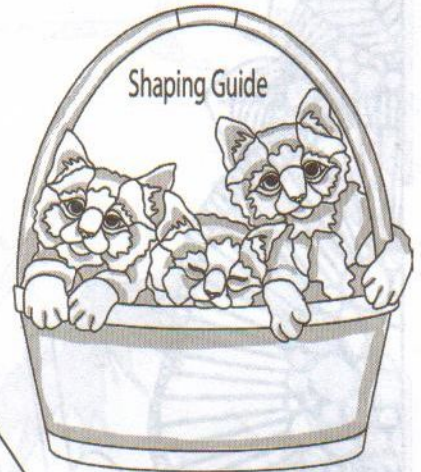
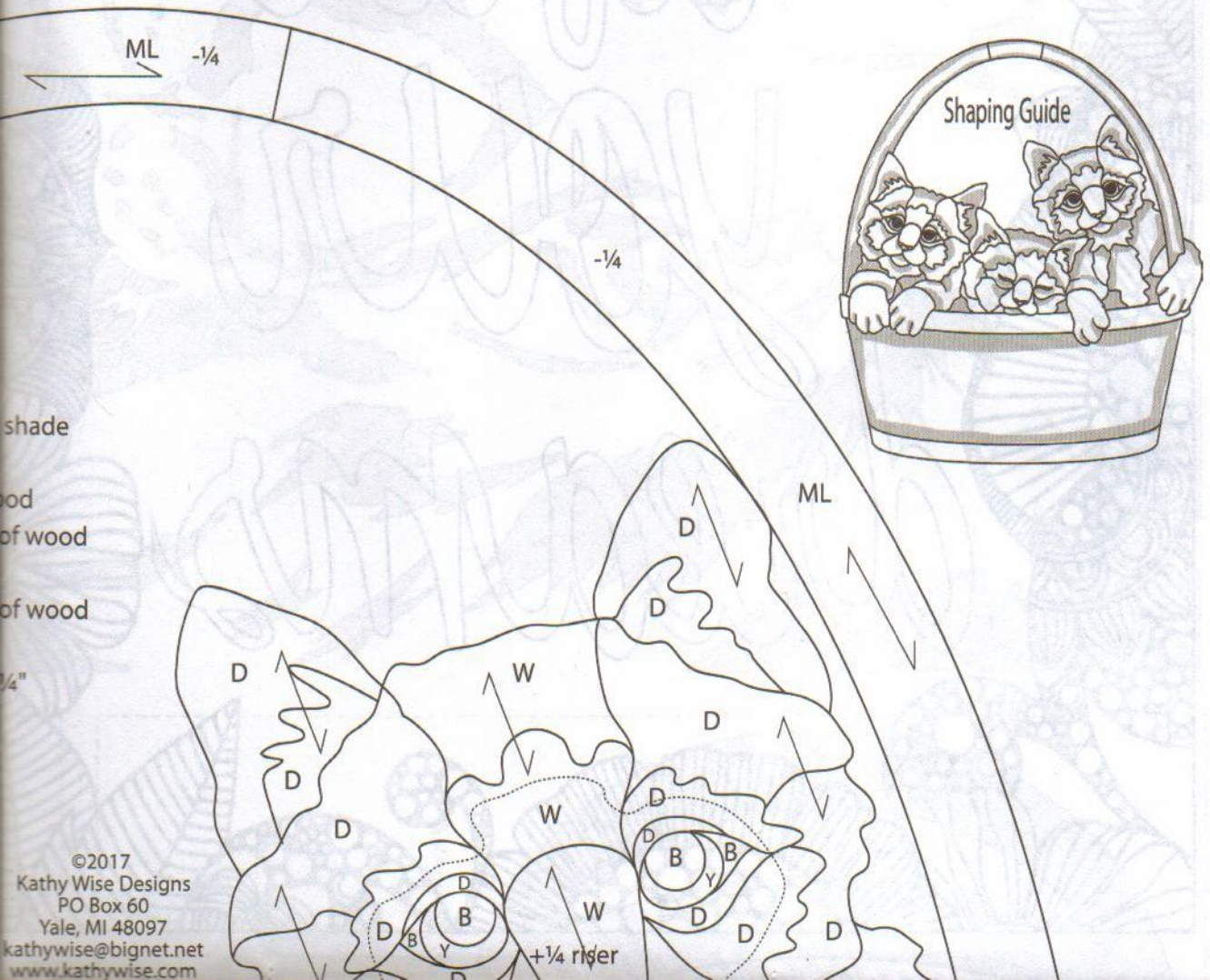

Shaping Guide

shade  
of wood  
of wood  
1/4"

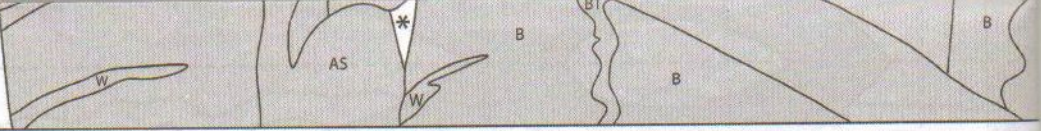

5A

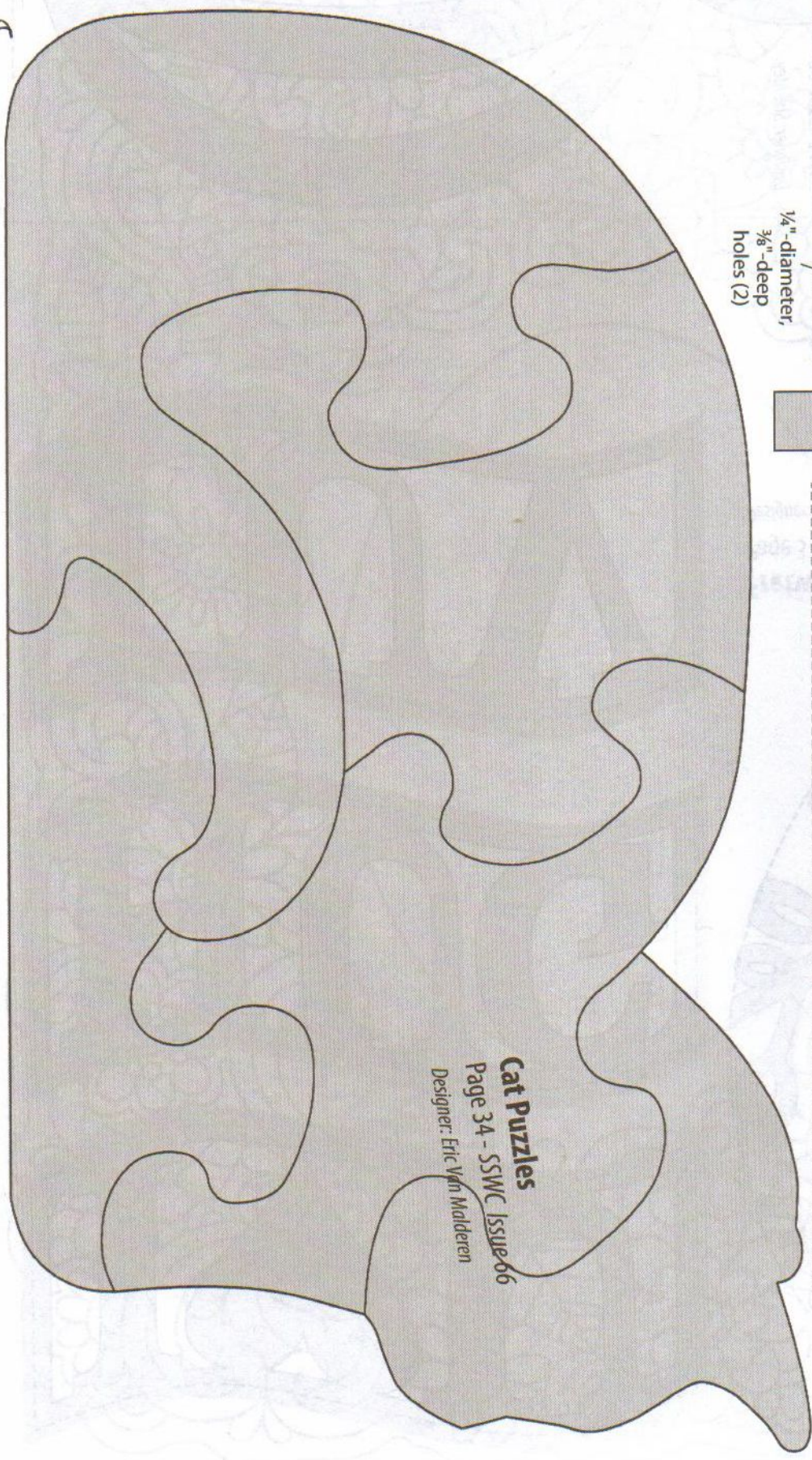

**Cat Puzzles**  
Page 34 - SSWC Issue 66  
Designer: Eric Van Milderren

1/4" diameter,  
3/8" deep  
holes (2)

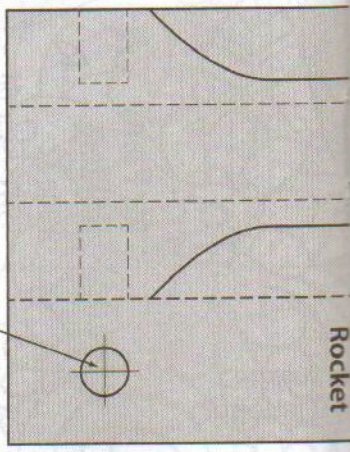

Use a 2" (50mm) forstner bit to drill at the center in the compartment (grey dots indicate)

Hanging

**Air Plant Holders**  
Page 32 - SSWC Issue 66  
Designer: Sue Mey

Body center section  
Cut 1

6A

### Desktop Rockets

Page 52 - SSWC Issue 66

Designer: Bob Gilsdorf

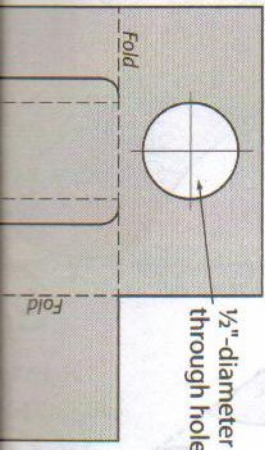

1/8"-diameter hole

1 1/4"-diameter hole  
(after assembly)



(m) diameter  
(spade bit  
opening  
holder  
lines  
opening)

1/16"-diameter holes (4)

Ear  
Cut 2

Leg section  
Cut 2

**Puppy Coin Bank**  
Page 66 - SSWC Issue 66  
Designer: Paul Meisel

7A

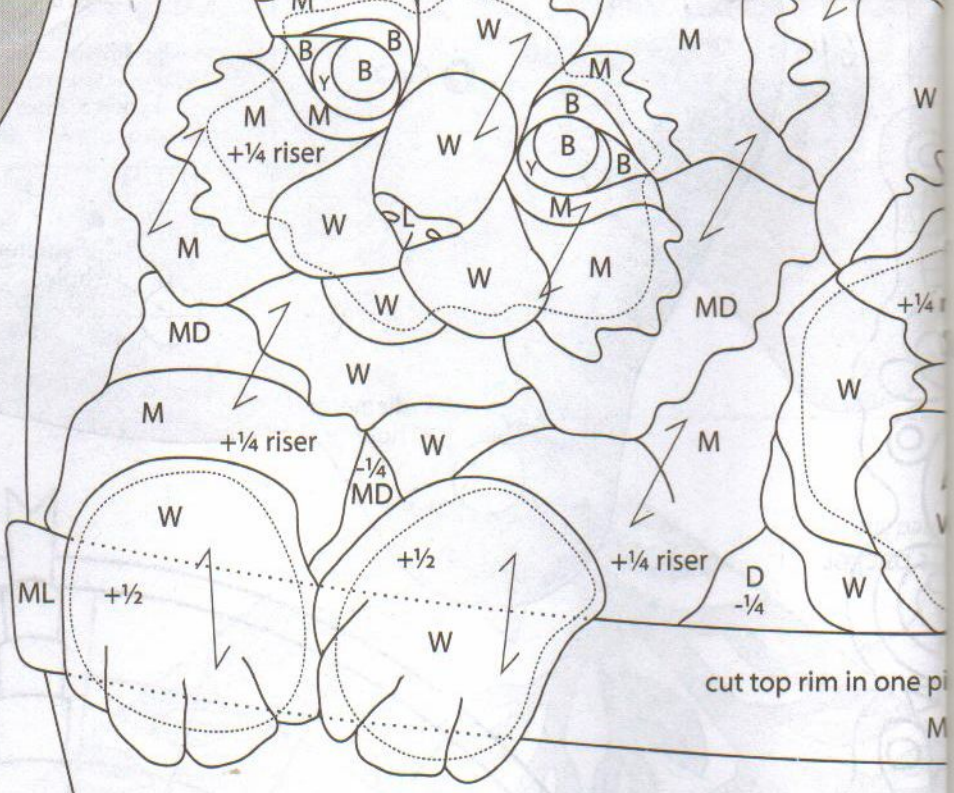

cut top rim in one pi

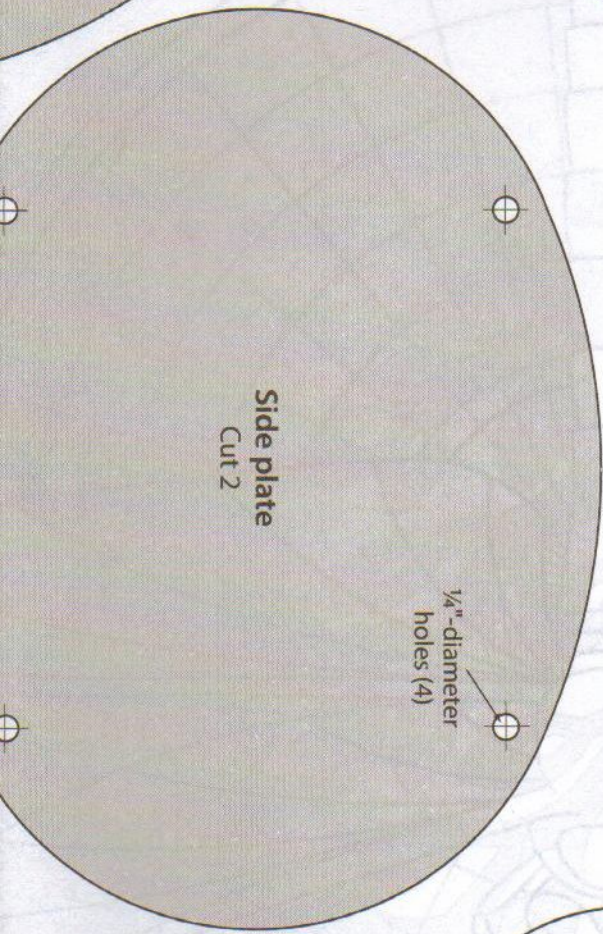

### Kitty Basket

Page 54 - SSWC Issue 66

Designer: Kathy Wise

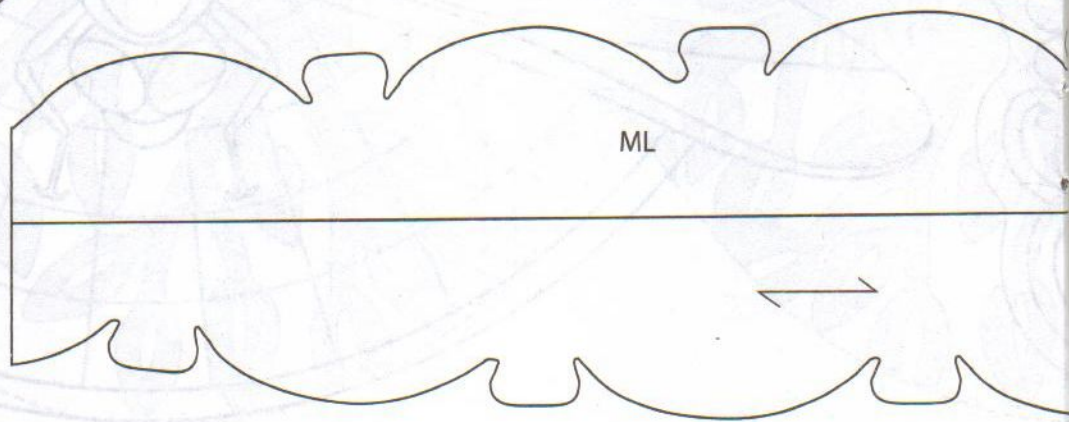



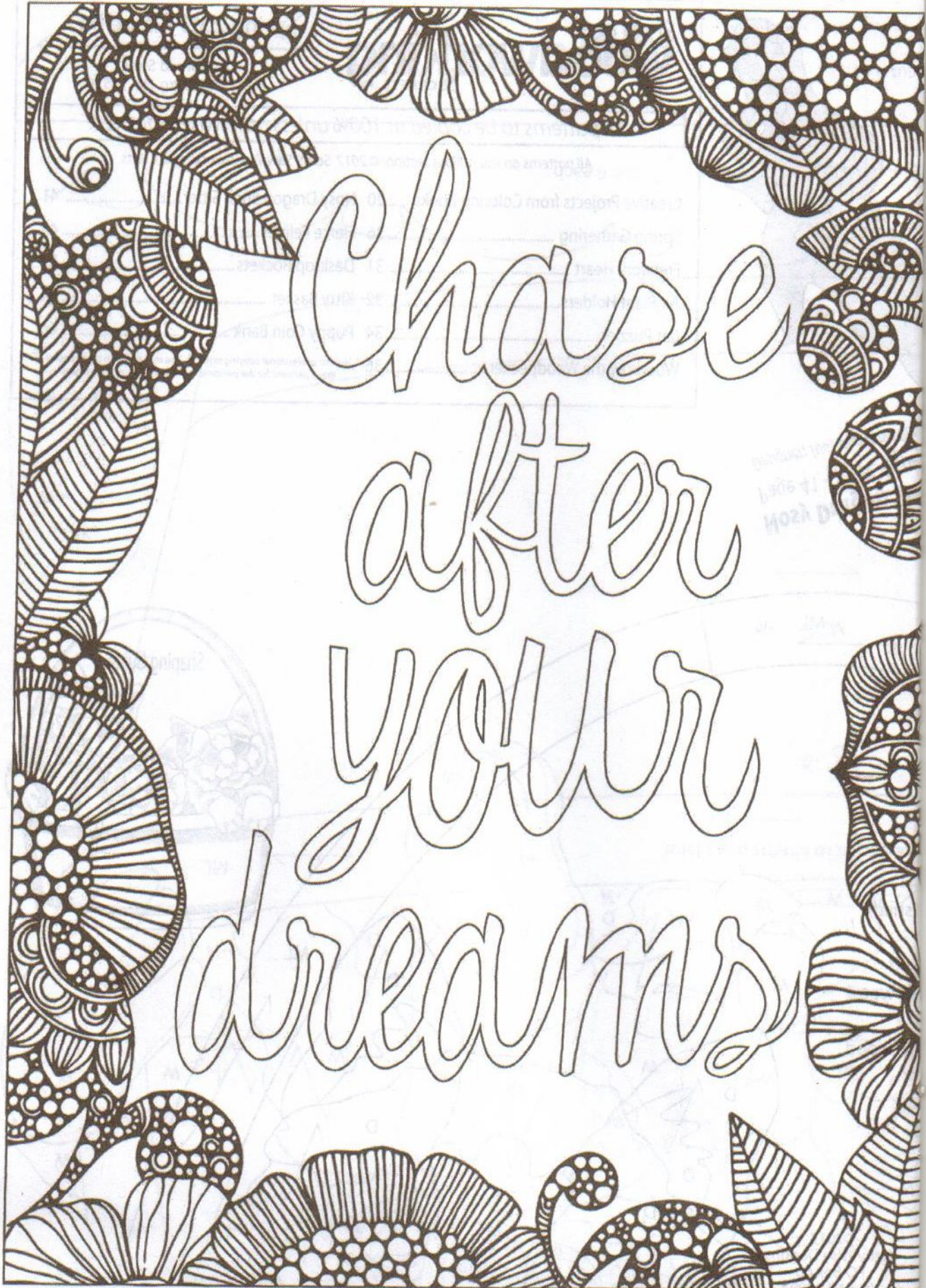

Chase  
after  
your  
dreams

2 B

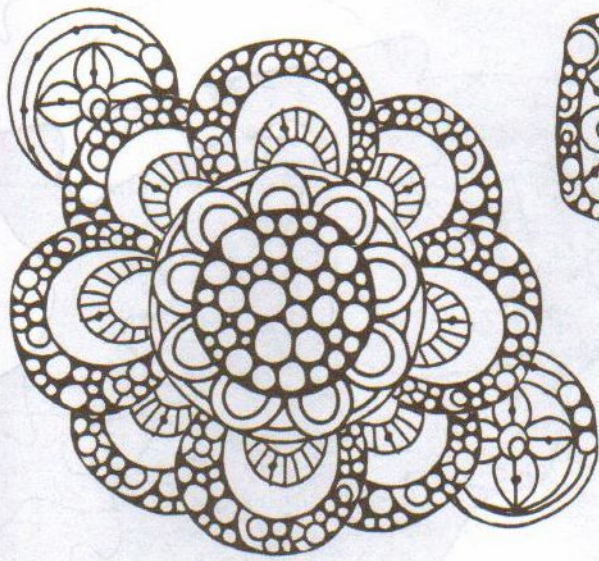

**Creative Projects from  
Coloring Books**

Page 20 - *SSWC Issue 66*

**Woodrow the  
Woodpecker**

Page 36 - *SSWC Issue 66*

Designer: *David Wakefield*

**H** Cut 2

**G** Cut 2

**Fierce Felines**  
Page 46 - *SSWC Issue 66*  
Designer: *Charles Dearing*





Notice about photocopying patterns

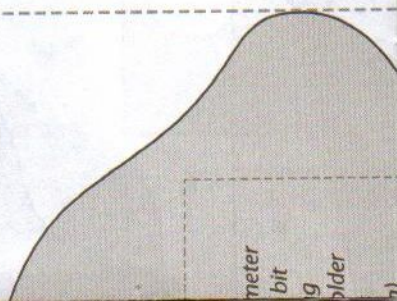

meter  
bit  
g  
p/der



Hangings

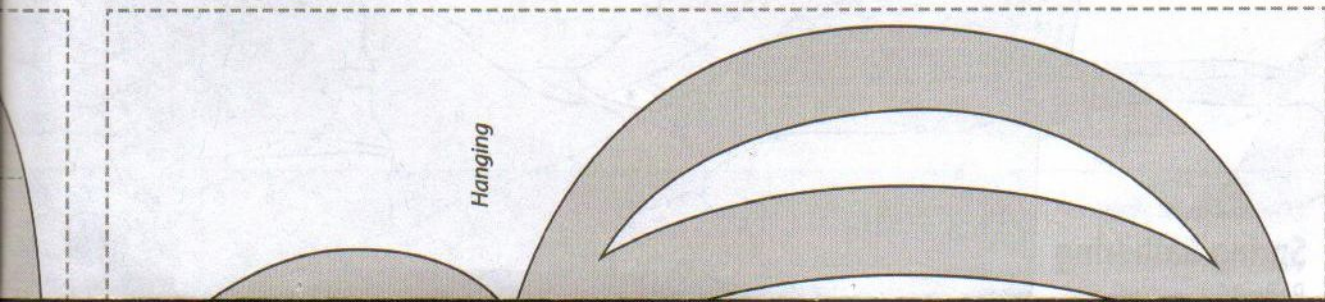

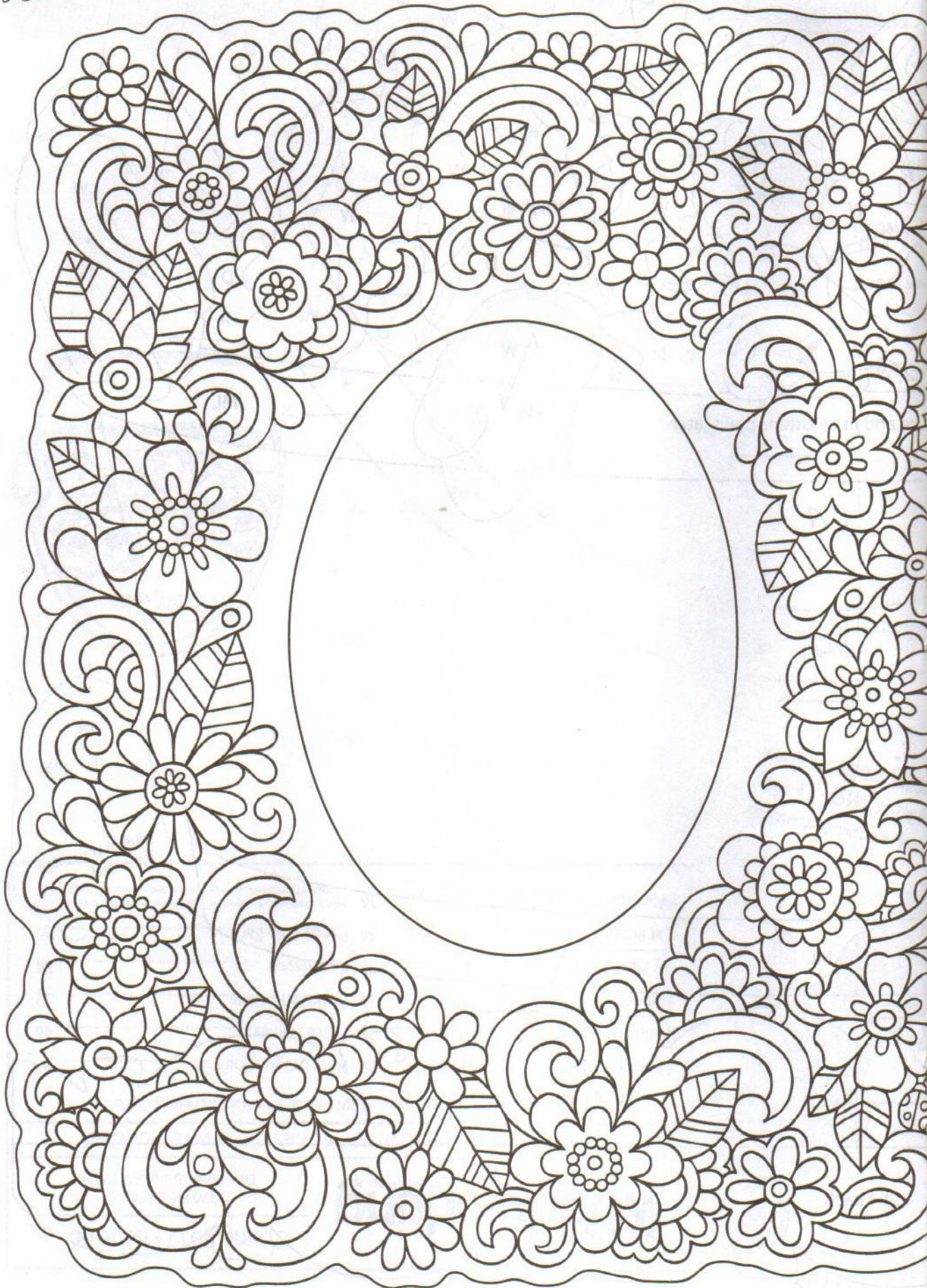

F Cut 2

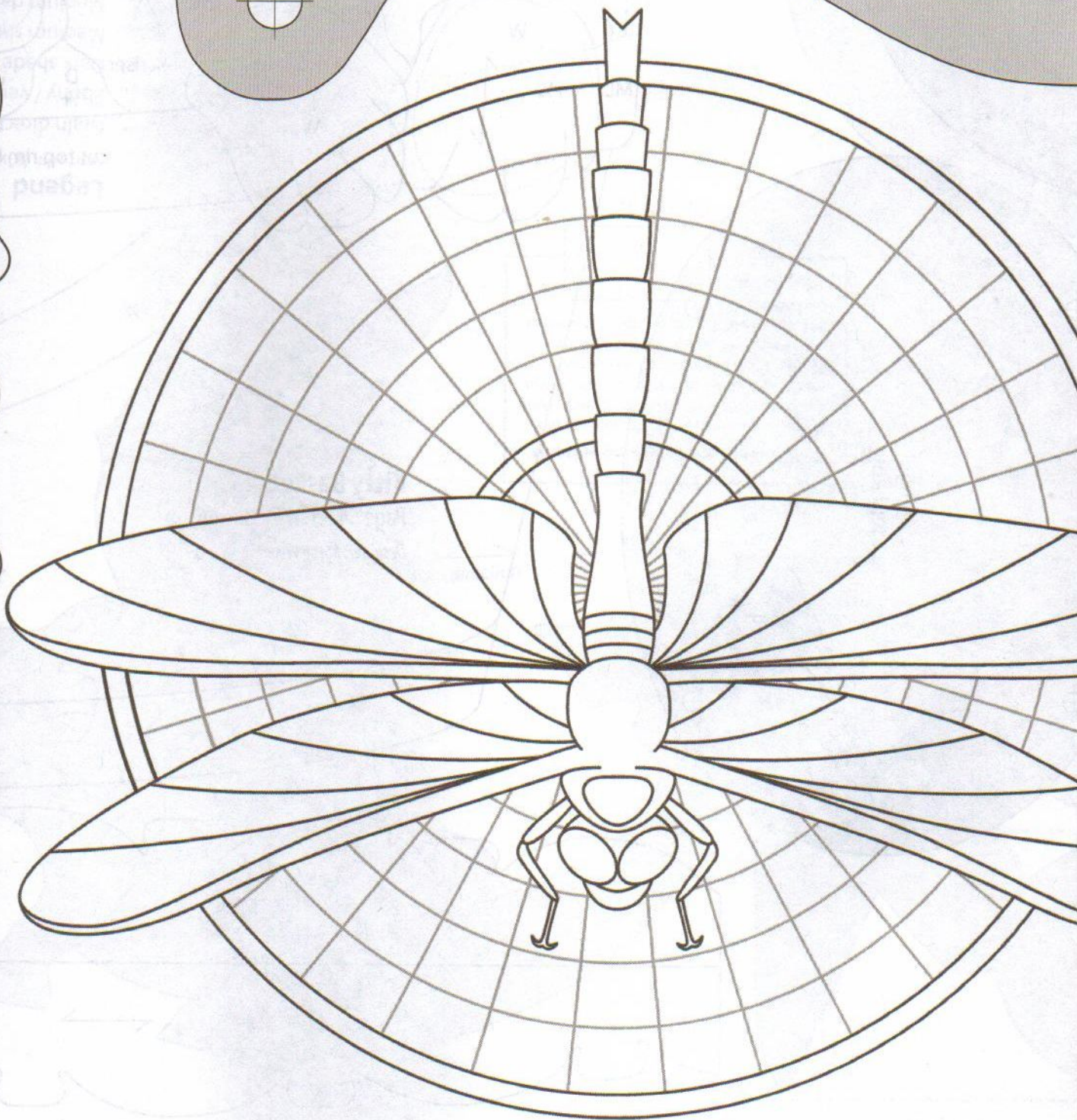
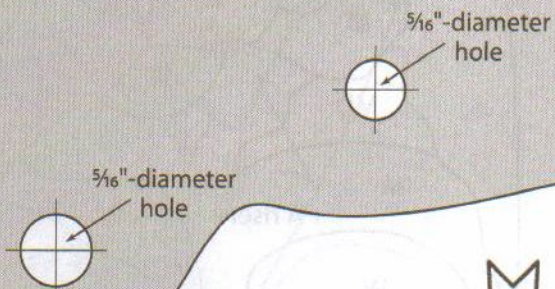

Some photocopiers and home printers can distort patterns when you print them, making them slightly off-size or stretching the image. Use the 1" bar printed below as a guide when copying the patterns and hold the photocopies of the pattern up to the original to check for any distortion.



One inch

Use a 2" (50mm) diameter forstner bit/spade to drill an opening in the completed hanging (grey dash line) indicate mounting

Hanging

Use a 2" (50mm) diameter forstner bit/spade to drill an opening in the completed hanging (grey dash line) indicate mounting



**Air Plant Holders**

Page 32

SSWC Issue 66

Designer: Sue Mey

8 B

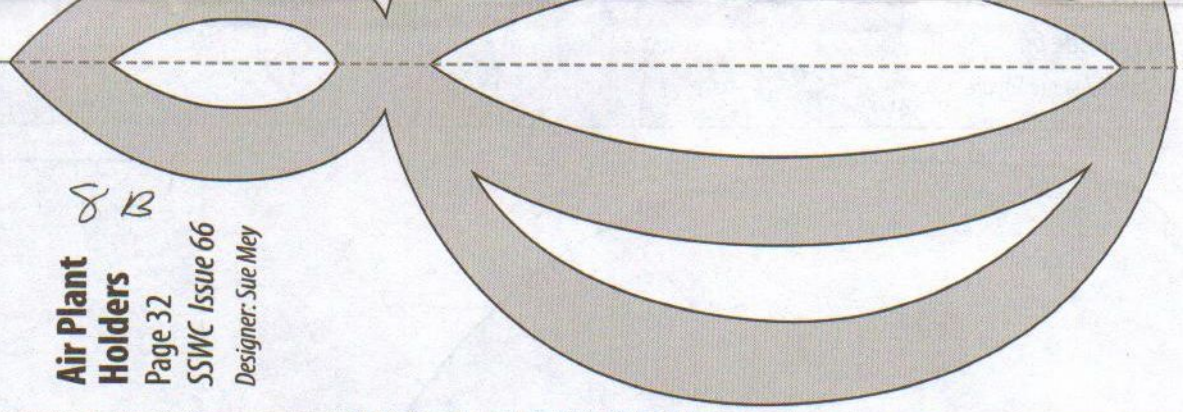

Optional h  
Cut along a

**Fretwork Heart**

Page 31 - SSWC Issue 66

Designer: Sue Mey

